

FULLY OR SEMI MOUNTABLE KERB

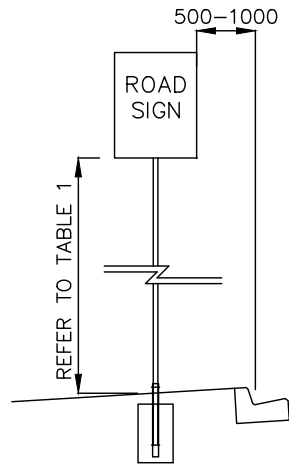

NON MOUNTABLE KERB

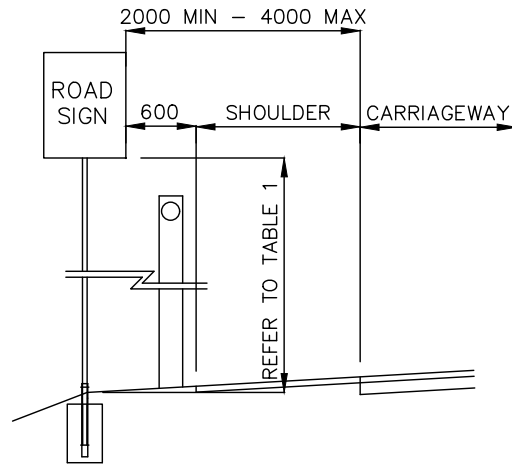

SHOULDER ONLY

NOTES

1. REFER TO MCC 305 FOR SIGNAGE INSTALLATION ON SPLITTER ISLAND.
2. POSTS NOT TO PROTRUDE ABOVE THE TOP OF THE SIGN AND TO HAVE CAPS.
3. ALL SIGNS TO BE INSTALLED AND DESIGNED IN ACCORDANCE TO AS 1742. AND AS 1744.
4. THE MINIMUM PERMISSIBLE VERTICAL HEIGHTS MEASURED FROM THE LOWER EDGE OF THE SIGN OR GROUP OF SIGNS ON THE ONE MOUNTING, TO THE LEVEL OF THE NEAREST EDGE OF THE ROAD TO WHICH THE SIGN APPLIES AS PER TABLE 1.
5. SIGNS TO BE BOLTED AND SECURELY FIXED TO THE POLE
6. POLES TO BE BOLTED AND SECURELY FIXED TO THE SLEEVE.

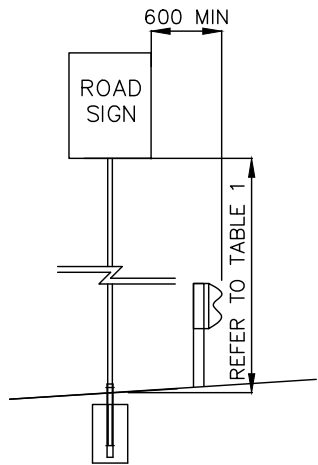

BEHIND GUARD FENCE

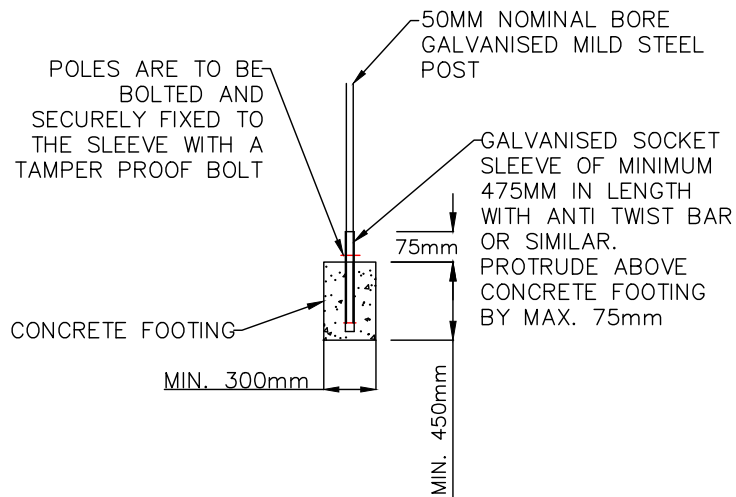

FOOTING DETAIL

SIGNAGE MOUNTING HEIGHT		
A	RURAL ROADS: ALL SIGN EXCEPT AS IN (E)	1.5m
B	URBAN ROADS: KERBSIDE WITH NO PARKING	2.0m
C	URBAN ROADS: KERBSIDE WITH PARKING	2.2m
D	ALL SIGNS ON MEDIANS OR TRAFFIC ISLANDS EXCEPT AS IN (E) AND (F)	1.5m
E	ALL INTERSECTION DIRECTION SIGNS EXCEPT WHERE SIGN OBSTRUCTION PROBLEMS DICTATE SPECIAL MOUNTING HEIGHTS	2m or 2.2m (see(C))
F	HAZARD MARKER SIGNS (EXCEPT WHERE USED AS T-JUNCTION SIGHT BOARDS, SEE (A), (B) OR (C)). KEEP LEFT SIGN ON LOCAL URBAN ROADS	0.5m to 0.7m
G	SIGN MOUNTED ON BREAKAWAY POSTS LARGER THAN 50MM NOMINAL BORE PIPE. HEIGHT ABOVE GROUND LEVEL AT BASE OF POST	2.5m

TABLE 1: MINIMUM MOUNTING HEIGHTS FOR SIDE MOUNTED SIGN

1/4/2024 8:00:44 PM

ISSUE	APPD	DATE	AMENDMENT
E			
D	V.L.	04/24	MINOR MODIFICATION ON TABLE 1
C	M.H.	08/18	ADDED POLES ARE TO BE BOLTED TO SLEEVES
B	M.H.	05/16	REVIEWED AND UPDATED DESIGN
A	V.C.D	01/09	INITIAL DESIGN

GENERAL NOTES

 ENGINEERING SERVICES DEPT

DESIGN	L.SHE
DRAWN	L.SHE
CHECKED	M.HUTCHINSON
DATE	APRIL 2016

PROJECT	STANDARD DRAWING - MCC 205
DETAILS	SIGNAGE OFFSET AND INSTALLATION

N.T.S.	
SHEET 1 OF 1	PAPER A4
DRAWING No.	REV C
FILE NAME MCC 205 - SIGNAGE OFFSET AND INSTALLATION.DWG	