



DALTON
CONSULTING
ENGINEERS

Infrastructure Report Hopkins Road Business Precinct Hopkins Road, Truganina

October 2020
DCE Ref: 20102.2
For

Amended July 2021 to address
the comments of the UDF
consultation process only.

MT. ATKINSON

Disclaimer

Dalton Consulting Engineers Pty Ltd

This report has been prepared solely for the benefit of Mount Atkinson Holdings Pty Ltd and Dalton Consulting Engineers. No liability is accepted by this company or any employee or sub-consultant of this company with respect to its use by any other person.

This disclaimer shall apply notwithstanding that the report may be made available to other persons for an application for permission or approval or to fulfil a legal requirement.

Document History
Revision No:
E
Date:
July 2021
Description:
Infrastructure Report
Prepared:
Rebecca Saber AN: 1481506
Reviewed:
James Cappellari AN: 1241419
Approved:
Theo Liakopoulos AN: 888918

Executive Summary

This infrastructure report outlines the servicing requirements for a proposed circa 47.4 hectare Hopkins Rd Business Precinct development along Hopkins Rd, Truganina, by My Atkinsons Holdings. This Infrastructure Report focuses solely on the Hopkins Rd Business Precinct development and provides a high level servicing strategy for the proposed works. It takes into consideration both the existing and proposed services which will be required to service the site.

The Hopkins Road Business Precinct is strategically located to contribute to the achievement of a greater diversity of employment opportunities in the West Growth Corridor. As noted within the PSP, the Business Precinct will provide opportunities to integrate a mix of higher order services, research and development, and local service businesses in a well-connected network.

As part of the proposed Hopkins Road Business Precinct development, main access will be via Grand Boulevard, Kirkpatrick Boulevard and signalised intersections along Hopkins Rd which are being delivered as part of a staged construction. Grand Boulevard and Kirkpatrick Boulevard will be linked by local connector and access streets. These roads shall be constructed in accordance with the EDCM and Melton City Council design standards

The subject site, situated within the City of Melton, will be developed such that the City of Melton and Melbourne Water stormwater requirements are achieved. Melbourne Water has nominated a connection to the Truganina Development Services Scheme (DSS). Underground drainage at the subject site will be designed to convey minor event flows up to and including the 10% Annual Exceedance Probability (AEP) event. Major flows will be conveyed via the local road network and a proposed grassed swale.

The responsible authority for sewerage facilities is Western Water (WW). Please refer to the sewer concept plan in Figure 14 which highlights the proposed sewer network. The delivery of the Hopkins Rd Outfall Sewer is key to providing a sewer outfall for the proposed Hopkins Road Business Precinct. The proposed gravity sewer network will be extended from the Hopkins Rd Outfall sewer and existing 300mm dia branch sewer along McKinley Rd to service the site.

The responsible authority for water facilities is Western Water (WW). There is an existing 450mm dia. transfer water main on the southern side of Grand Boulevard. It is assumed that several connections will be made to the existing 450mm dia main in order to supply the site. Based on preliminary servicing advice received from Western Water, a proposed 375mm dia. and 300mm dia. water main are to be constructed within the proposed site.

Powercor is the responsible authority for electrical supply to the site. Preliminary information has revealed there are existing underground High Voltage (HV) and Low Voltage (LV) electrical assets within the vicinity of the site. It is assumed that this electrical network will be extended along the local street network in order to service the proposed site. It is assumed that a series of electrical substations will be required within the Hopkins Road Business Precinct to cater for the electrical demand. The number and location of each substation shall be determined during detailed design by a suitably qualified electrical consultant.

The responsible authority for Telecommunication facilities is NBN. Opticomm assets exist along Greigs Rd and Hopkins Rd. It is assumed that these assets will be extended within the site to service the proposed lots.

AusNet is the service provider of gas reticulation services to the site. There is an existing 180mm dia gas main located along Grand Boulevard. It is assumed that this asset will have adequate supply to service the Hopkins Road Business Precinct should it be deemed required.

Contents

Executive Summary	3
1. Introduction	6
2. Precinct Structure Plan (PSP)	8
3. Roads	9
3.1. Grand Boulevard and Kirkpatrick Boulevard	10
3.2. Council Roads	12
4. Storm Water Drainage	14
5. Sewer Reticulation	19
6. Water Reticulation	21
7. Electricity	23
8. Telecommunication Facilities	25
9. Gas Facilities	26
Appendix A – Site Masterplan	28
Appendix B – Gran Boulevard & Kirkpatrick Blvd Design Plans	29
Appendix C – Intersection Plans	30
Appendix D – Stormwater Infrastructure	31
Appendix E – Western Water Servicing Plans	32
Appendix F – Existing Water Main	33
Appendix G – Existing Electrical Assets	34
Appendix H – Existing Telecomm Assets	35
Appendix I – Existing Gas Assets	36
Appendix J – AusNet Transmission Guidelines	37

1. Introduction

The proposed Hopkins Road Business Precinct is approximately 47.4 hectares in total. The development is bound to the north by Grand Boulevard, Hopkins Rd to the east, residential development to the west and undeveloped land to the south. Refer to Appendix A for a Site Masterplan.

This Infrastructure Report focuses solely on the Hopkins Road Business Precinct development, providing a high level servicing strategy. It should be noted that the timing of delivery of the key assets will be driven by the staging of construction works.

It should be noted that there is an existing quarry to the east of the Hopkins Rd and as a result a portion of the site is slightly encumbered by a quarry blast buffer and a quarry sensitive use buffer. These buffers will impact the types of allowable development works on the site.

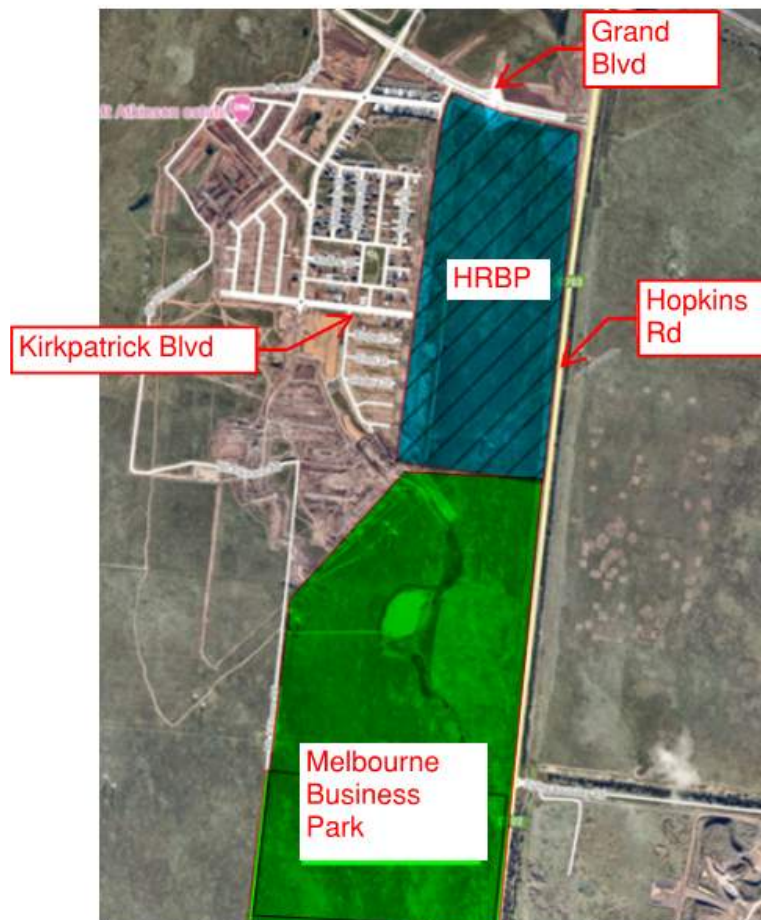

Figure 1: Existing Site Context Plan

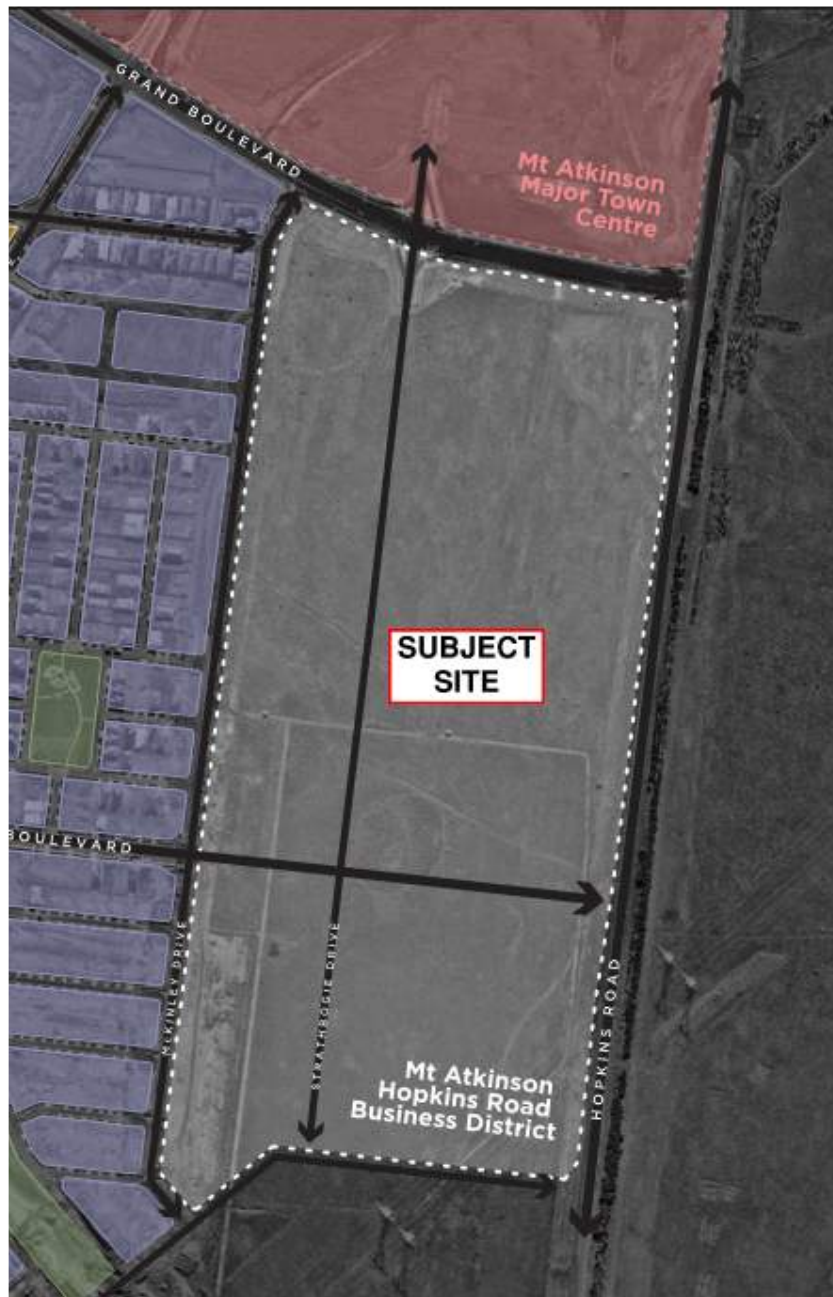

Figure 2: Concept Plan

2. Precinct Structure Plan (PSP)

The site falls under the Mount Atkinson & Tarneit Plains Precinct Structure Plan (PSP) which was amended in January 2020. The amended document has been approved and gazetted by the VPA and Melton City Council

The Hopkins Road Business Precinct is strategically located to contribute to the achievement of a greater diversity of employment opportunities in the West Growth Corridor. As noted within the PSP, the Business Precinct will provide opportunities to integrate a mix of higher order services, research and development, and local service businesses in a well-connected network.

As part of the proposed Hopkins Road Business Precinct, the following key infrastructure works are identified within the PSP. These shall be discussed further throughout this report.

- Delivery of boulevard connector streets, connector streets and local access street in accordance with Melton City Council requirements
- Delivery of Melbourne Water key infrastructure
- Delivery of signalised intersections

3. Roads

As part of the proposed Hopkins Road Business Precinct development, main access will be via Grand Boulevard, Kirkpatrick Boulevard and signalised intersections along Hopkins Rd which are being delivered as part of a staged construction. Grand Boulevard and Kirkpatrick Boulevard will be linked by a local connector and access streets. The first section of Grand Boulevard from Hopkins Rd to Clara Ave is complete with the remainder of the works to commence in the near future.

The construction of Kirkpatrick Boulevard to the west of the subject site is complete. It is assumed as part of the proposed works that the delivery of the remainder of Kirkpatrick Boulevard through the Hopkins Road Business Precinct will be required. This shall also include the delivery of the Kirkpatrick Boulevard/Hopkins Rd Signalised Intersection (IT-04). The signalised intersection IT-04 is a critical access point to the proposed site.

The Mount Atkinson & Tarneit Plains Precinct Structure Plan notes both key road and intersections which are to be delivered as part of the proposed development works. These key items are funded under the PSP. Details of the allocated budget for each item can be found within the Mount Atkinson & Tarneit Plains Infrastructure Contributions Plan (ICP)



Item	Status
IT-03	Works Commenced
RD-05	Construction Complete
IT-08	Construction Complete
RD-04	Construction Complete
IT-04	Works Yet to Commence

Figure 3: Key ICP Works

Please refer to Appendix C for details of Grand Boulevard (RD-05) and Hopkins Rd/Grand Boulevard Intersection (IT-03).

3.1. Grand Boulevard and Kirkpatrick Boulevard

The existing Grand Boulevard is a 4-lane carriageway within a 34m wide road reserve. It will be used as a Principal Public Transport Network (PPTN) road with a shared footpath on each side of the road and on-road bike lanes. Grand Boulevard shall extend from Hopkins Rd through to Troups Rd and beyond.

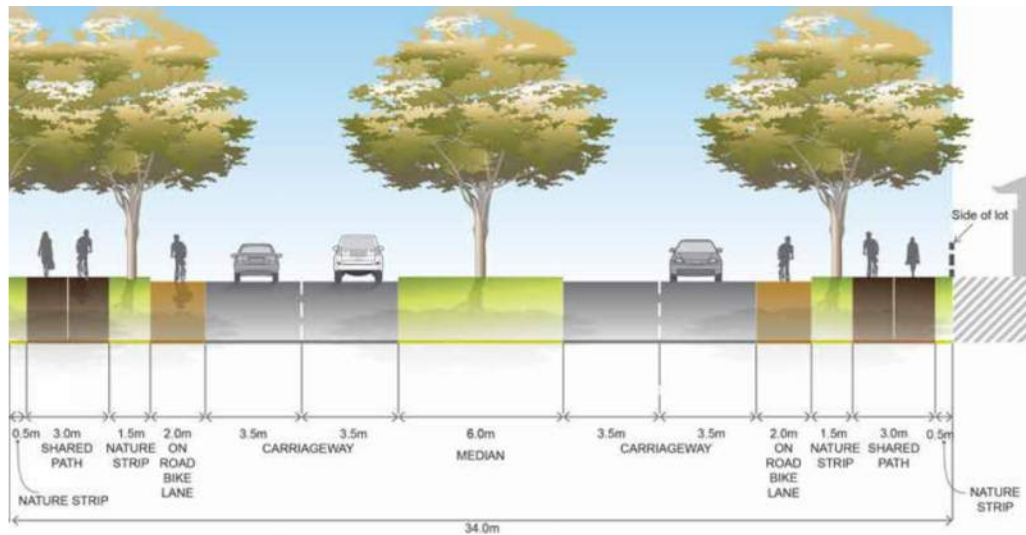

Figure 4: Grand Boulevard Cross Section

The extension of Kirkpatrick Boulevard through the proposed development site will consist of a 31m road reserve. Kirkpatrick Boulevard shall consist of a shared footpath, on road parking bays and off-road bike lanes.

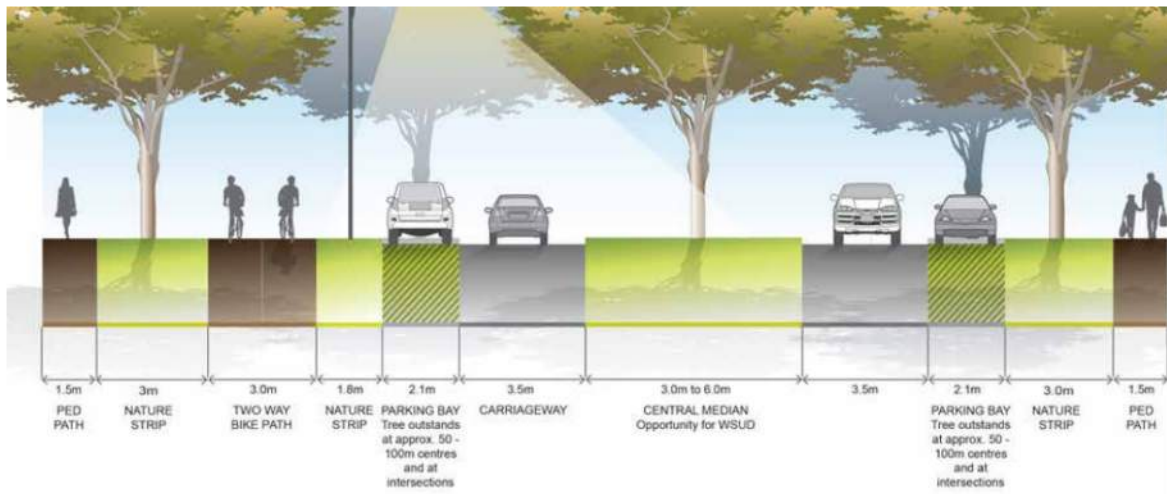

Figure 5: Kirkpatrick Boulevard Cross Section

These boulevards in combination with the completion of the local connector roads surrounding the Hopkins Rd Business Precinct will serve as a key access link. It is assumed that the completion of Kirkpatrick Boulevard and construction of the signalised intersection will require completion prior to compliance being issued on the Hopkins Rd Business Precinct. Further discussions are required with Council.

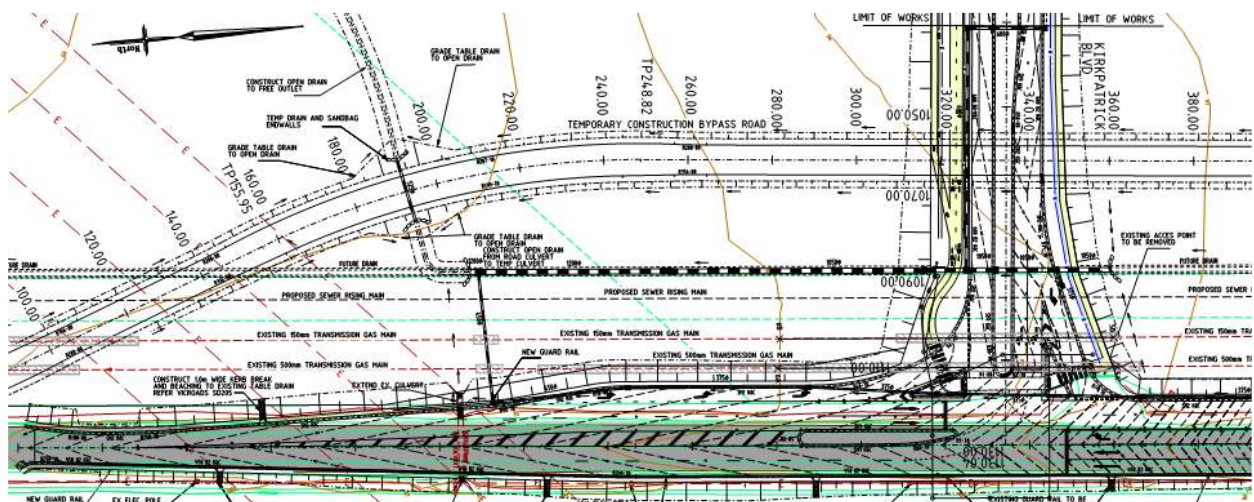

Figure 6: Proposed IT-04 (By Breese Pitt Dixon – Refer to Appendix C)

Providing direct access to properties fronting Grand Boulevard will need to be assessed by a suitably qualified Traffic Consultant.

3.2. Council Roads

The Council roads surrounding and within the Business Precinct site consist of Connector Roads and Access Streets of varying road reserve widths. The proposed McKinley Rd shall be utilised to delineate the proposed business precinct from the existing residential development to the west. Special consideration should be made regarding the proposed landscaping and how to provide an appropriate buffer between these two zones.

These roads shall be constructed in accordance with Melton City Council design standards. Examples of these typical cross sections can be seen below.

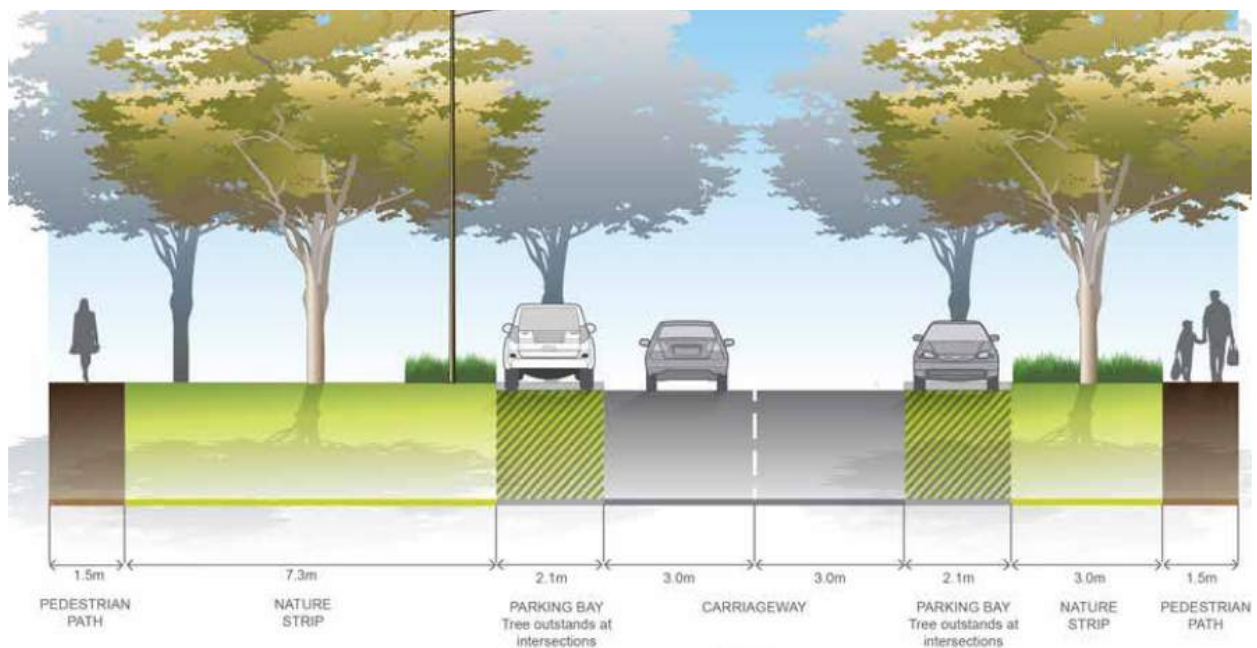

Figure 7: 23m Local Access Street Level 2

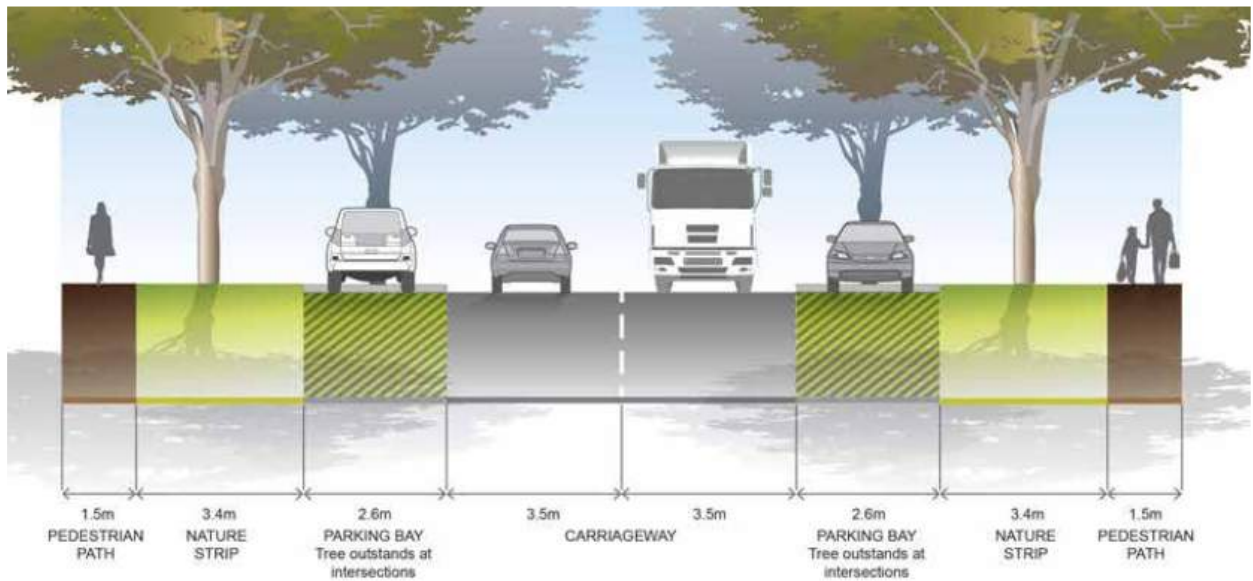

Figure 8: 22m Industrial Access Street

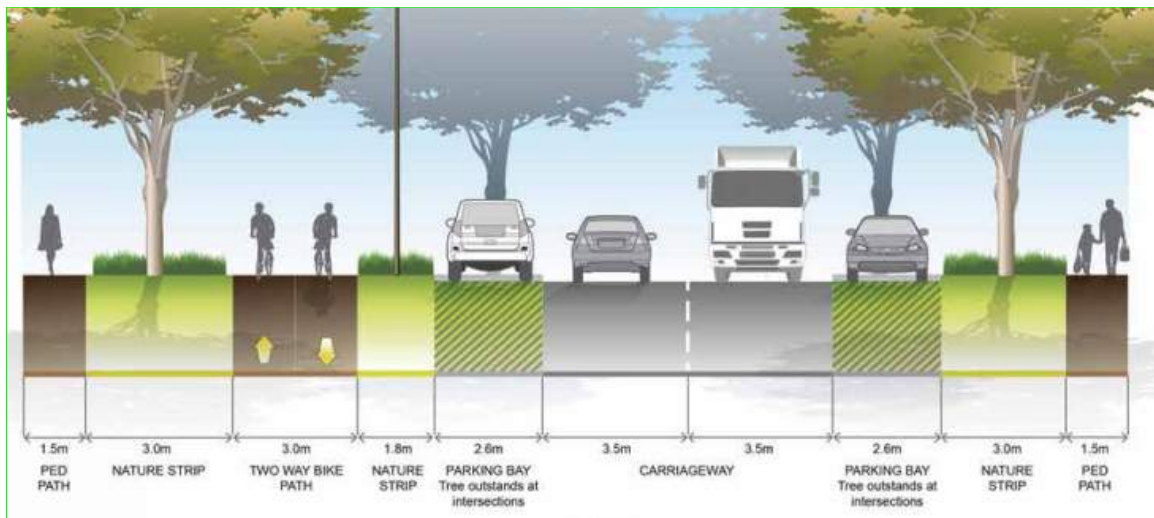

Figure 9: 26m Connector Street

4. Storm Water Drainage

The subject site, situated within the City of Melton, will be developed such that the City of Melton and Melbourne Water stormwater requirements are achieved. Melbourne Water has nominated a connection to the Truganina Development Services Scheme (DSS). Flows from the proposed development will be discharged to the respective DSS via provided scheme drainage outlets at the downstream property boundary.

Underground drainage at the subject site will be designed to convey minor event flows up to and including the 10% Annual Exceedance Probability (AEP) event. In line with the Melbourne Water Scheme, minor flows shall be conveyed towards Nodes A2, A3 and A4 before ultimately discharging into a proposed wetland (WL1ALA). It is expected stormwater quality treatment will be provided by the DSS, and contributions will be paid to the DSS respective of development density, in accordance with Melbourne Water requirements.

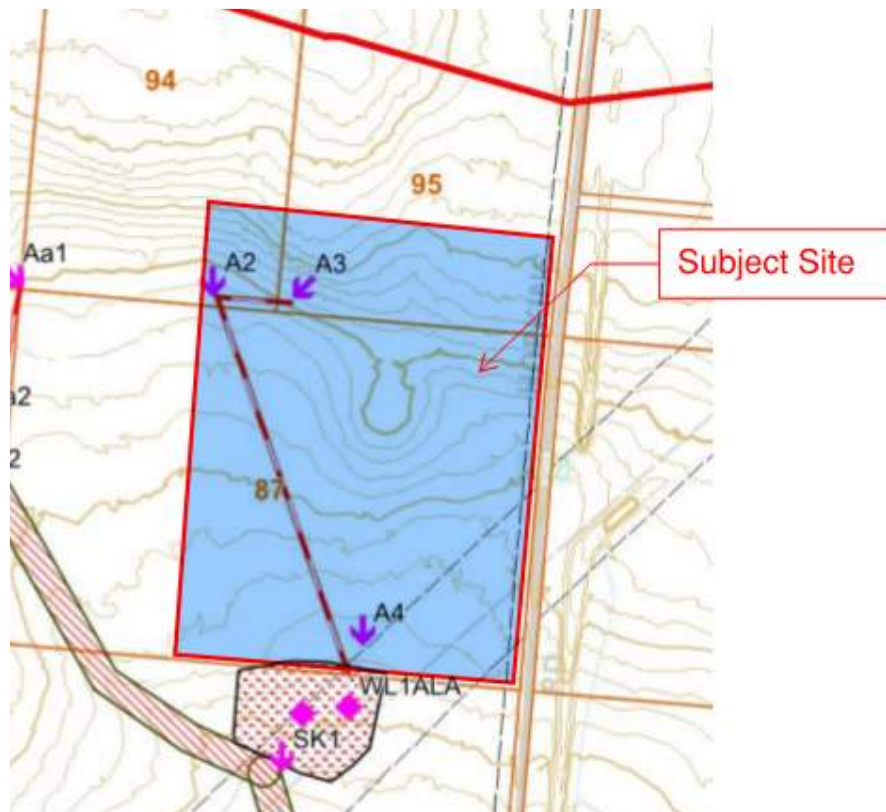
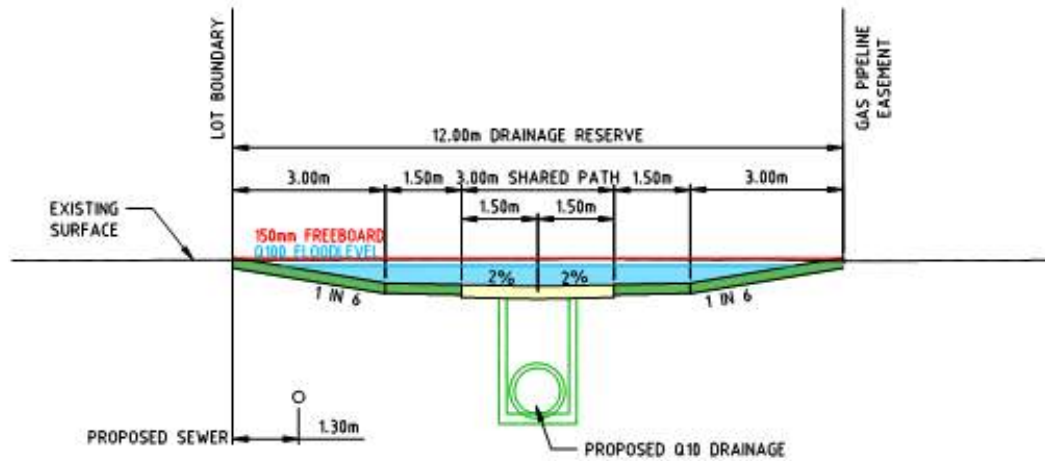

Figure 10: Melbourne Water Scheme Assets

For major events, defined as flows greater than the 10% AEP event and up to and including the 1% AEP event, safe overland flow paths will be provided through the development's internal roads. As noted below in Figure 11, overland flows from Catchment A and B fall towards Hopkins Rd. These overland flows however are required to be directed towards the constructed waterway to the west. In the absence of Council roads along the eastern boundary of the site, it is anticipated that a grassed drainage channel will be required to convey flows. Figure 12 shows preliminary sizing of the proposed channel, this is subject to further refinement during detailed design.



Figure 11: Overland Flow Paths & Catchments Plan



**PROPOSED DRAINAGE RESERVE SECTION
NORTH OF KIRKPATRICK BLVD**

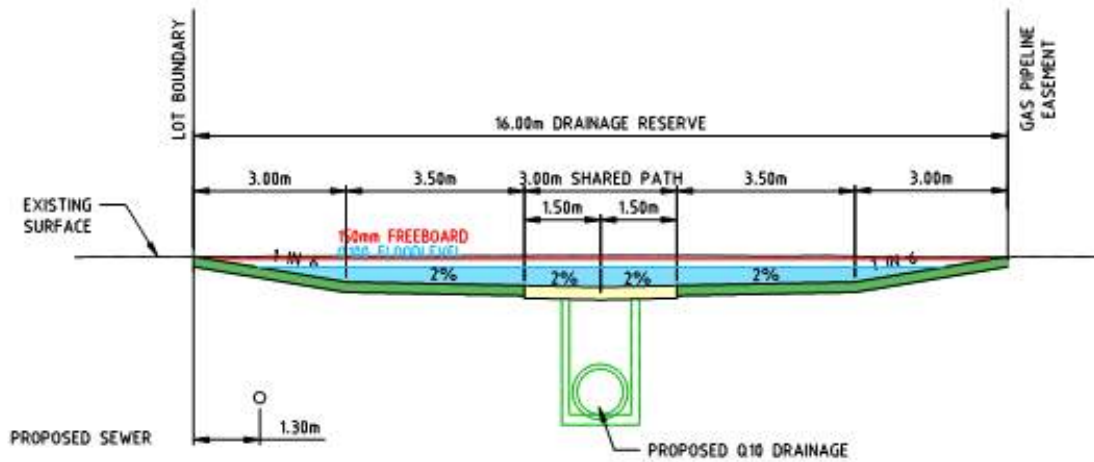

**PROPOSED DRAINAGE RESERVE SECTION
SOUTH OF KIRKPATRICK BLVD**

Figure 12 Proposed Swale Cross Section

It is expected that retention of major flows will be provided by the DSS as such no onsite retention is required. This ensures developed flow do not exceed the pre-developed 1% AEP event flow before discharging to downstream waterways.

In accordance with the Melbourne Water’s scheme plans and preliminary advice the following scheme assets are assumed to be delivered as part of the development works.

Node Ref:	Approx. Size & Length	Ownership/Comments
A3-A2	1200mm dia, 110	Q10 Council Pipeline
A4-A3	1500mm dia, 610m	Q10 Council Pipeline
WL1ALA (WL-12)	NA	MW Asset

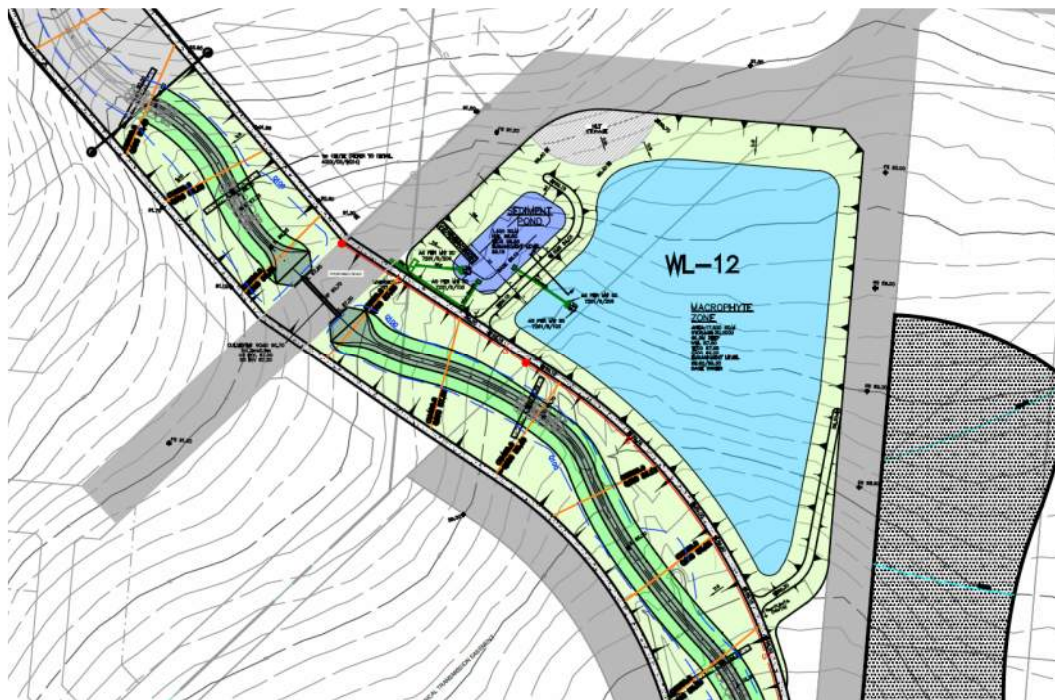

Figure 13: Proposed WL-12 Preliminary Layout (By DPM Consulting Group)

It should be noted that the design and delivery of WL-12 shall be triggered by the development of the residential precinct to the east or the Hopkins Road Business Precinct, which ever proceeds first. It is assumed that the waterway downstream of WL-12 will be delivered as a requirement of the residential development by others.

These assets form part of the ultimate drainage outfall and are considered reimbursable by Melbourne Water. As part of the Truganina DSS the developer will need to enter into an agreement with Melbourne Water to facilitate the payment of drainage contributions. The current rates for each Drainage Scheme based on commercial development are as follows:

- Truganina DSS \$103,431/ha (Hydraulic) and \$84,639/ha (Water Quality).

Melbourne Water have advised that no overarching stormwater management strategy (SWMS) for Mt. Atkinson Estate has been in-principally approved. An approved SWMS exists only for the Mt. Atkinson residential precincts 1 and 2 as well as for Melbourne Business Park. A site-specific storm water management strategy have been prepared by DCE, please refer to the “Hopkins Road Business Precinct Storm Water Management Strategy by DCE, August 2020”.

5. Sewer Reticulation

The responsible authority for sewerage facilities is Western Water (WW).

At the time of this report, there are existing 150mm dia. gravity sewer branches located to the west of the site within the existing local road network surrounding the residential development. In addition to the existing 150mm dia sewer mains, there is a 300mm dia branch sewer in the south west corner of the site along McKinley Drive.

As a requirement of the responsible authority, the minimum sized sewer branch for any commercial development is a 225mm dia branch, as such these existing 150mm dia branches are not deemed suitable for the proposed development works.

Based on preliminary advice from Western Water, the design of the Hopkins Rd Outfall Sewer is well advanced and these works are currently underway. It is assumed that this asset has been sized correctly to cater for the proposed development of the Business Precinct.

Please refer to the sewer concept plan in Figure 14 which highlights the proposed sewer network. As noted below, the delivery of the Hopkins Rd Outfall Sewer is key to providing a sewer outfall for the proposed Hopkins Road Business Precinct. The proposed gravity sewer network will be extended from the Hopkins Rd Outfall sewer and existing 300mm dia branch sewer Along McKinley Rd to service the site. It is not anticipated that any temporary sewer outfall works will be required should the Hopkins Rd Outfall Sewer project proceed.

6. Water Reticulation

The responsible authority for water facilities is Western Water (WW).

There is an existing 450mm dia. transfer water main on the southern side of Grand Boulevard.

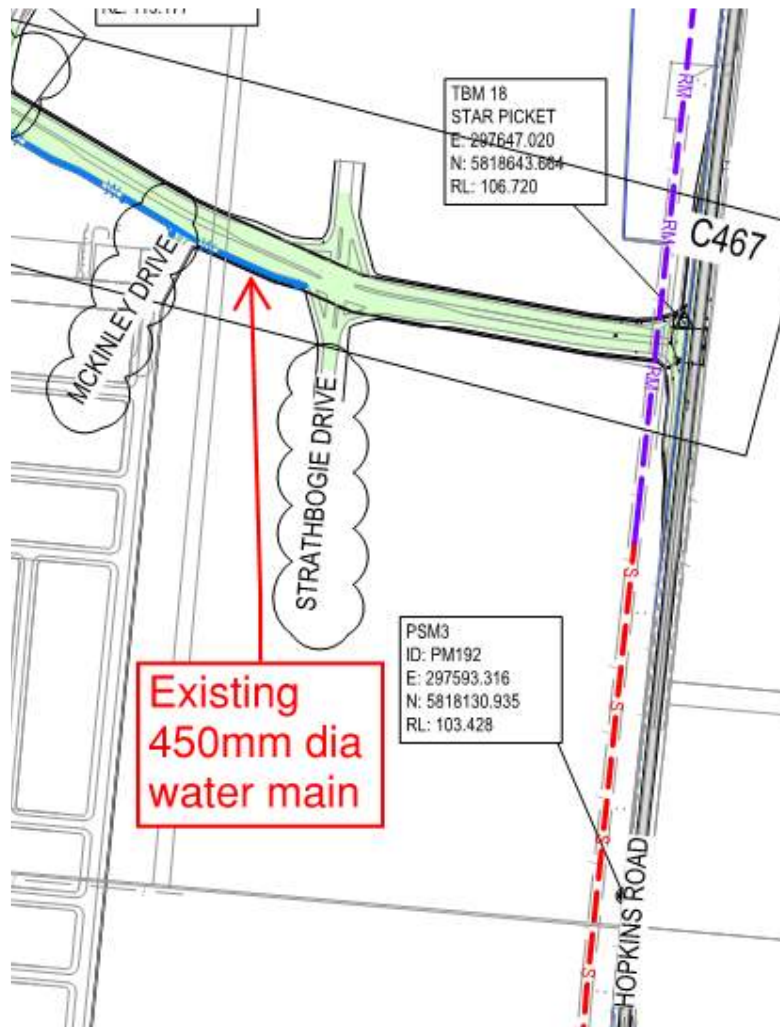

Figure 15: Existing 450mm dia. Water Main

Please refer to Appendix E for construction issue plan of the existing 450mm dia. main.

Based on preliminary servicing advice received from Western Water, a proposed 375mm dia. and 300mm dia. water main are to be constructed within the proposed site. Further discussions with Western Water regarding the final alignment and sizing of these assets are required prior to commencing detailed design works. These trunk assets are considered reimbursable by Western Water.

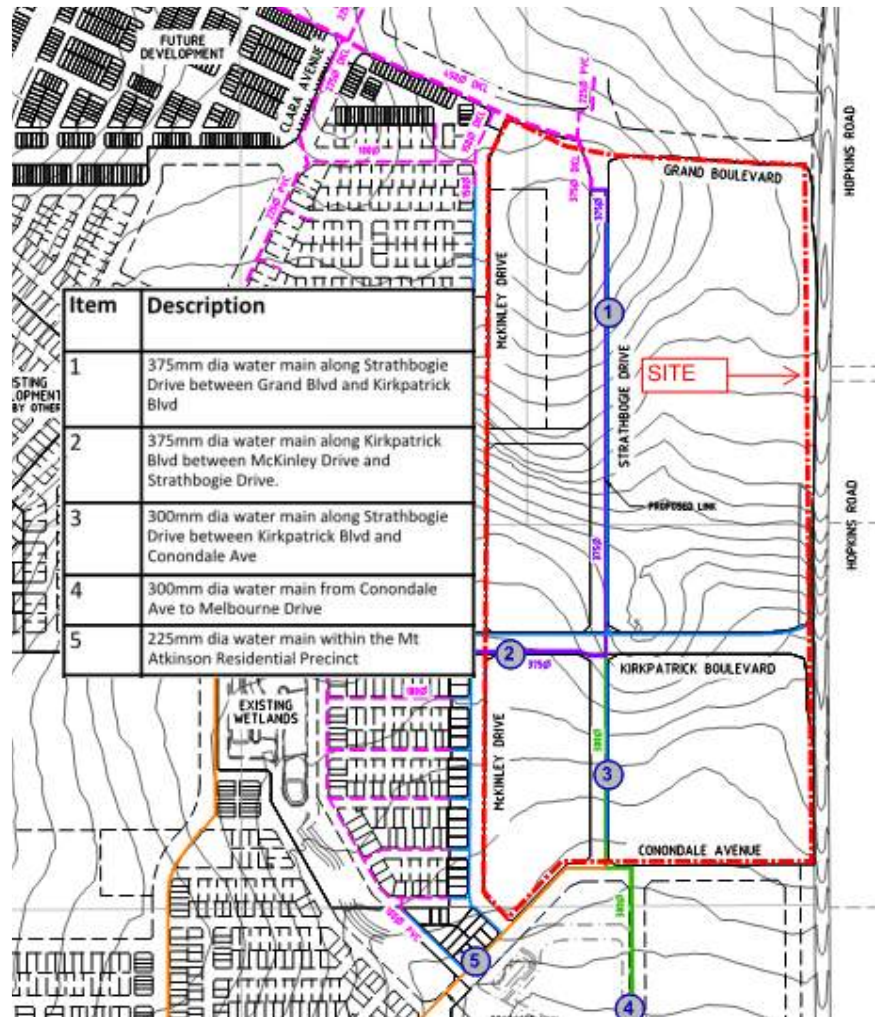

Figure 16: Proposed Water Network

DCE assume that the local road network within the business precinct shall consist of a series of 150mm dia. water mains which will supply the future lots. These mains shall ultimately connect into the existing 450mm dia main as well as the proposed 375mm dia and 300mm dia. mains.

7. Electricity

The responsible authority for Electrical supply facilities is Powercor. A Dial Before You Dig revealed there are existing underground High Voltage (HV) and Low Voltage (LV) electrical assets within the vicinity of the site. It is assumed that this electrical network will be extended along the local street network in order to service the proposed Hopkins Rd Business Precinct.

Based on servicing advice from the electrical consultant Plan B, there is an existing High Voltage 22kV cable in Grand Blvd and also planned along Kirkpatrick Ave. In addition, there is an existing 22kV overhead conductor along Hopkins Rd, to the north of Grand Blvd. This feeder is known as MLN-21 and it is the only feeder currently supplying Mt Atkinson Residential.

There are spare conduits with the developed portions of Mt Atkinson that will form part of the overall supply and network strategy for the site. Please refer to Appendix G for details. A future zone substation is planned to the south of the subject site within the Melbourne Business Park. Timing on the delivery of this asset is currently unknown. Its delivery will be triggered by confirmation of future planned electrical demand load calculations. Based on preliminary discussions with Powercor, overhead power lines are planned along Hopkins Rd. The exact alignment of these assets is yet to be confirmed

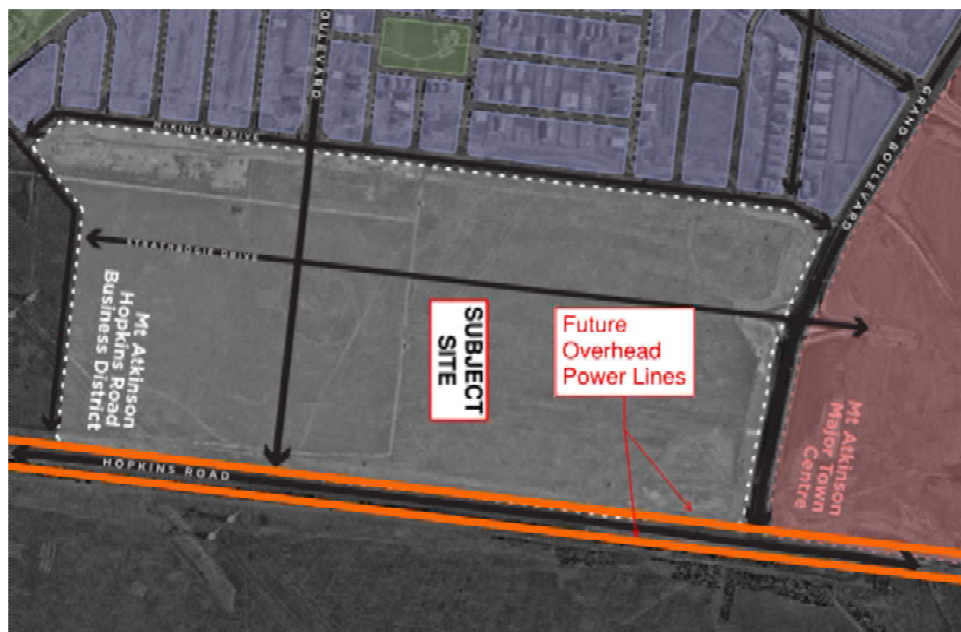

Figure 17a: Proposed Electrical Assets (Refer to Appendix G)

LV power can be found within all the local residential streets which abut the Business Precinct to the west. In addition to the electrical assets along Grand Blvd, Powercor assets exist along Kirkpatrick Blvd and it is assumed that these assets can also be extended within the proposed development site to service the lots.

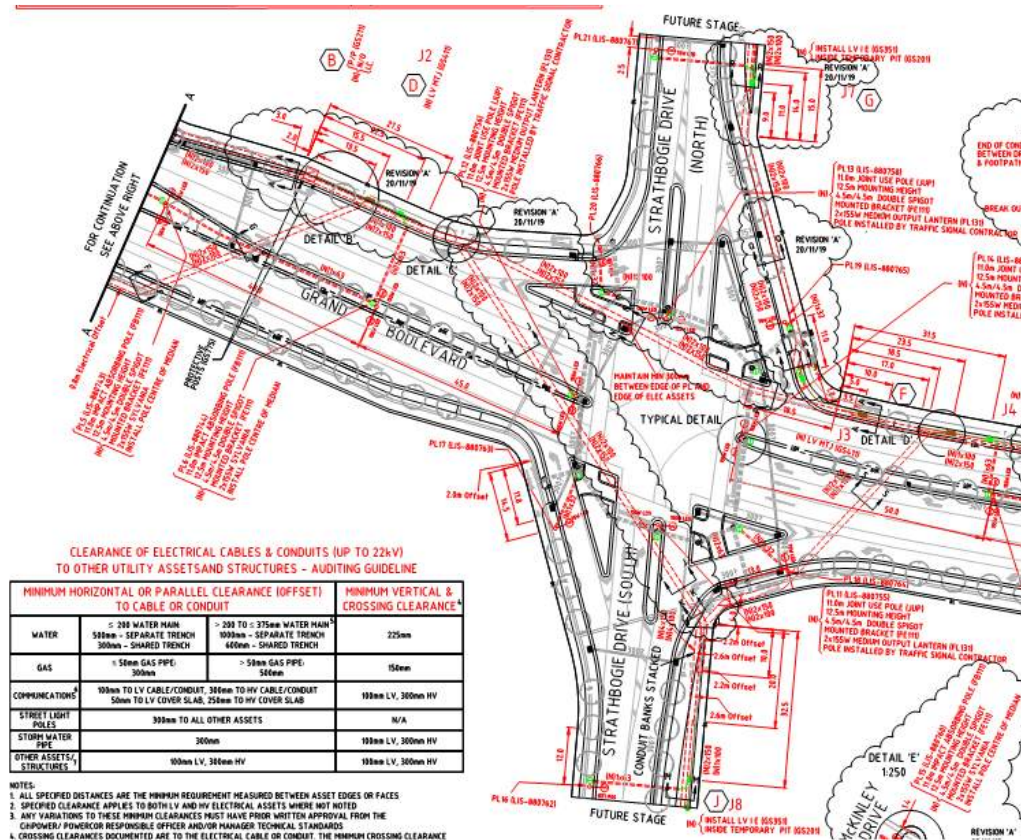

Figure 17b: Strathbogie Dr/Grand Blvd Intersection Electrical Assets (Refer to Appendix G)

In addition to the underground high voltage and low voltage cables, there are existing overhead transmission lines which are owned and managed by AusNet. AusNet have strict design and construction guidelines regarding works in the vicinity of their assets. These guidelines can be found within Appendix J.

All proposed works should be submitted to the AusNet Transmission Group prior to the commencement of works.

8. Telecommunication Facilities

The responsible authority for Telecommunication facilities is NBN

NBN assets exist along the Greigs Rd to the north of development and within Hopkins Rd to the east.

It is assumed that these assets will be extended within the Hopkins Road Business Precinct to service the proposed lots.

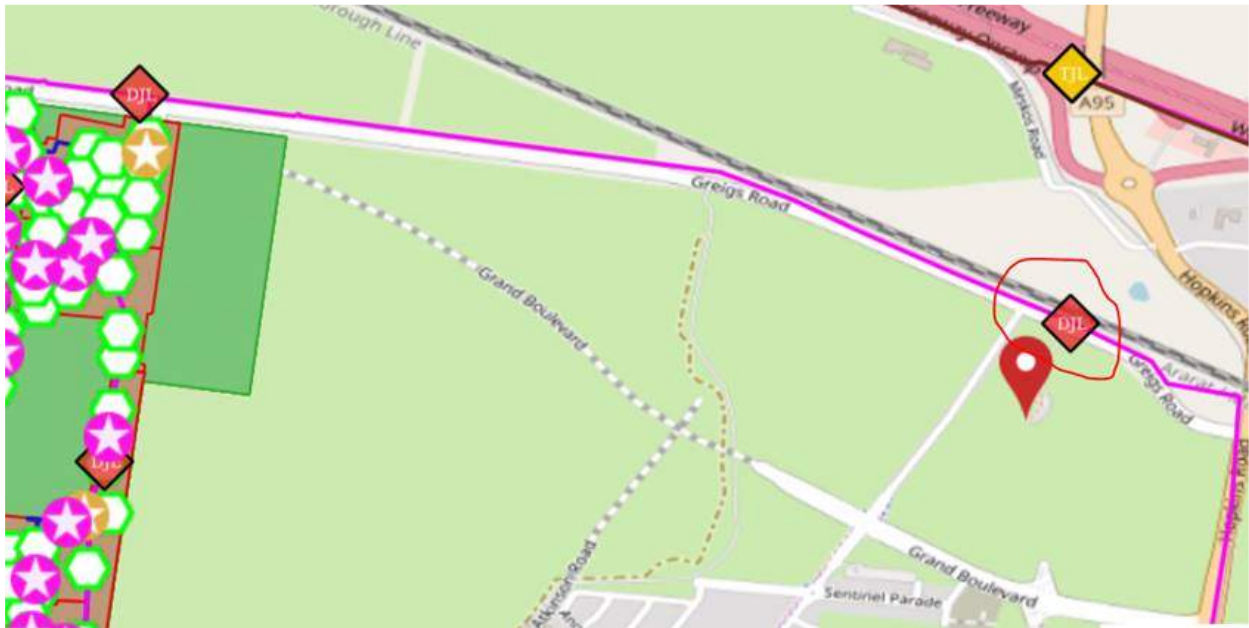

Figure 18: Existing NBN Assets
(refer to Appendix H for further details)

9. Gas Facilities

The responsible authority for gas supply facilities is AusNet.

The provision for gas is not generally considered an essential service for non-residential developments and therefore may not be a mandatory requirement for this development. The provision of services is usually determined by an end user.

There is an existing 180mm dia gas main located along Grand Boulevard and a 120mm dia gas main along Kirkpatrick Blvd. It is assumed that these asset will have adequate supply to service the development should it be deemed required.

Supply can be provided for the development through an application being made directly to AusNet.

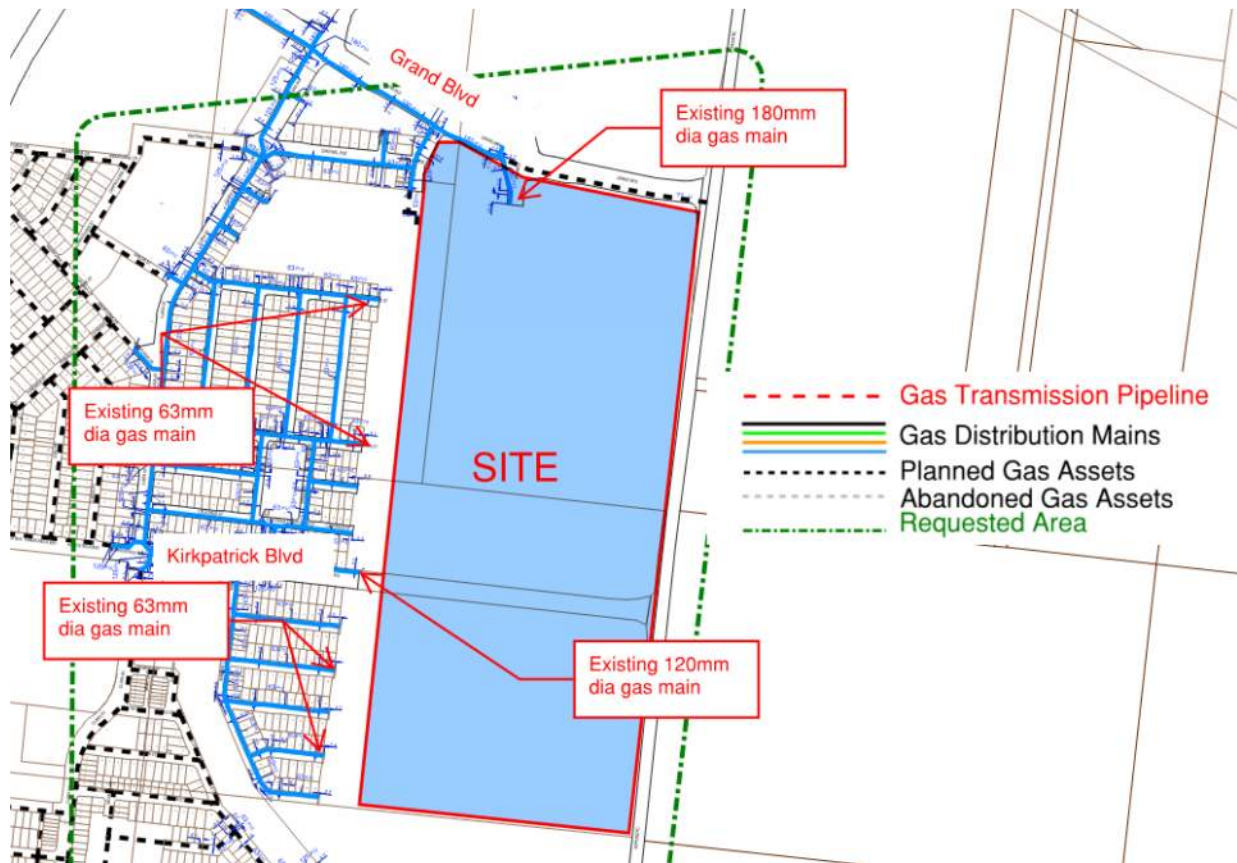

Figure 20: Existing Gas Assets

In addition to the distribution gas main owned and maintained by AusNet Services, APA Group also has assets within the vicinity of the site. There is an existing High-Pressure Gas Transmission line which runs parallel to Hopkins Rd. This asset is contained within a 20m easements.

APA Group must be consulted in the early design phases prior to any works proceeding



Figure 21: Transmission Gas Main

Appendix A – Site Masterplan



Legend

UDF Study Zone 

Other UDF Zone 









Residential 

Local Pocket Park 

School 



Legend

- UDF Study Zone 
- Other UDF Zone 
- Residential 
- Local Pocket Park 
- School 
- Quarry Sensitive Use Buffer 
- Quarry Blast buffer 
- Electrical Easement 

Appendix B – Gran Boulevard & Kirkpatrick Blvd Design Plans

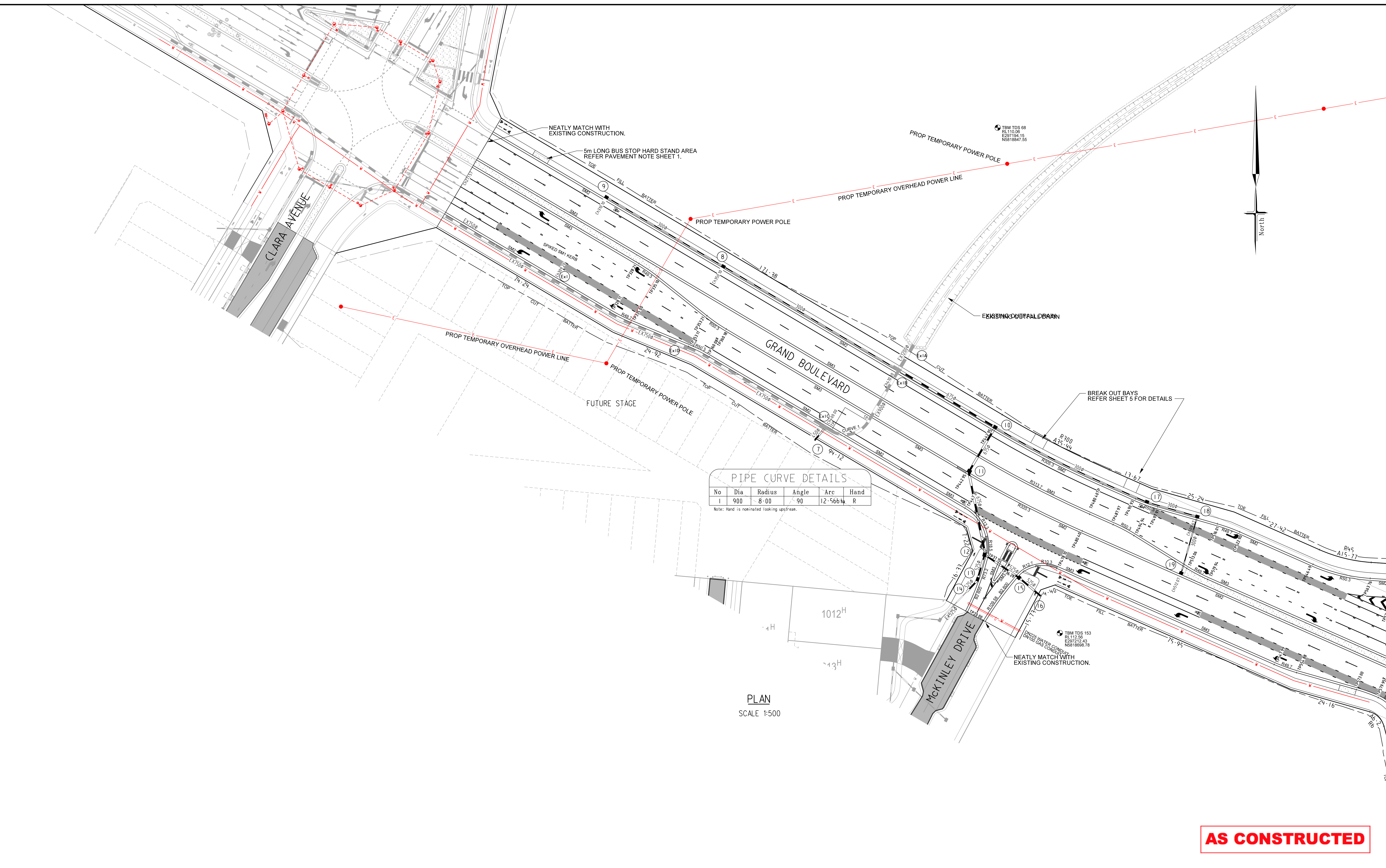

PIPE CURVE DETAILS

No	Dia	Radius	Angle	Arc	Hand
1	900	8.00	90	12.566	R

Note: Hand is nominated looking upstream.

PLAN
SCALE 1:500

AS CONSTRUCTED

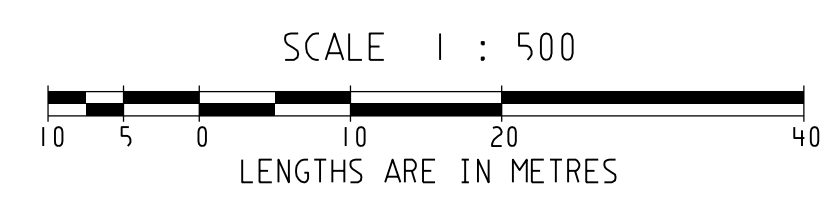

		breese pitt dixon pty. ltd. land surveyors civil engineers		1/19 cato street hawthorn east, 3123 telephone 8823 2300 fax no. 8823 2310	
AMENDMENTS		MELWAY REF. 357-G-4		MUNICIPALITY MELTON	
C 25-11-19 BREAK OUT BAYS ADDED		SURVEY BPD		REFERENCE 8244 E/Grand	
B 17-10-19 NORTHERN PATH OFFSET CHANGED TO 0.05m		DESIGN GJE		SHEET 2 OF 23	
A 18-04-19 ISSUED FOR CONSTRUCTION		DRAWN GJE		DATE APR'19	
VER DATE REMARKS		CHECKED		SCALE AS SHOWN DATUM AHD DATE APR'19	

1:\b2\4\ENG\5\GrandBv.r02.dwg
P:\b2\4\192819

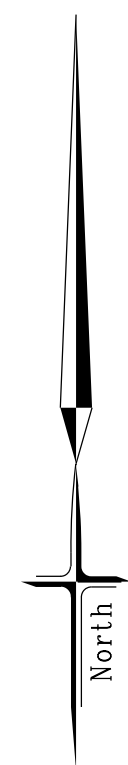
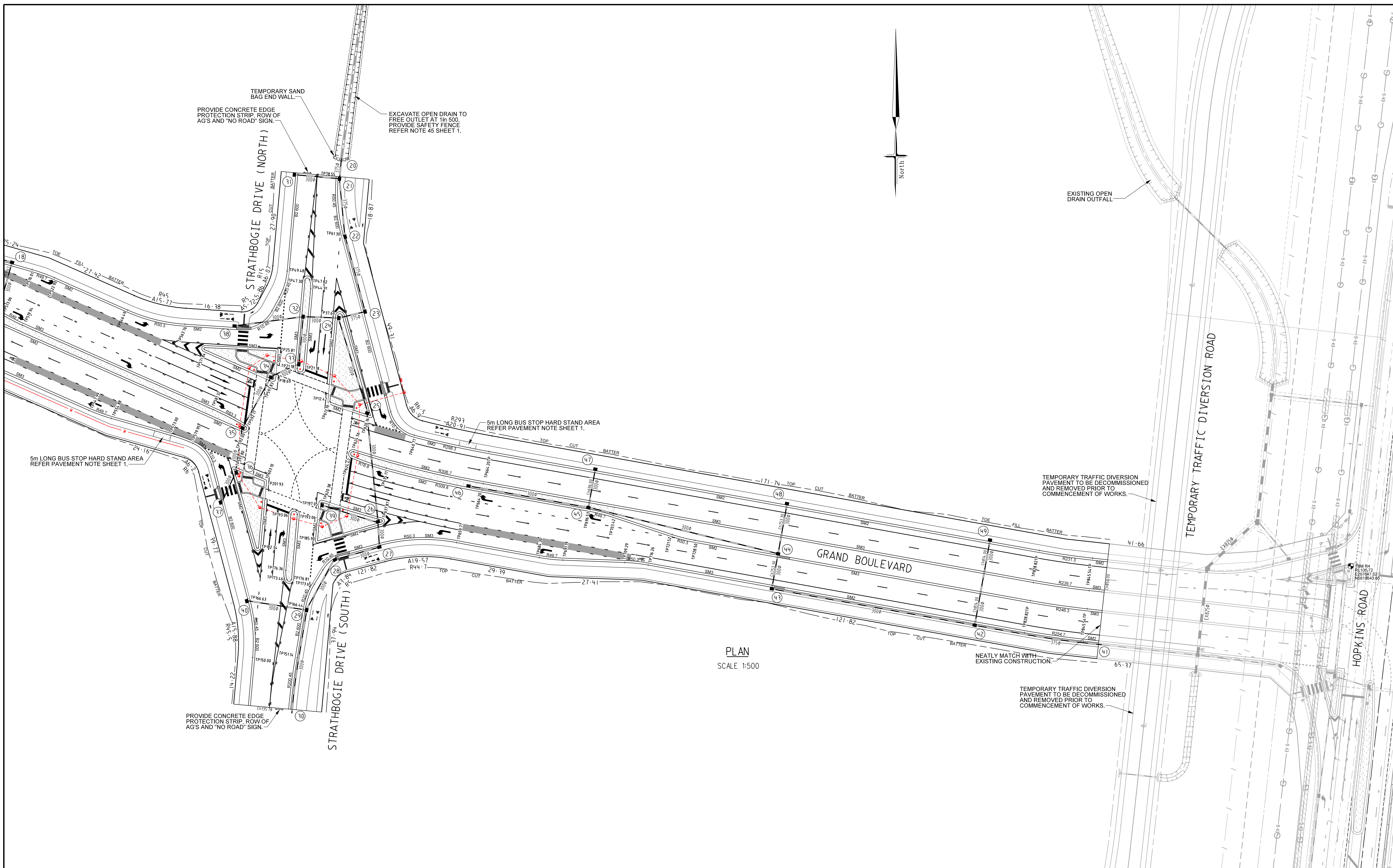

PLAN
SCALE 1:500

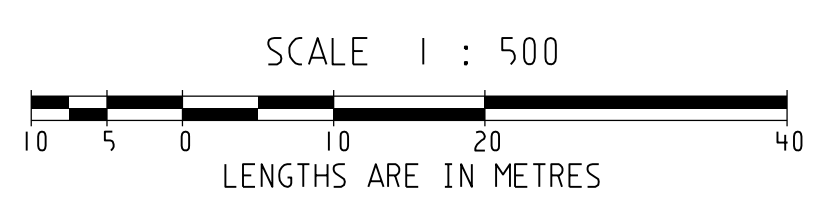

AS CONSTRUCTED

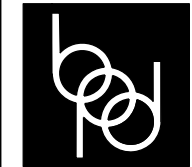
		 breese pitt dixon Pty. Ltd. land surveyors civil engineers		1/19 coto street hawthorn east, 3123 telephone 8823 2300 fax no. 8823 2310	
				MT ATKINSON ESTATE GRAND BOULEVARD HOPKINS RD TO CLARA AVE	
AMENDMENTS		MELWAY REF.	357-G-4	SCALE	AS SHOWN
B	17-10-19	SURVEY	BPD	DATUM	AHD
A	18-04-19	DESIGN	GJE	DATE	APR '19
VER	DATE	REMARKS	DRAWN	GJE	SHEET 3 OF 23
			CHECKED		B

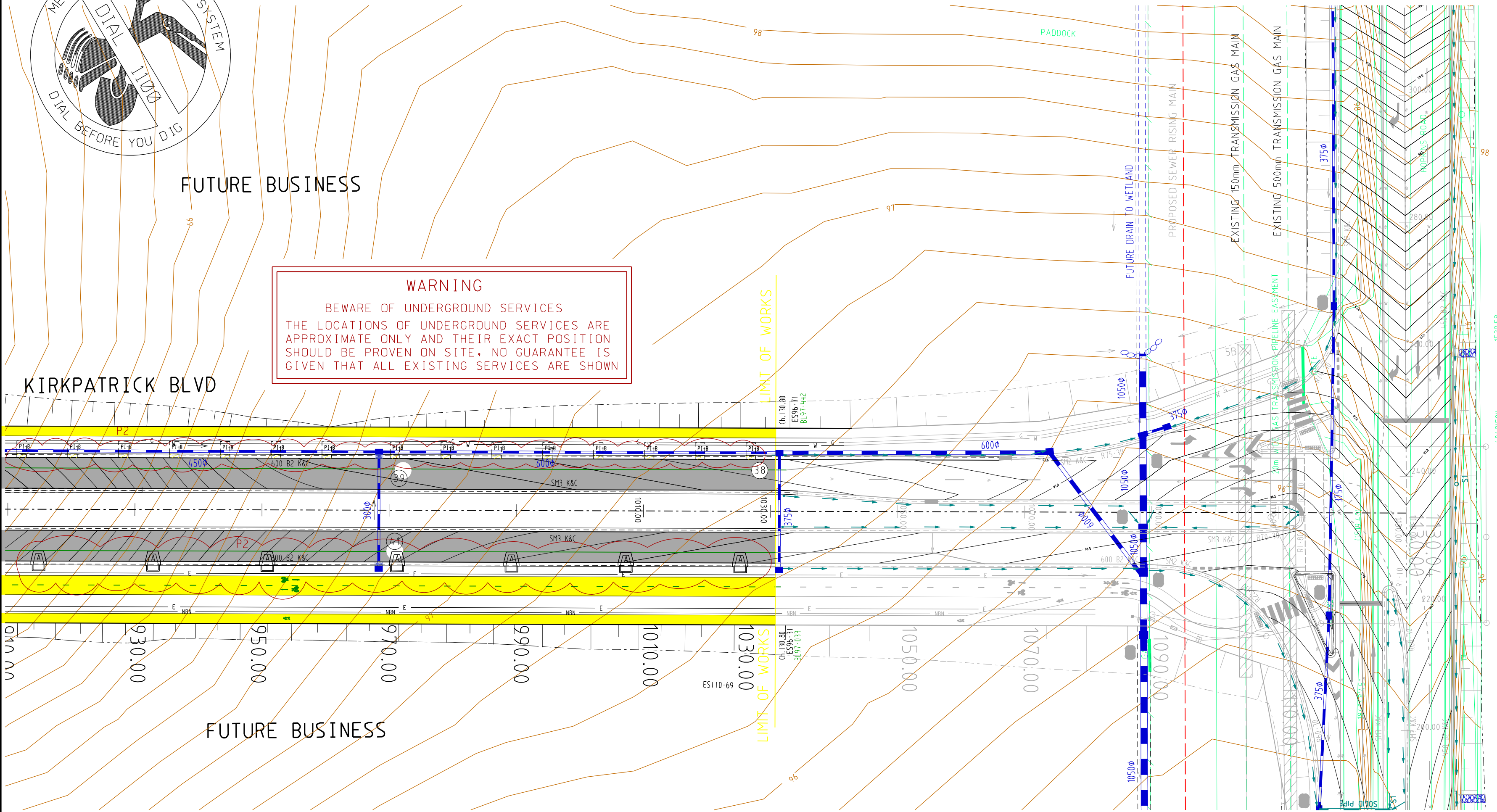
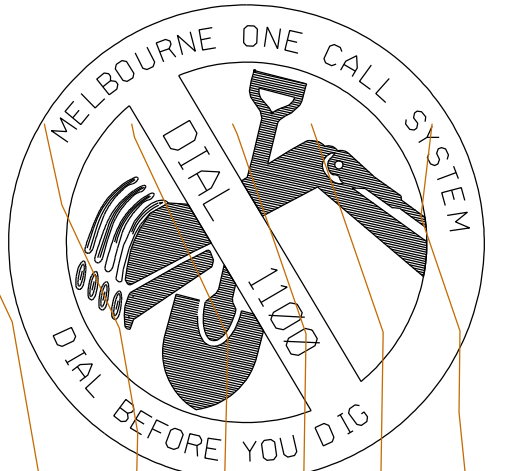
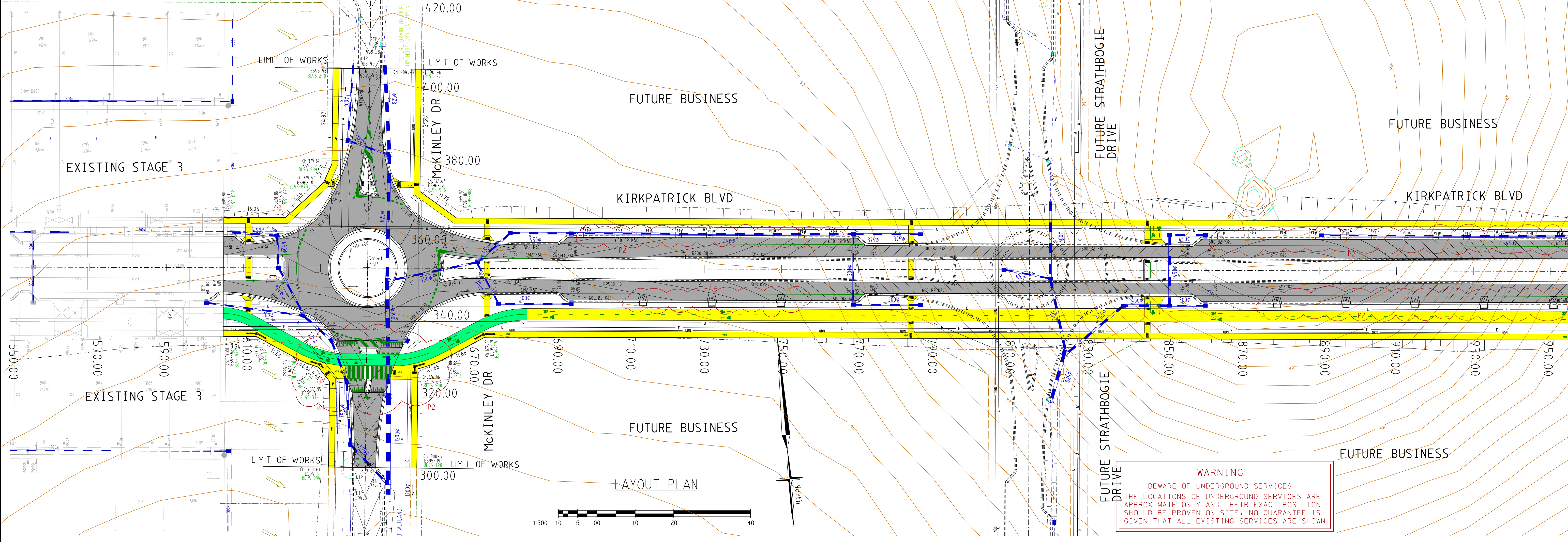

breese pitt dixon pty. ltd.
land surveyors civil engineers

1/19 calo street
hawthorn east, 3123
telephone 8823 2300
fax no. 8823 2310

MELWAY REF. 357-J-6	MT ATKINSON ESTATE KIRKPATRICK BLVD	MUNICIPALITY MELTON
SURVEY B.P.D.	FUNCTIONAL LAYOUT PLAN	REFERENCE 8244 E/KIRK
DESIGN RK	SCALE AS SHOWN DATUM AHD	SHEET 1 OF 4 P2
DRAWN RK	DATE APR. 20	
CHECKED		

VER.	DATE	REMARKS

Appendix C – Intersection Plans

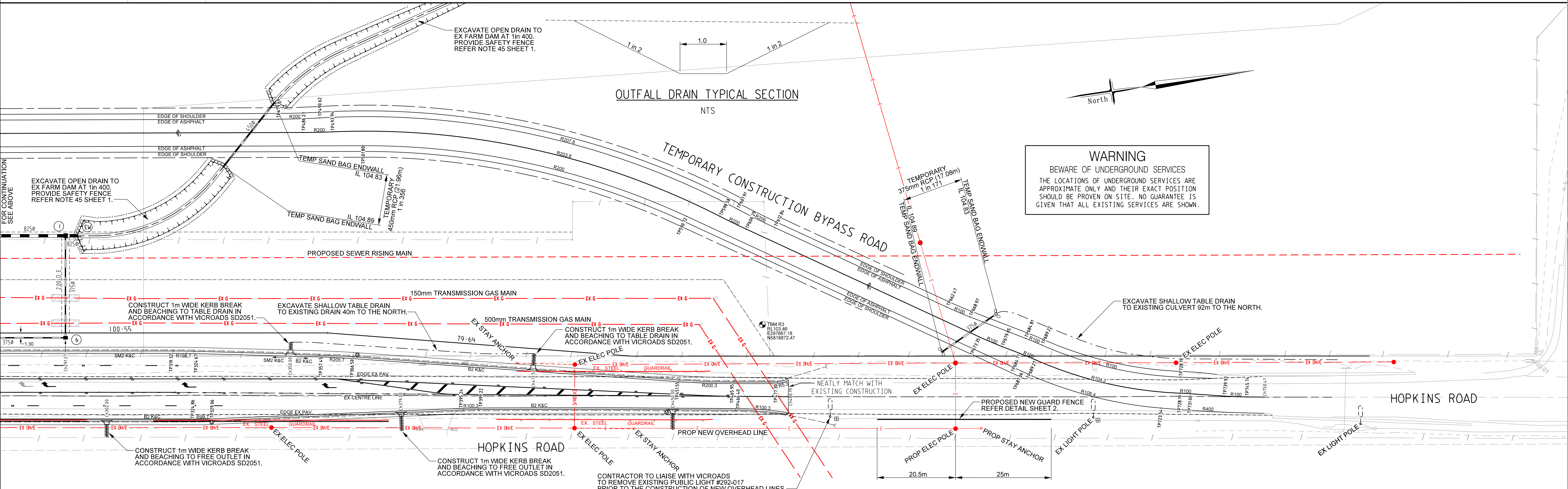
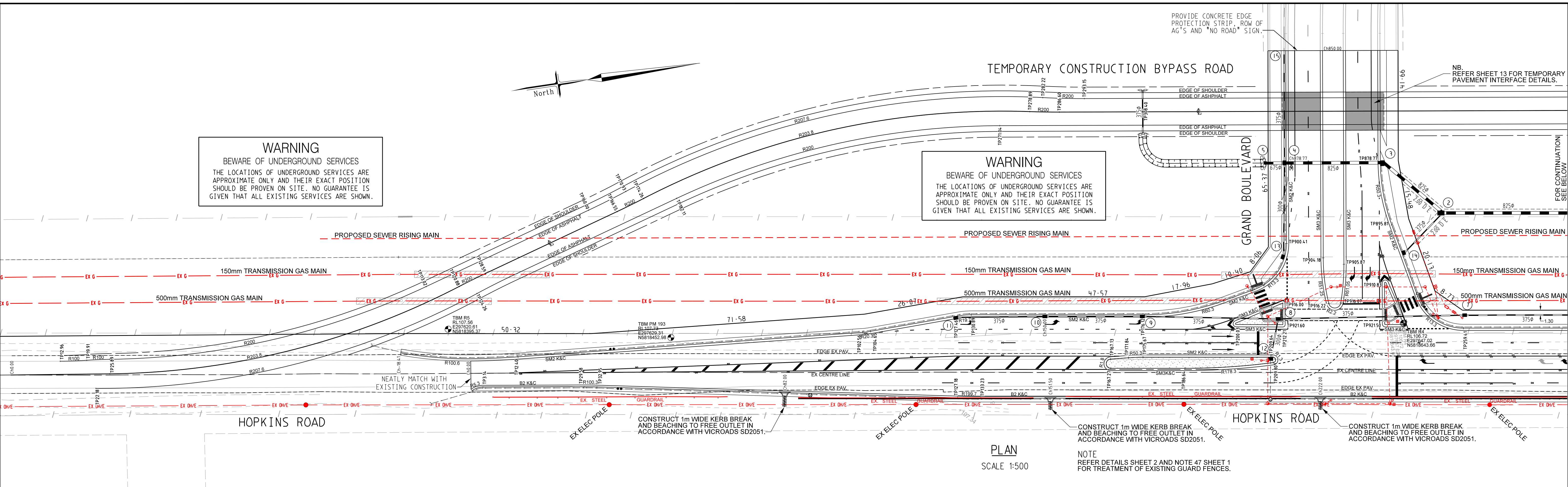

AMENDMENTS		MELWAY REF. 357-G-4	breese pitt dixon pty. ltd. land surveyors civil engineers		1/19 cato street hawthorn east, 3123 telephone 8823 2300 fax no. 8823 2310
C	11-10-19	GRAND NORTHERN PATH MOVED TO AN 0.05m OFFSET	SURVEY	BPD	MUNICIPALITY MELTON
B	23-08-19	BYPASS ROAD REGRADED & CULVERT ADDED	DESIGN	GJE	REFERENCE 8244 E/Int1
A	18-04-19	ISSUED FOR CONSTRUCTION	DRAWN	GJE	SHEET 3 OF 17
VER	DATE	REMARKS	CHECKED	SCALE AS SHOWN	DATUM AHD
				DATE APRIL '19	

WARNING
BEWARE OF UNDERGROUND SERVICES
THE LOCATIONS OF UNDERGROUND SERVICES ARE APPROXIMATE ONLY AND THEIR EXACT POSITION SHOULD BE PROVEN ON SITE, NO GUARANTEE IS GIVEN THAT ALL EXISTING SERVICES ARE SHOWN

WARNING EXISTING OVERHEAD CABLES REFER AUSNET DRAWING NUMBER VE5/75030056/1 FOR DETAILS OF CLEARANCE OF NEW ROAD

WARNING
BEWARE OF UNDERGROUND SERVICES
THE LOCATIONS OF UNDERGROUND SERVICES ARE APPROXIMATE ONLY AND THEIR EXACT POSITION SHOULD BE PROVEN ON SITE, NO GUARANTEE IS GIVEN THAT ALL EXISTING SERVICES ARE SHOWN

ATTENTION TO CONTRACTOR
1. IT IS THE CONTRACTORS RESPONSIBILITY TO ENSURE THAT THE DIGITAL PLAN, PROVIDED FOR SETOUT PURPOSES, MATCHES THE T.B.M. COORDINATES SHOWN.
2. WHERE CONCRETE WORKS ABOUT A SEWER ACCESS CHAMBER SURROUND OR SIMILAR STRUCTURE, AN EXPANSION JOINT OF APPROVED MATERIAL SHALL BE PROVIDED BETWEEN THE TWO FACES.

ATTENTION TO CONTRACTOR
ALL DISTURBED ROAD VERGES AS A RESULT OF CONSTRUCTION SHALL BE REINSTATED TO THE SATISFACTION OF THE RESPONSIBLE AUTHORITY

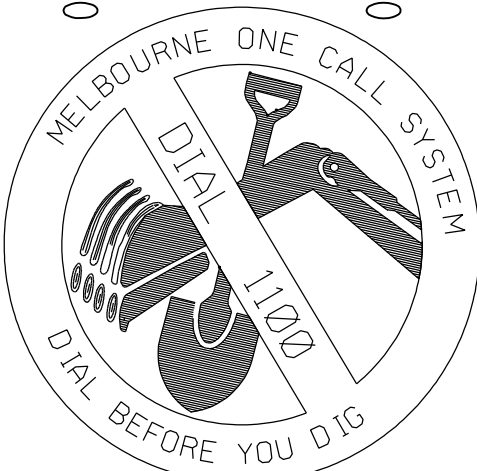
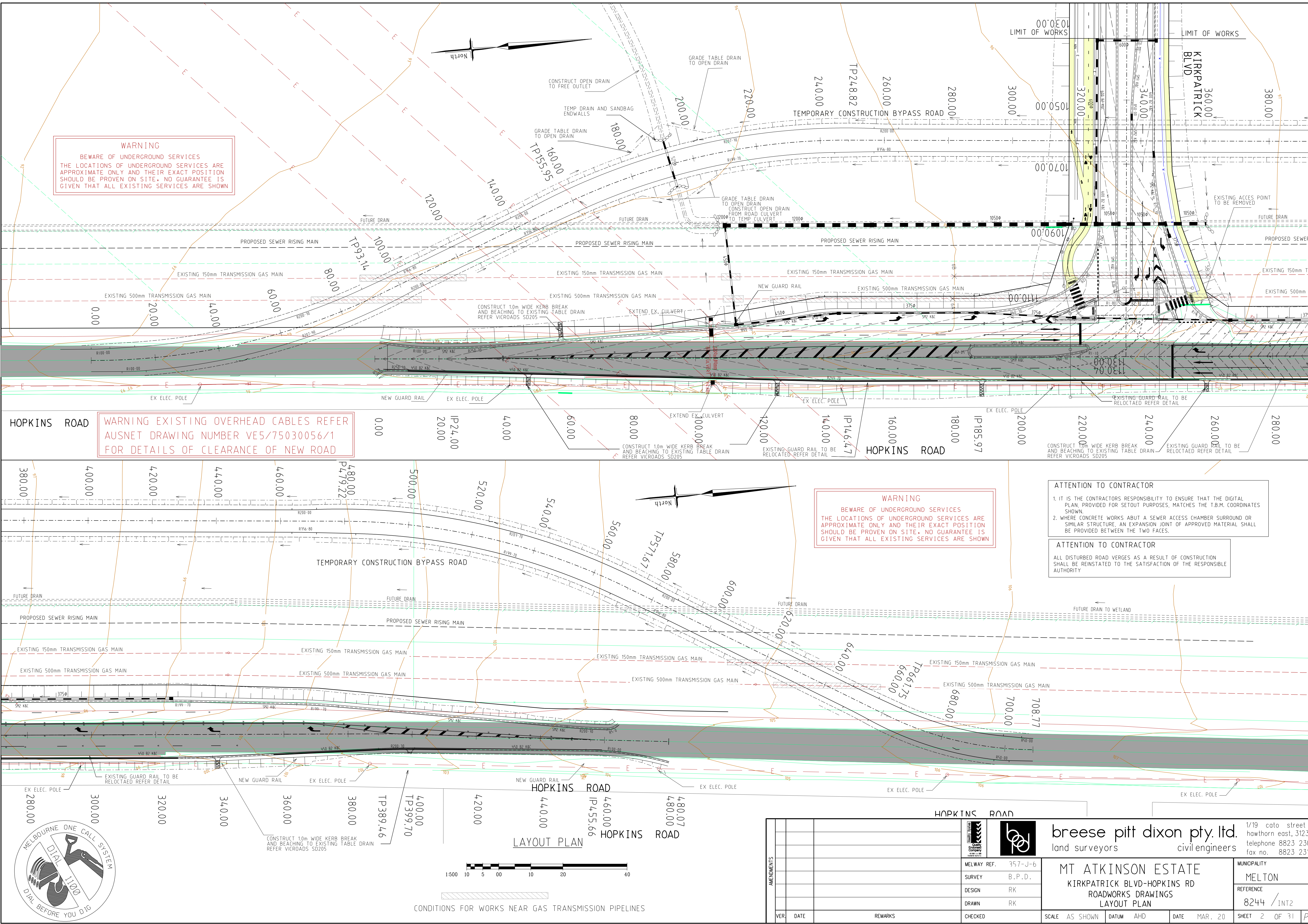

CONDITIONS FOR WORKS NEAR GAS TRANSMISSION PIPELINES

AMENDMENTS	VER.	DATE	REMARKS

breese pitt dixon pty. ltd.
land surveyors civil engineers

1/19 coto street
hawthorn east, 3123
telephone 8823 2300
fax no. 8823 2310

MT ATKINSON ESTATE
KIRKPATRICK BLVD-HOPKINS RD
ROADWORKS DRAWINGS
LAYOUT PLAN

MUNICIPALITY
MELTON

REFERENCE
8244 /INT2

SCALE AS SHOWN DATUM AHD DATE MAR. 20 SHEET 2 OF 31 P2

Appendix D – Stormwater Infrastructure

LEGEND

- EX. DRAIN
- PROPOSED SCHEME DRAIN - DEANSIDE DRIVE DS 4169
- PROPOSED SCHEME DRAIN - NEALE ROAD DS 4144
- PROPOSED SCHEME DRAIN - TRUGANNA DS 4068

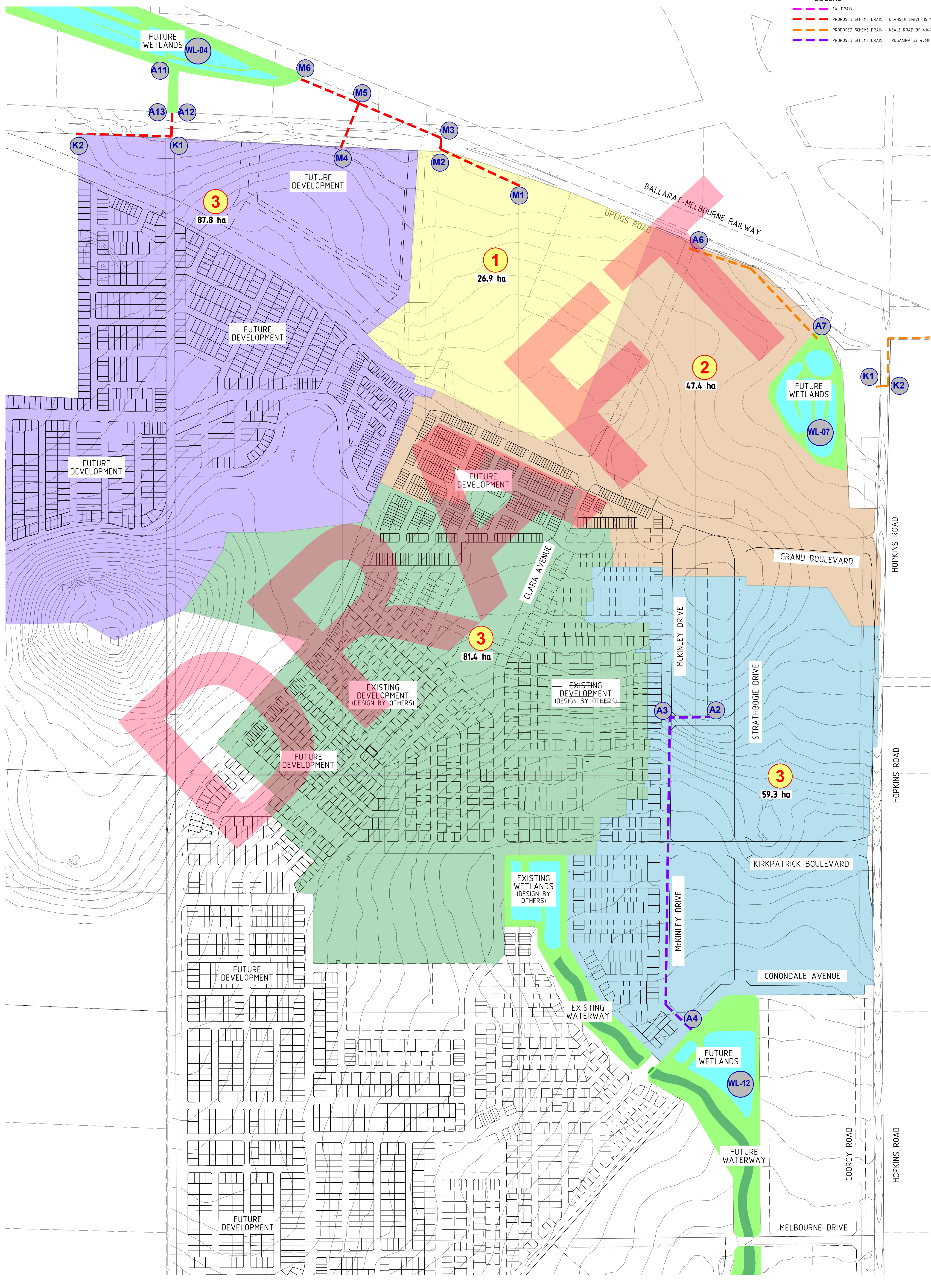

**MT ATKINSON
DRAINAGE MASTER PLAN**

DCE REF 20102MP04 (DRAINAGE)
 DRAWN BY R.SABER
 REVISION A
 REV DATE 12/05/2020

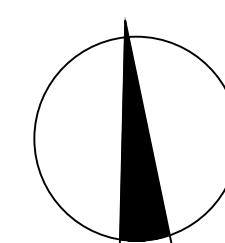
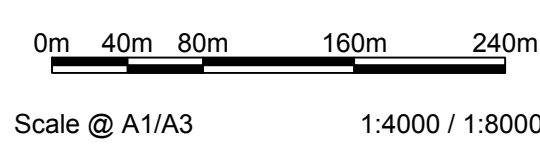

DALTON CONSULTING ENGINEERS
 ABN 78 429 221 049
 VICTORIA T 61 3 9813 7400 W dceng.com.au
 QUEENSLAND T 61 7 3374 9000 E info@dceng.com.au

FOR DISCUSSION

Drawing File: C:\128_Synergy\delta\delta\ENERGY-MEL\20102-M Atkinson_1942\1_DESIGN\01_LAYOUT\03_GENERAL\MASTER PLANS\20102MP04 (Drainage).dwg - 20102MP04 (DRAINAGE)
 Date/Time: Fri May 15, 2020 - 11:41am
 User: r.saber

DSCM Legend

	DSS Boundary
	DS Strategy Boundary
	DSCM Property Stage (Allocated)
	Stage (Works in Progress)
	Stage (Finalised)
	Node
	Bio-Retention Swale

	Channel
	Cleanout works
	Culvert
	Grassed Swale
	Low flow pipe with Channel
	Overland flow path
	Pipeline
	Soft Engineering

	Bio-Retention Basin
	Buffer Strip
	Inlet/Outlet Structure
	Junction Pit
	Litter trap
	Retarding Basin
	Sediment trap
	Wetland

As Constructed Legend

	Channel
	Natural Waterway
	Sewer Main
	Underground Drain
	Water Main

	Flood Extents
	Lake
	Retarding Basin
	Sediment Trap
	Wetland

Plan Date: April 2017
Melbourne Water is providing this information as a guide only. It is not intended as a basis for future design and works. The appropriate engineering professional will perform the design and construction of any infrastructure for this project. Please note that any infrastructure designed and constructed by Melbourne Water will be subject to the approval of the relevant regulatory authorities. The serviceability of any infrastructure provided as part of this project is the responsibility of the contractor. Melbourne Water will not be liable for any damage, injury or loss of property or special loss or damage, arising from any use, error, omission, incompleteness or other defect in this plan.
Copyright Melway Publishing 2010
Reproduced from Melway Edition 37 with permission.

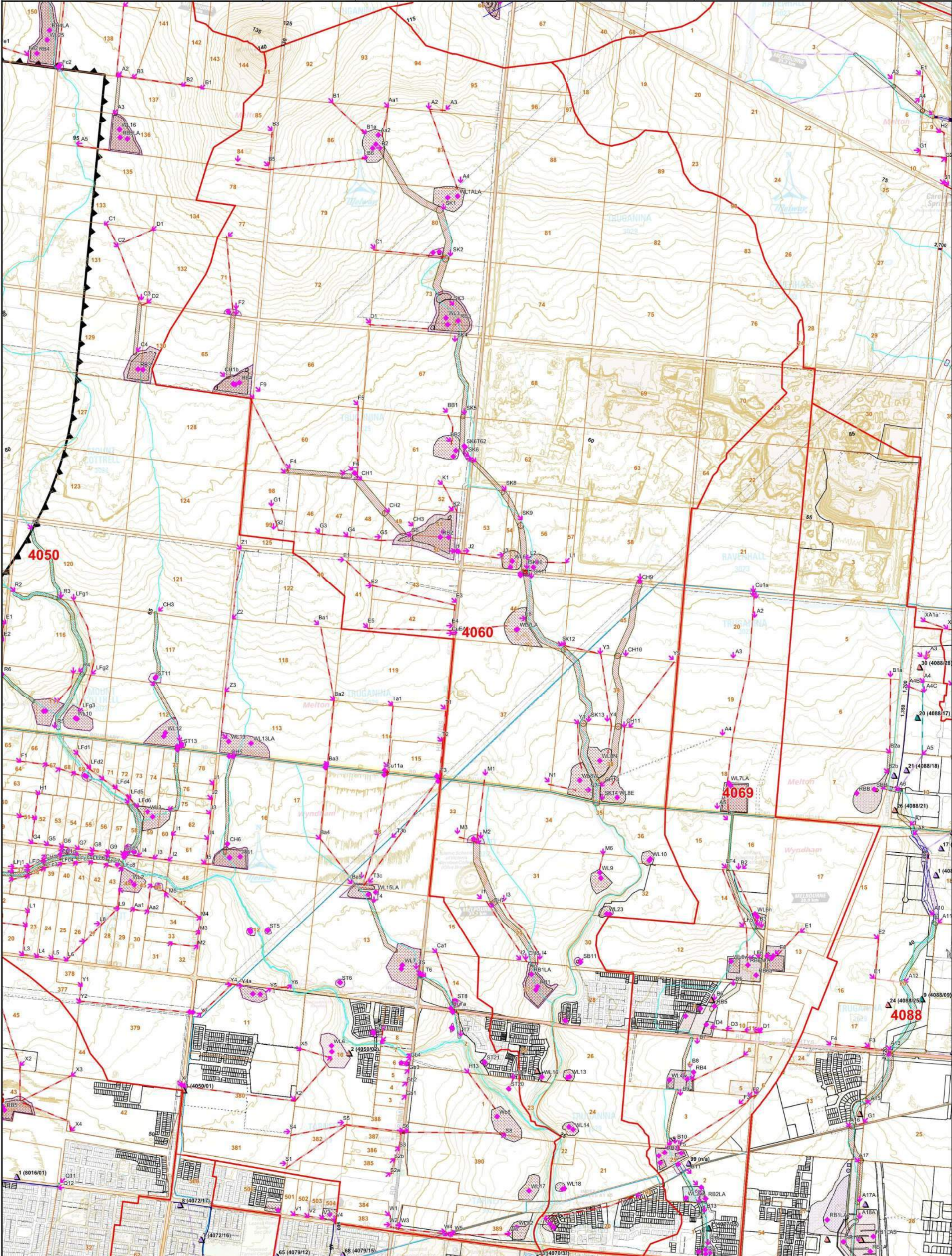

PROJECT: 20102.1 LFR Drainage Reserve

South of Kirkpatrick

Print-out date: 28/05/2020 - Time: 14:09

Data File: C:\Users\rebecca.saber...\20102.1 LFR drainage reserve (South of Kirkpatrick).dat

1. CROSS-SECTION:

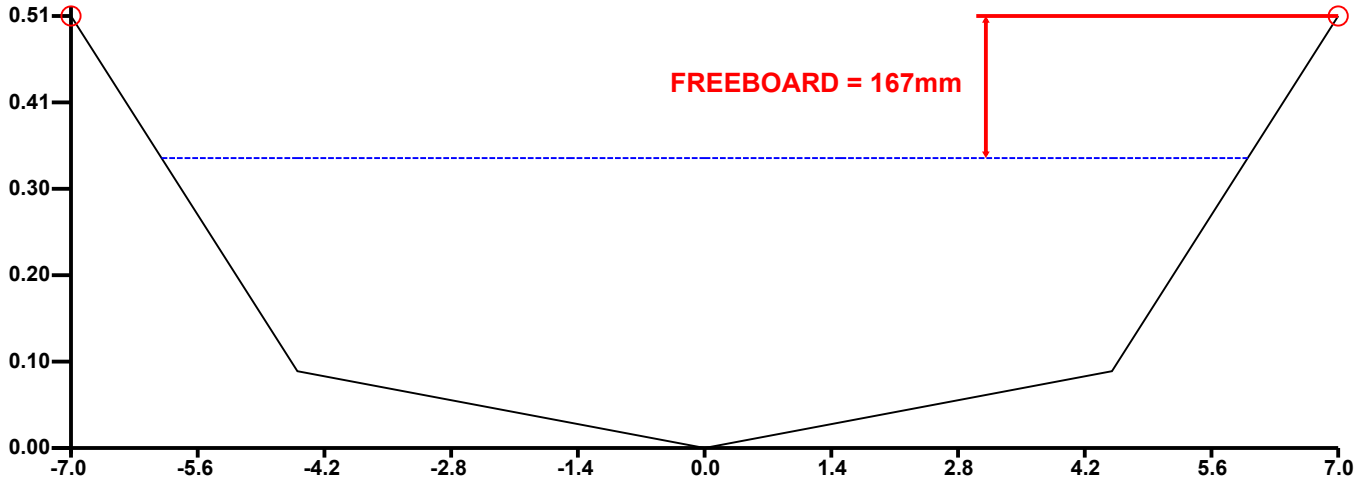

2. DISCHARGE INFORMATION:

100 year (1%) storm event

Total discharge = 3.69 cumecs

There is no pipe discharge

Overland/channel/watercourse discharge = 3.69 cumecs

3. RESULTS: Water surface elevation = 0.340m

Grade = 1 in 100

	<u>LEFT OVERBANK</u>	<u>MAIN CHANNEL</u>	<u>RIGHT OVERBANK</u>	<u>TOTAL CROSS-SECTION</u>
Discharge (cumecs):	0.00	3.89	0.00	3.89
D(Max) = Max. Depth (m):	0.00	0.34	0.00	0.34
D(Ave) = Ave. Depth (m):	0.00	0.25	0.00	0.25
V = Ave. Velocity (m/s):	0.00	1.29	0.00	1.29
D(Max) x V (cumecs/m):	0.00	0.44	0.00	0.44
D(Ave) x V (cumecs/m):	0.00	0.32	0.00	0.32
Froude Number:	0.00	0.82	0.00	0.82
Area (m ²):	0.00	3.03	0.00	3.03
Wetted Perimeter (m):	0.00	12.04	0.00	12.04
Flow Width (m):	0.00	12.00	0.00	12.00
Hydraulic Radius (m):	0.00	0.25	0.00	0.25
Composite Manning's n:	0.000	0.031	0.000	0.031
Split Flow?	-	-	-	No

4. CROSS-SECTION DATA:

<u>SEGMENT NO.</u>	<u>LEFT HAND POINT</u>		<u>RIGHT HAND POINT</u>		<u>MANNING'S N</u>
	<u>CHAINAGE (m)</u>	<u>R.L. (m)</u>	<u>CHAINAGE (m)</u>	<u>R.L. (m)</u>	
1	-7.000	0.507	-4.500	0.090	0.035
2	-4.500	0.090	-1.500	0.030	0.035
3	-1.500	0.030	0.000	0.000	0.013
4	0.000	0.000	1.500	0.030	0.013
5	1.500	0.030	4.500	0.090	0.035
6	4.500	0.090	7.000	0.507	0.035

PROJECT: 20102.1 LFR Drainage Reserve

North of Kirkpatrick

Print-out date: 28/05/2020 - Time: 14:15

Data File: C:\Users\rebecca.saber...\20102.1 LFR drainage reserve (North of Kirkpatrick).dat

1. CROSS-SECTION:

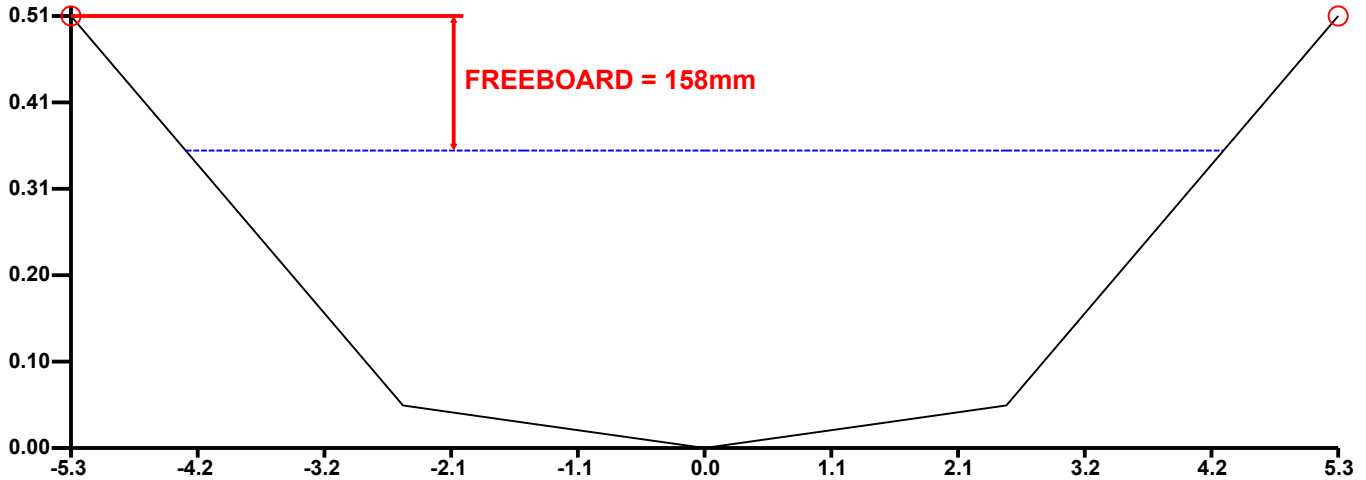

2. DISCHARGE INFORMATION:

100 year (1%) storm event

Total discharge = 2.84 cumecs

There is no pipe discharge

Overland/channel/watercourse discharge = 2.84 cumecs

3. RESULTS: Water surface elevation = 0.350m

Grade = 1 in 100

	<u>LEFT OVERBANK</u>	<u>MAIN CHANNEL</u>	<u>RIGHT OVERBANK</u>	<u>TOTAL CROSS-SECTION</u>
Discharge (cumecs):	0.00	2.93	0.00	2.93
D(Max) = Max. Depth (m):	0.00	0.35	0.00	0.35
D(Ave) = Ave. Depth (m):	0.00	0.25	0.00	0.25
V = Ave. Velocity (m/s):	0.00	1.36	0.00	1.36
D(Max) x V (cumecs/m):	0.00	0.47	0.00	0.47
D(Ave) x V (cumecs/m):	0.00	0.34	0.00	0.34
Froude Number:	0.00	0.86	0.00	0.86
Area (m ²):	0.00	2.17	0.00	2.17
Wetted Perimeter (m):	0.00	8.65	0.00	8.65
Flow Width (m):	0.00	8.60	0.00	8.60
Hydraulic Radius (m):	0.00	0.25	0.00	0.25
Composite Manning's n:	0.000	0.029	0.000	0.029
Split Flow?	-	-	-	No

4. CROSS-SECTION DATA:

<u>SEGMENT NO.</u>	<u>LEFT HAND POINT</u>		<u>RIGHT HAND POINT</u>		<u>MANNING'S N</u>
	<u>CHAINAGE (m)</u>	<u>R.L. (m)</u>	<u>CHAINAGE (m)</u>	<u>R.L. (m)</u>	
1	-5.250	0.508	-2.500	0.050	0.035
2	-2.500	0.050	-1.500	0.030	0.035
3	-1.500	0.030	0.000	0.000	0.013
4	0.000	0.000	1.500	0.030	0.013
5	1.500	0.030	2.500	0.050	0.035
6	2.500	0.050	5.250	0.508	0.035

Appendix E – Western Water Servicing Plans

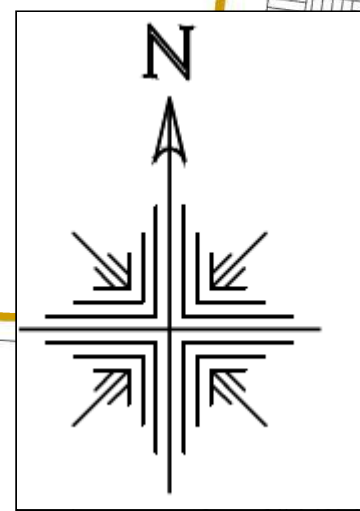

GRANGEFIELDS

BONNIE BROOK

HILL

FRASER RISE

AINTREE

ROCKBANK

DEANSIDE

TRUGANINA

MT. ATKINSON

— EXISTING SEWER GRAVITY MAIN
 - - - EXISTING SEWER RISING MAIN
 300 DENOTES PIPE SIZE
 2025 YEAR OF CONSTRUCTION
 - - - PROPOSED SEWER GRAVITY MAIN
 - - - PROPOSED SEWER RISING MAIN
 ● EXISTING SEWER PUMP STATION
 ● PROPOSED SEWER PUMP STATION
 — URBAN GROWTH BOUNDARY
 - - - CWW BOUNDARY
 ■ RECYCLED WATER PLANT

**ROCKBANK
 DEVELOPMENT SERVICING PLAN
 SEWER - Oct 2019
 Informing PS2020**

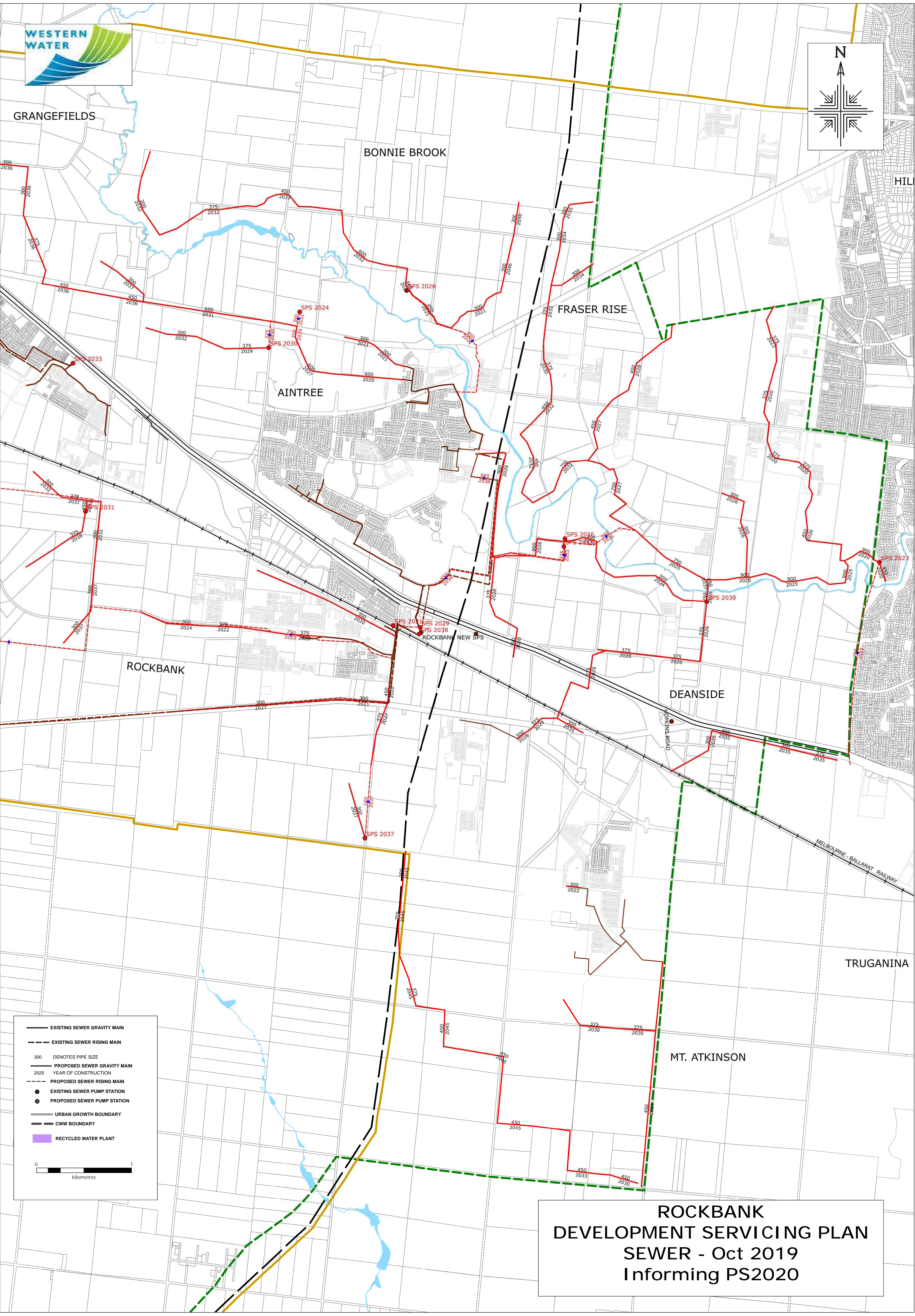

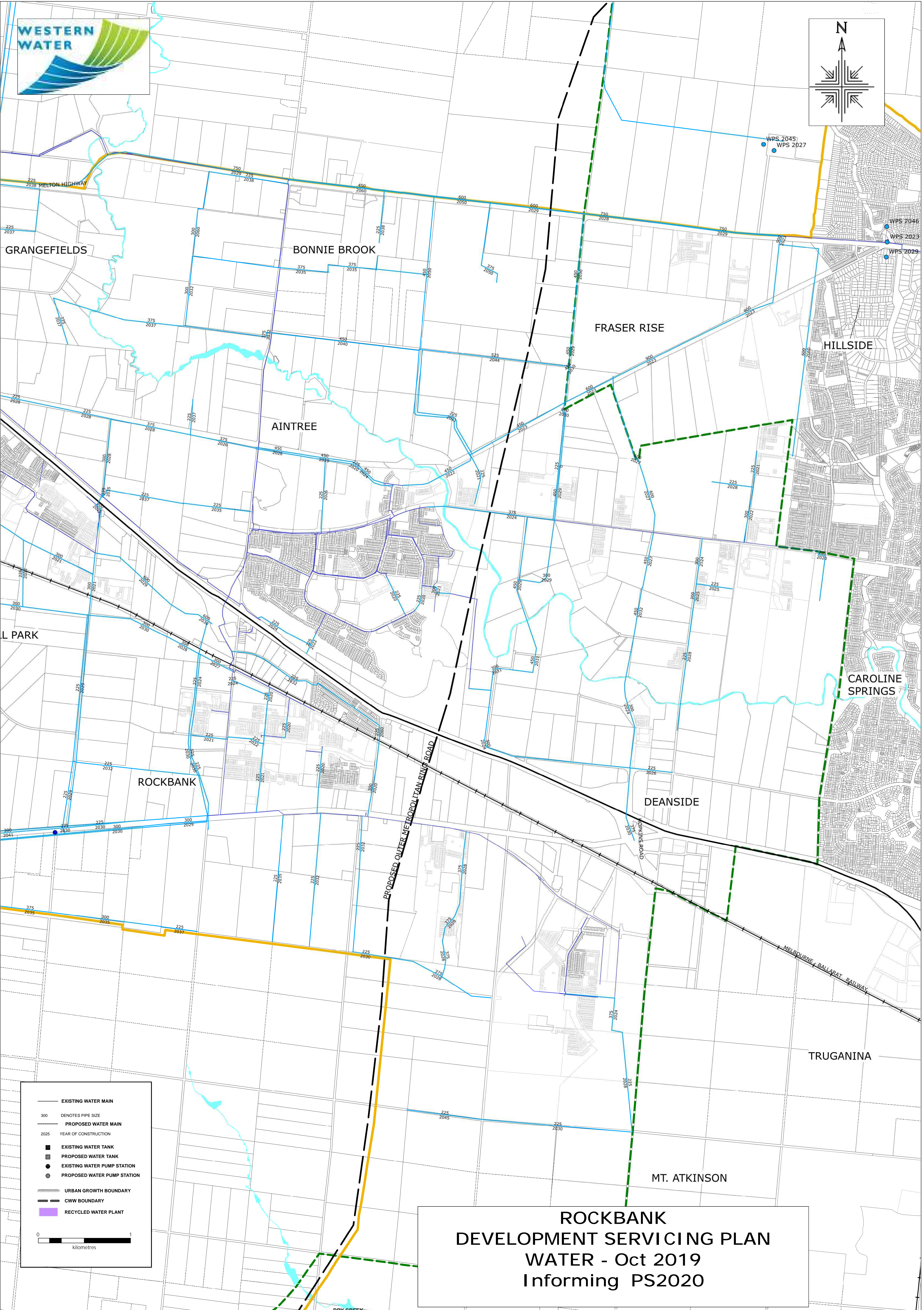
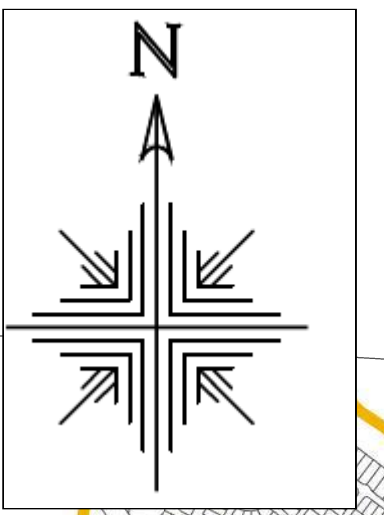

	EXISTING WATER MAIN
	300 DENOTES PIPE SIZE
	PROPOSED WATER MAIN
	2025 YEAR OF CONSTRUCTION
	EXISTING WATER TANK
	PROPOSED WATER TANK
	EXISTING WATER PUMP STATION
	PROPOSED WATER PUMP STATION
	URBAN GROWTH BOUNDARY
	CWW BOUNDARY
	RECYCLED WATER PLANT

0 1
kilometres

**ROCKBANK
DEVELOPMENT SERVICING PLAN
WATER - Oct 2019
Informing PS2020**

James Cappellari

From: Mary Tissaaratchi <Mary.Tissaaratchi@westernwater.com.au>
Sent: Monday, 6 April 2020 4:27 PM
To: James Cappellari
Cc: Rebecca Saber
Subject: [#20102-Mt Atkinson Town Centre] Email 2 of 2 Mt Atkinson Sewer Servicing

Existing new sewers

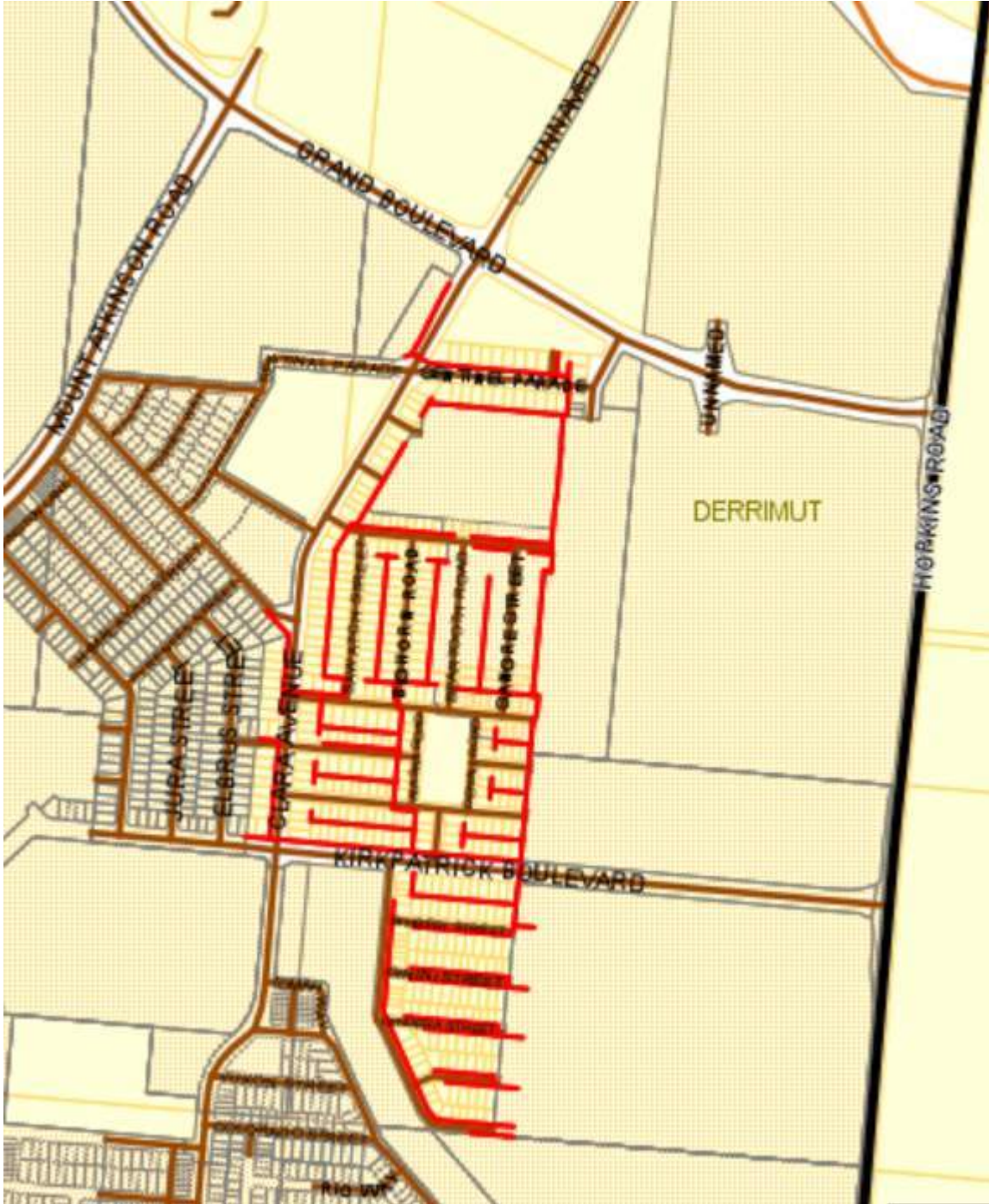

PROPOSED SEWERS

1. Proposed Grandview sewer (red line) – contractor appointed already

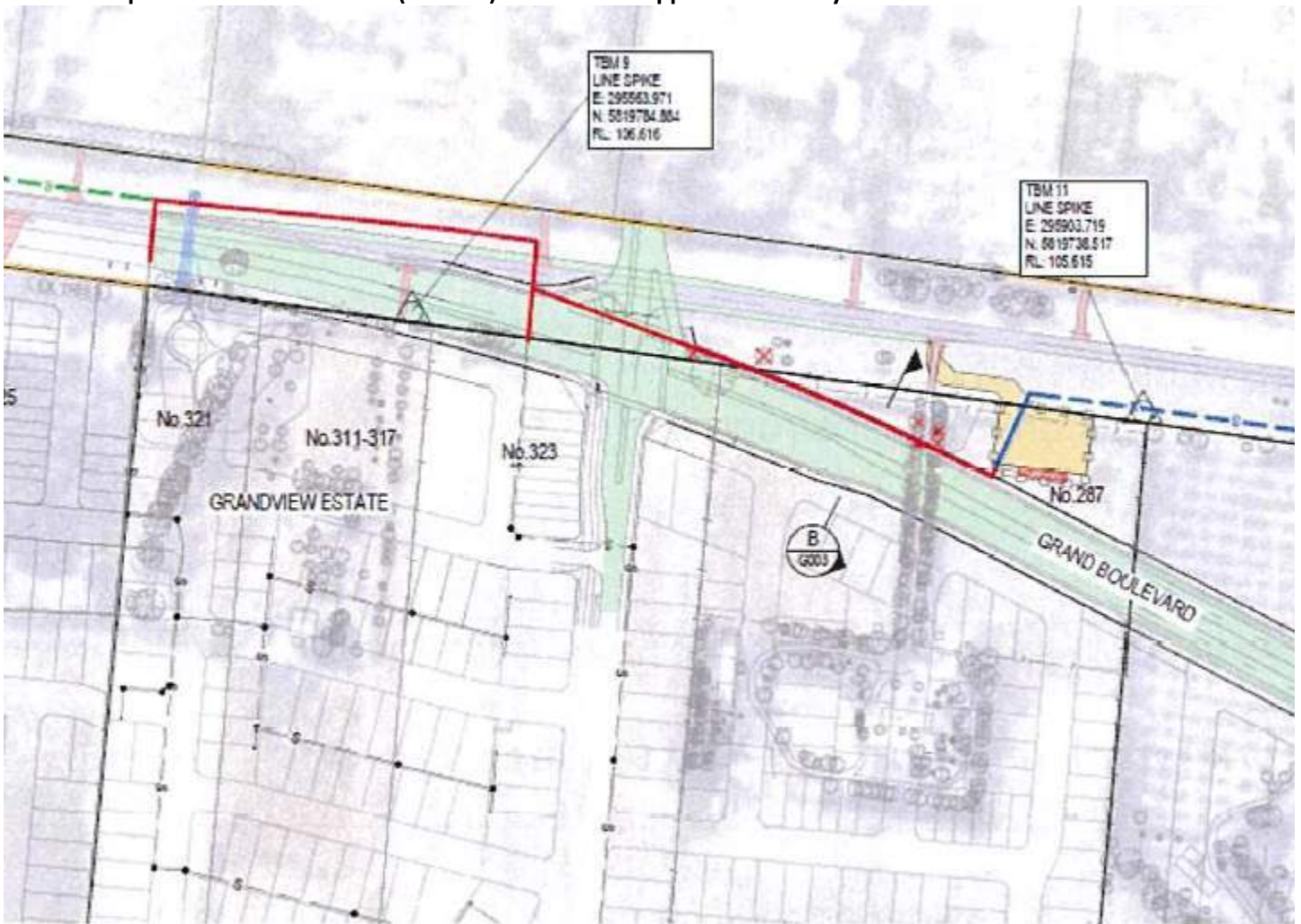

2. Proposed Sewer Future Extension (blue above) – Still being designed (early stage)

This blue sewer will connect to Hopkins Road sewer.

3. Proposed Hopkins Road sewer (solid red line with red circles below) – Design still being checked, tender to follow.

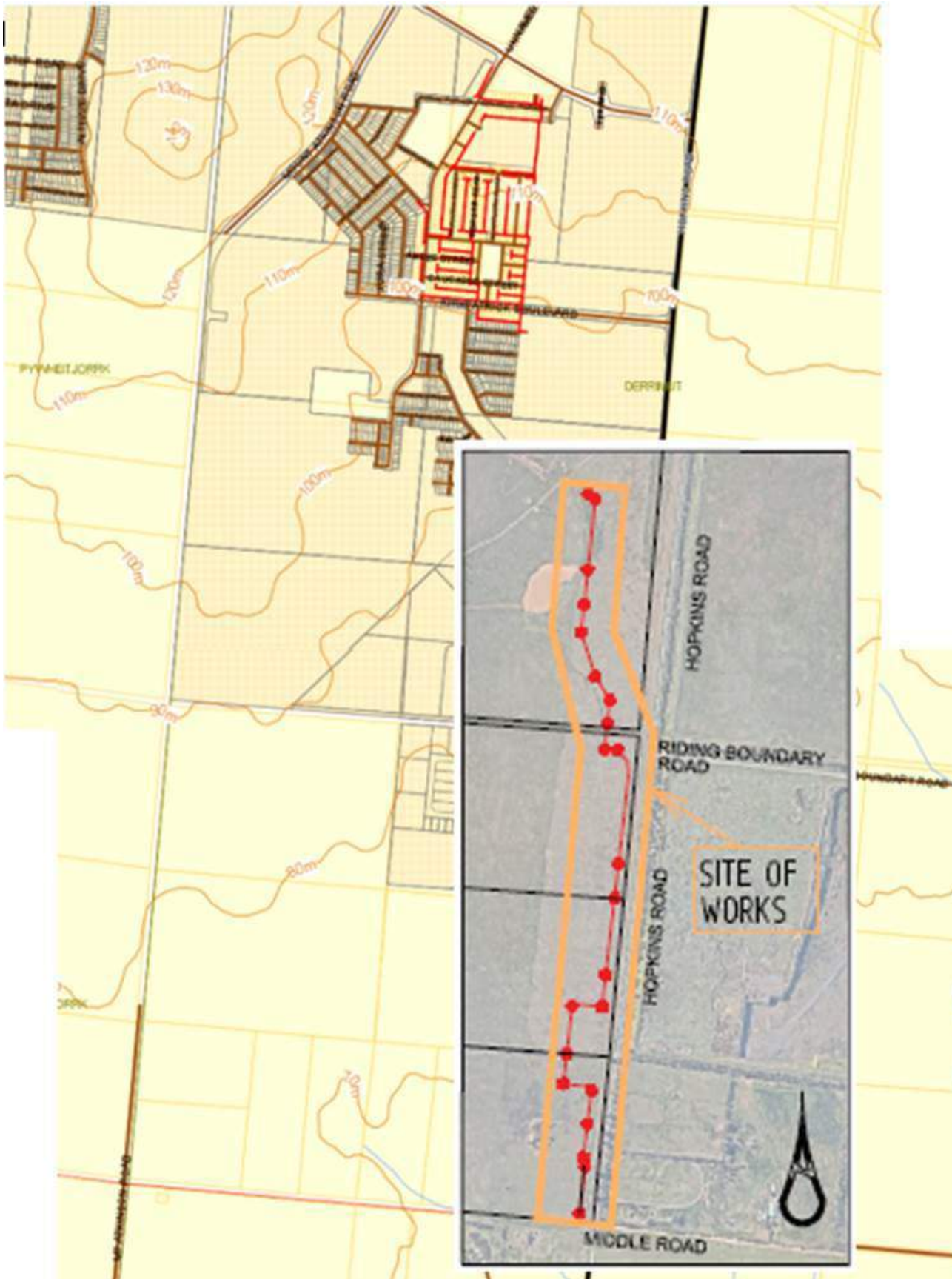

Hope this helps.

Kind regards



Mary Tissaaratchi | Senior Project Manager

P: (03) 9218 5469 | **M:** 0418 347 086

36 Macedon St, Sunbury 3429

P O Box 2371, Sunbury DC3429

From: James Cappellari <JamesC@dceng.com.au>

Sent: Monday, 6 April 2020 2:33 PM

To: Mary Tissaaratchi <Mary.Tissaaratchi@westernwater.com.au>

Cc: Rebecca Saber <RebeccaS@dceng.com.au>

Subject: [#20102-Mt Atkinson Town Centre] Mt Atkinson Servicing

Hi Mary,

Thanks for the chat, as discussed DCE have been engaged to work on the sites highlighted in blue below (town center and business area). Can you please provide preliminary servicing advice for these areas?

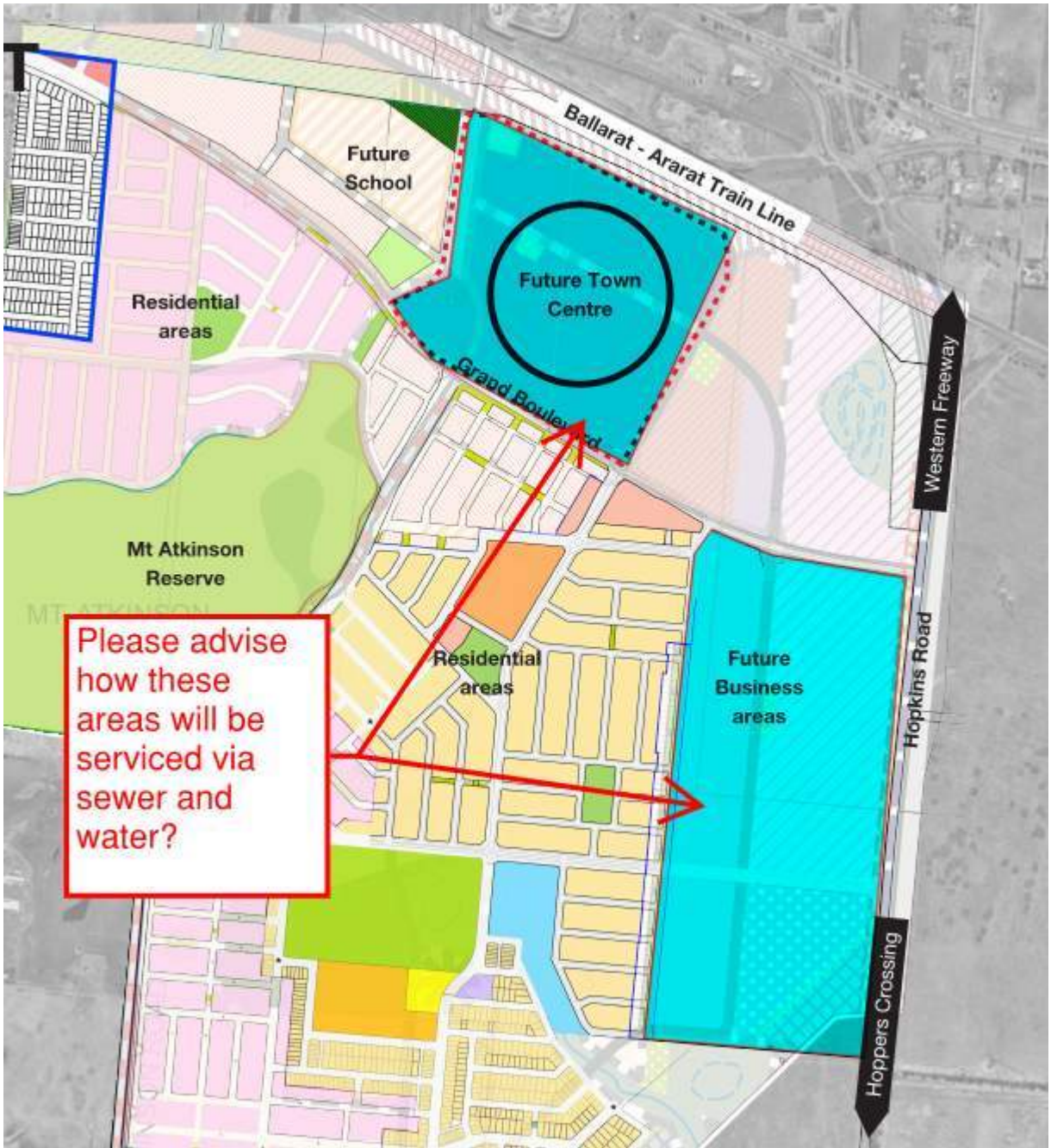

Thanks
James Cappellari
Project Manager



DALTON CONSULTING ENGINEERS PTY LTD

James Cappellari

From: Mary Tissaaratchi <Mary.Tissaaratchi@westernwater.com.au>
Sent: Monday, 6 April 2020 4:12 PM
To: James Cappellari
Cc: Rebecca Saber
Subject: [#20102-Mt Atkinson Town Centre] Email 1 of 2 : Mt Atkinson Water Servicing

Hi Janes,
I will send you second email showing sewer servicing.

Plan showing exiting new water mains – highlighted main 450 in size.

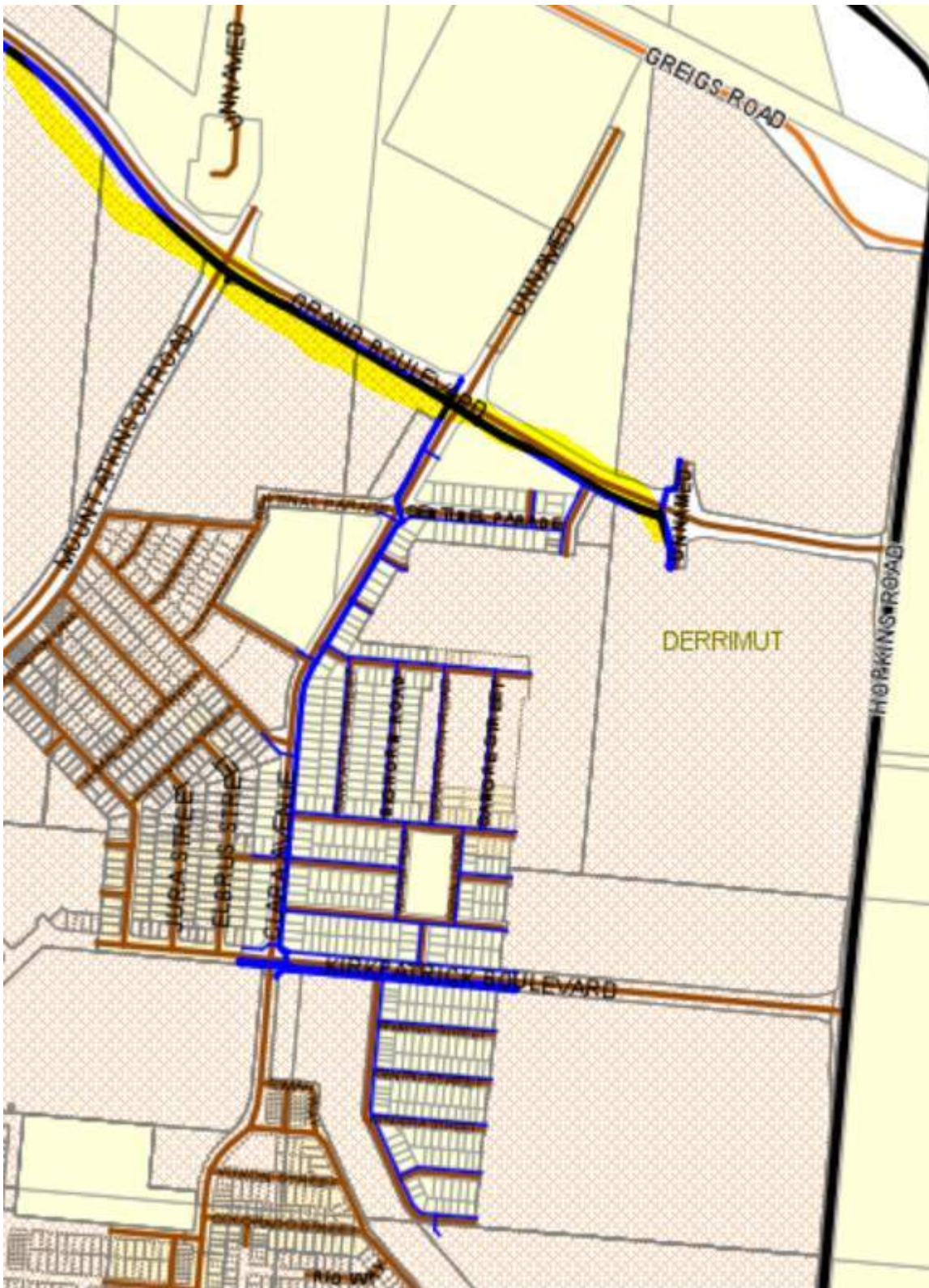

Proposed watermains to the south of Kirkpatrick Blvd



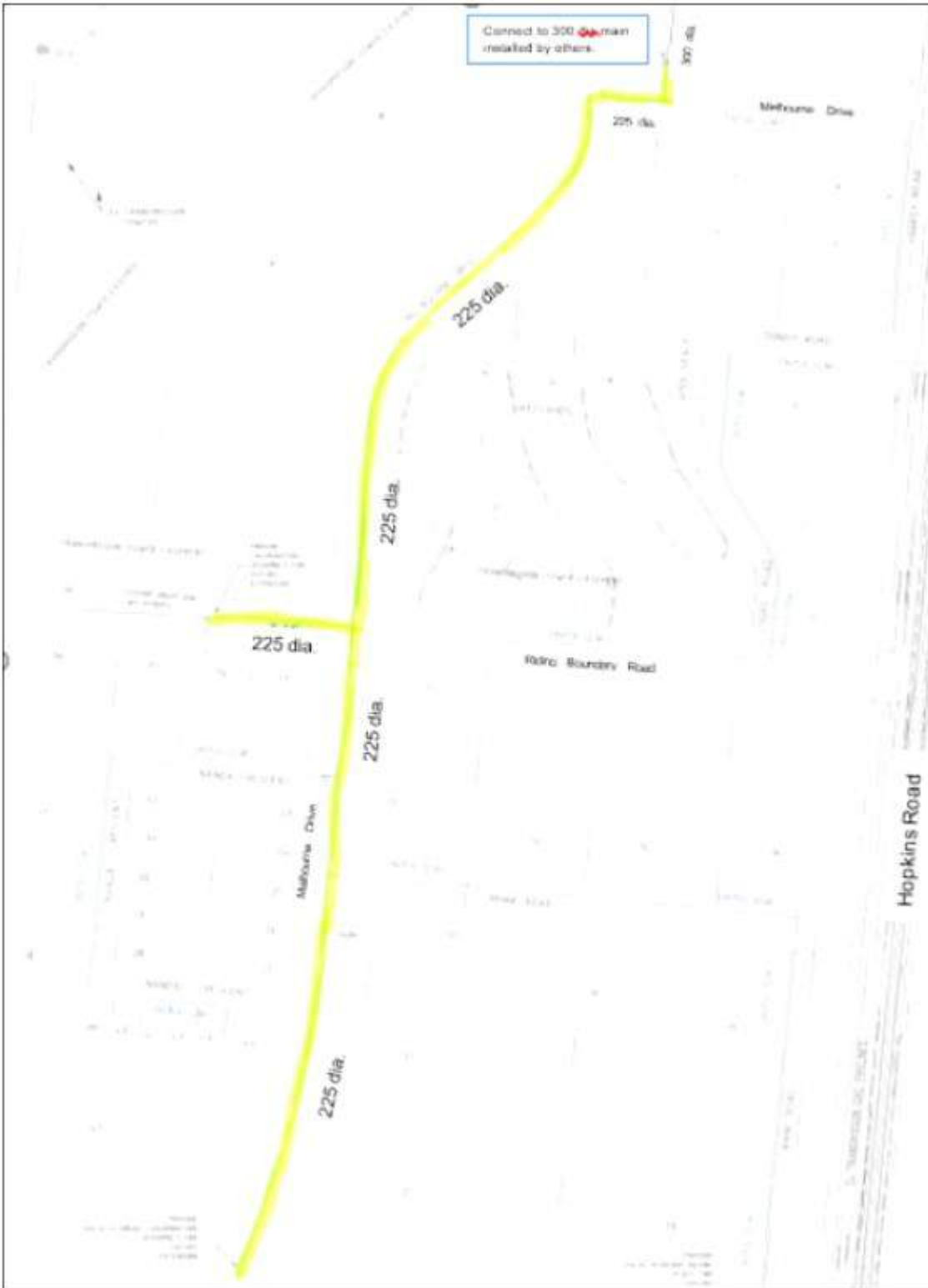

Kind regards



Mary Tissaaratchi | Senior Project Manager

P: (03) 9218 5469 | **M:** 0418 347 086

36 Macedon St, Sunbury 3429

P O Box 2371, Sunbury DC3429

Appendix F – Existing Water Main

FOR CONTINUATION SEE DRAWING NO. 31-33880-C464

FOR CONTINUATION SEE DRAWING NO. 31-33880-C466

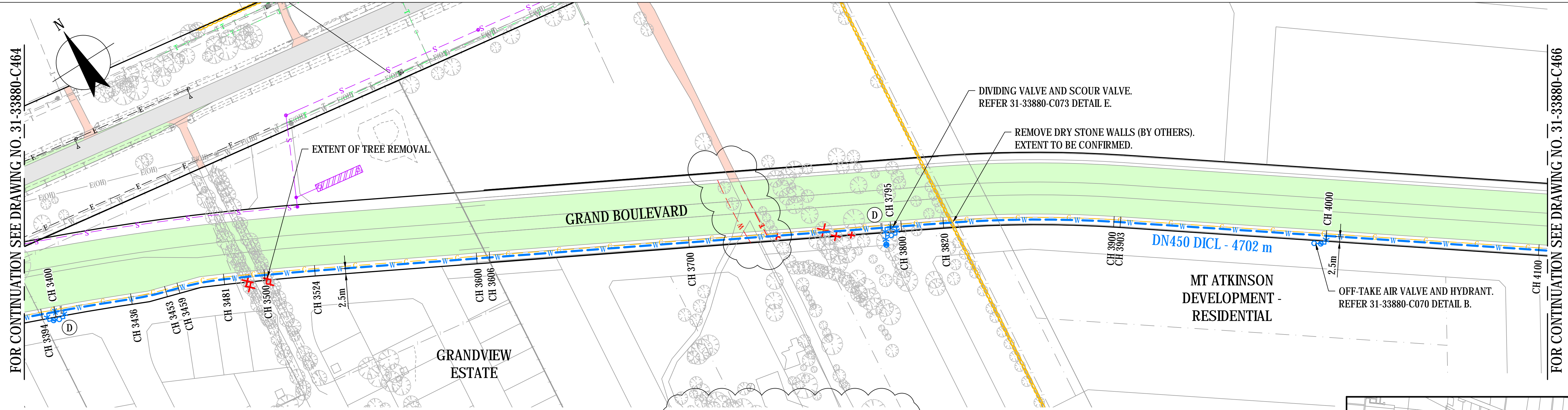

TRANSFER WATER PIPELINE - PLAN
SCALE 1:1000

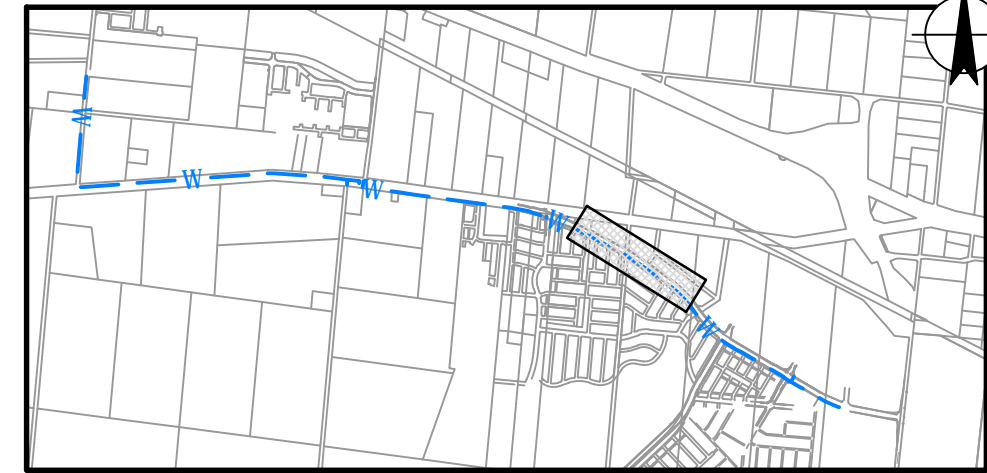

KEY PLAN
NTS

WARNING
SERVICES SHOWN ON THIS DRAWING ARE APPROXIMATE ONLY. THE EXACT LOCATIONS AND LEVELS ARE TO BE CONFIRMED ON SITE BY THE CONTRACTOR PRIOR TO COMMENCEMENT OF ANY WORKS. NO GUARANTEE IS GIVEN THAT ALL SERVICES ARE SHOWN ON THE DRAWINGS.

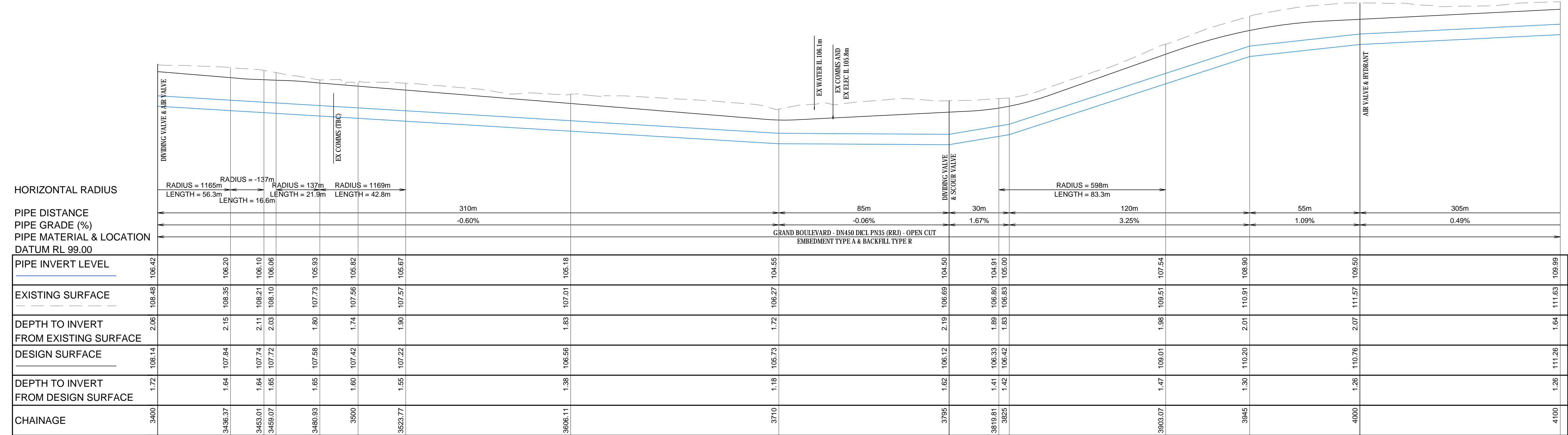

TRANSFER WATER PIPELINE - LONGITUDINAL SECTION
SCALE H:1000, V:100

CONSTRUCTION

No	Revision	Note	Drawn	Job Manager	Project Director	Date
1	UPDATED VERTICAL ALIGNMENT		AG	ES*	MW*	06.12.18
0	ISSUED FOR CONSTRUCTION		TC	ES*	MW*	20.11.18

VERTICAL 1:100 AT ORIGINAL SIZE
HORIZONTAL 1:1000 AT ORIGINAL SIZE

Level 8, 180 Lonsdale Street, Melbourne VIC 3000 Australia
T 61 3 8687 8000 F 61 3 8687 8111
E mel@mail@ghd.com.au W www.ghd.com

DO NOT SCALE

Conditions of Use:
This document may only be used by GHD's client (and any other person who GHD has agreed can use this document) for the purpose for which it was prepared and must not be used by any other person or for any other purpose.

Drawn	R. DELA CRUZ	Designed	A. GUNAWARDENA
Drafting Check	E.SAAD*	Design Check	E.SAAD*
Approved (Project Director)	M.WHALEN*		
Date	20.11.18		
Scale	AS SHOWN		

This Drawing must not be used for Construction unless signed as Approved

Client **STOCKLAND**
Project **MT ATKINSON HEADWORKS**
Title **TRANSFER WATER PIPELINE PLAN AND LONGITUDINAL SECTION - SHEET 6 OF 8**

Original Size **A1** Drawing No: **31-33880-C465** Rev: **1**

FOR CONTINUATION SEE DRAWING NO. 31-33880-C465

FOR CONTINUATION SEE DRAWING NO. 31-33880-C467

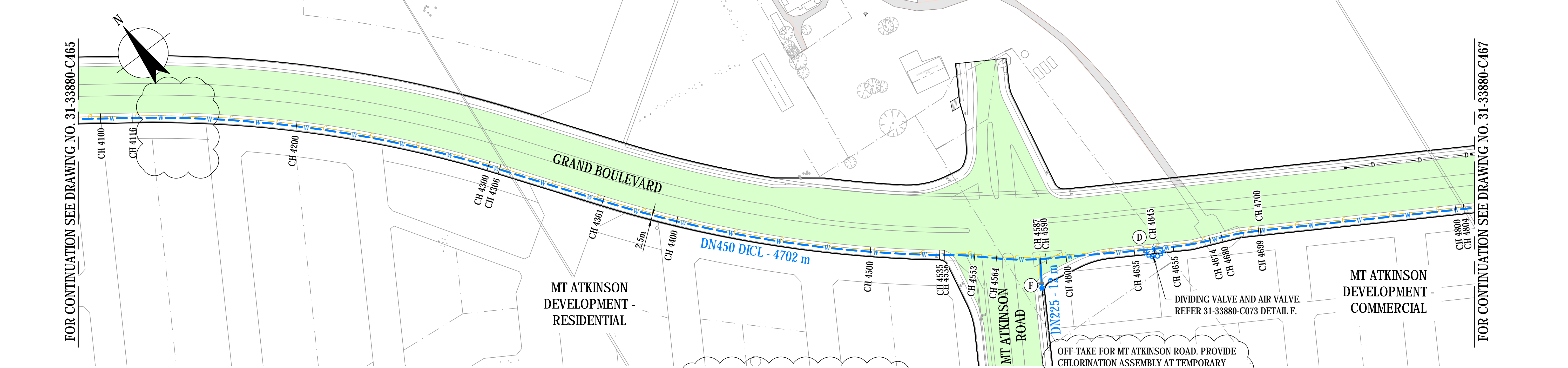

TRANSFER WATER PIPELINE - PLAN
SCALE 1:1000

OFF-TAKE FOR MT ATKINSON ROAD. PROVIDE CHLORINATION ASSEMBLY AT TEMPORARY END OF LINE. PIPE TO BE RESTRAINED BETWEEN TEE AND INLINE THRUST BLOCK. E: 296653.600 N: 5819030.372



KEY PLAN
NTS

WARNING
SERVICES SHOWN ON THIS DRAWING ARE APPROXIMATE ONLY. THE EXACT LOCATIONS AND LEVELS ARE TO BE CONFIRMED ON SITE BY THE CONTRACTOR PRIOR TO COMMENCEMENT OF ANY WORKS. NO GUARANTEE IS GIVEN THAT ALL SERVICES ARE SHOWN ON THE DRAWINGS.

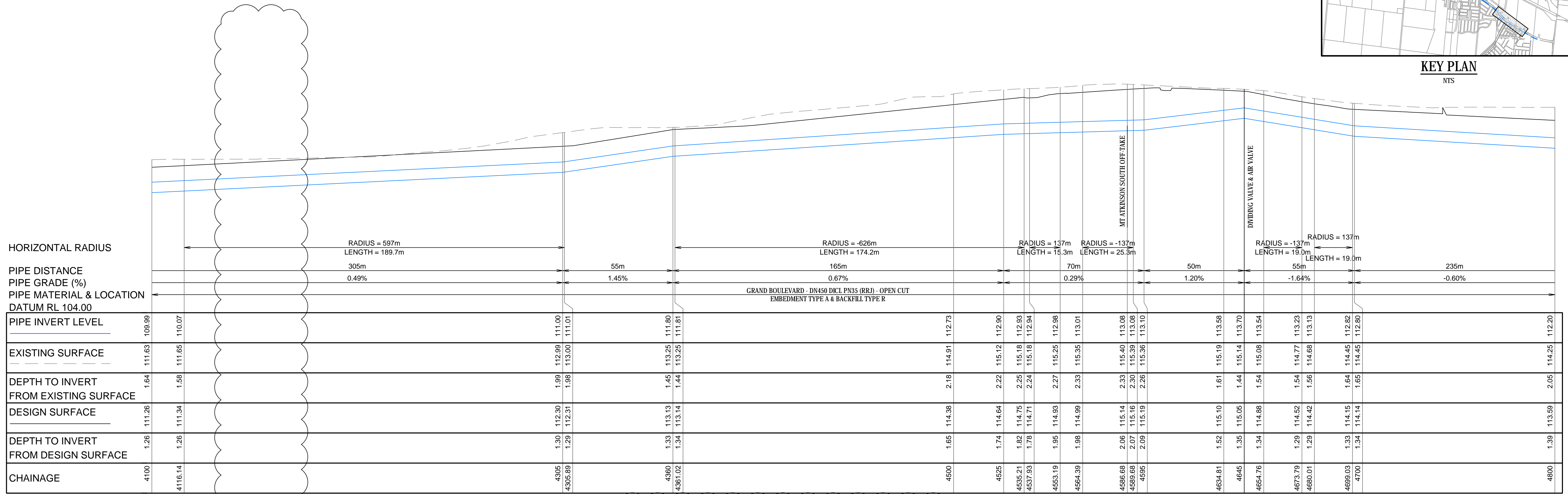

TRANSFER WATER PIPELINE - LONGITUDINAL SECTION
SCALE H1:1000, V1:100

CONSTRUCTION

No	Revision	Note	Drawn	Job Manager	Project Director	Date
1	UPDATED VERTICAL ALIGNMENT		AG	ES*	MW*	06.12.18
0	ISSUED FOR CONSTRUCTION		TC	ES*	MW*	20.11.18

Stockland

VERTICAL 1:100 AT ORIGINAL SIZE
HORIZONTAL 1:1000 AT ORIGINAL SIZE

MOUNT ATKINSON HOLDINGS
PTY.LTD

GHD

Level 8, 180 Lonsdale Street, Melbourne VIC 3000 Australia
T 61 3 8687 8000 F 61 3 8687 8111
E mel@mail@ghd.com.au W www.ghd.com

DO NOT SCALE

Conditions of Use:
This document may only be used by GHD's client (and any other person who GHD has agreed can use this document) for the purpose for which it was prepared and must not be used by any other person or for any other purpose.

Drawn: R. DELA CRUZ
Designed: A.GUNAWARDENA
Drafting Check: E.SAAD*
Design Check: E.SAAD*
Approved (Project Director): M.WHALEN*
Date: 20.11.18
Scale: AS SHOWN

Client: **STOCKLAND**
Project: **MT ATKINSON HEADWORKS**
Title: **TRANSFER WATER PIPELINE PLAN AND LONGITUDINAL SECTION - SHEET 7 OF 8**

Original Size: **A1**
Drawing No: **31-33880-C466**
Rev: **1**

This Drawing must not be used for Construction unless signed as Approved

FOR CONTINUATION SEE DRAWING NO. 31-33880-C466

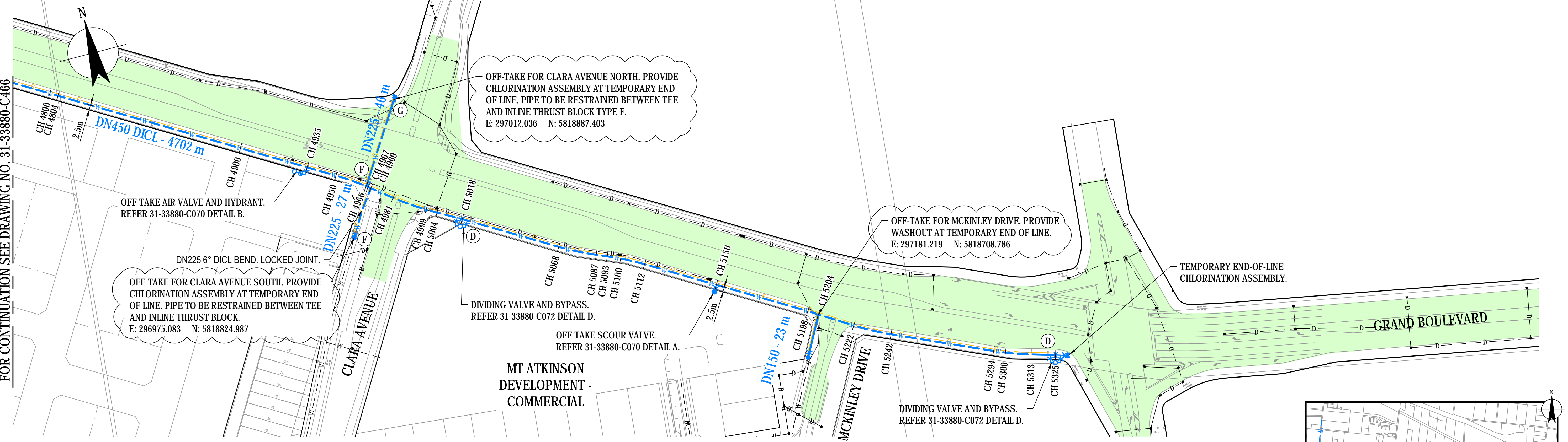

WARNING
 SERVICES SHOWN ON THIS DRAWING ARE APPROXIMATE ONLY. THE EXACT LOCATIONS AND LEVELS ARE TO BE CONFIRMED ON SITE BY THE CONTRACTOR PRIOR TO COMMENCEMENT OF ANY WORKS. NO GUARANTEE IS GIVEN THAT ALL SERVICES ARE SHOWN ON THE DRAWINGS.

TRANSFER WATER PIPELINE - PLAN
 SCALE 1:1000



KEY PLAN
 NTS

PIPE DISTANCE	PIPE GRADE (%)	PIPE MATERIAL & LOCATION	DATUM RL 103.00
235m	-0.60%	DN450 DI CL	112.20
18m	-4.44%	DN225 DI CL	111.40
87m	-0.34%	DN225 DI CL	110.44
110m	-1.18%	DN450 DI CL	109.74
45m	1.11%	DN450 DI CL	109.50
35m	0.86%	DN450 DI CL	109.53
6m	1.67%	DN450 DI CL	109.57
89.34m	0.57%	DN450 DI CL	110.23

PIPE INVERT LEVEL	EXISTING SURFACE	DEPTH TO INVERT FROM EXISTING SURFACE	DESIGN SURFACE	DEPTH TO INVERT FROM DESIGN SURFACE	CHAINAGE
112.20	114.25	2.05	113.59	1.39	4800
111.40	114.26	2.08	113.57	1.39	4804.24
111.40	113.87	2.47	112.92	1.52	4935
110.73	113.78	3.05	112.84	2.12	4950.12
110.60	113.75	3.15	112.83	2.23	4953
110.55	113.62	3.07	112.73	2.18	4966.27
110.55	113.61	3.06	112.70	2.15	4967.37
110.55	113.59	3.05	112.64	2.09	4968.85
110.50	113.47	2.97	112.42	1.92	4981.06
110.44	113.19	2.75	112.41	1.96	4988.77
110.44	113.17	2.73	112.43	1.99	5000
110.42	113.09	2.67	112.41	1.99	5004.41
110.38	112.88	2.50	112.26	1.89	5017.55
110.30	112.51	2.21	111.92	1.62	5040
109.97	112.05	2.08	111.48	1.51	5068.19
109.74	111.72	1.99	111.22	1.48	5087.5
109.67	111.63	1.95	111.16	1.46	5093.1
109.44	111.32	1.88	110.89	1.45	5112.4
109.00	111.17	2.17	110.44	1.44	5150
109.50	111.25	1.75	111.25	1.75	5195
109.53	111.25	1.73	111.25	1.73	5198.04
109.57	111.27	1.69	111.27	1.69	5203.63
109.73	111.35	1.62	111.35	1.62	5222.29
109.80	111.37	1.57	111.51	1.71	5230
109.90	111.38	1.48	111.55	1.65	5236
109.93	111.40	1.46	111.58	1.65	5241.62
110.23	111.92	1.69	111.84	1.61	5293.86
110.34	111.99	1.65	111.90	1.56	5313.04
110.41	111.97	1.56	111.90	1.49	5325.34

TRANSFER WATER PIPELINE - LONGITUDINAL SECTION
 SCALE H1:1000, V1:100

CONSTRUCTION

No	Revision	Note	Drawn	Job Manager	Project Director	Date
1	UPDATED CLARA CROSSING AND CHAINAGES		AG	ES*	MW*	06.12.18
0	ISSUED FOR CONSTRUCTION		TC	ES*	MW*	20.11.18

Stockland

VERTICAL 1:100 AT ORIGINAL SIZE
 HORIZONTAL 1:1000 AT ORIGINAL SIZE

MOUNT ATKINSON HOLDINGS
 PTY.LTD

GHD

Level 8, 180 Lonsdale Street, Melbourne VIC 3000 Australia
 T 61 3 8687 8000 F 61 3 8687 8111
 E mel@mail@ghd.com.au W www.ghd.com

DO NOT SCALE

Conditions of Use:
 This document may only be used by GHD's client (and any other person who GHD has agreed can use this document) for the purpose for which it was prepared and must not be used by any other person or for any other purpose.

Drawn	R. DELA CRUZ	Designed	A.GUNAWARDENA
Drafting Check	E.SAAD*	Design Check	E.SAAD*
Approved (Project Director)	M.WHALEN*		
Date	20.11.18		
Scale	AS SHOWN		

This Drawing must not be used for Construction unless signed as Approved

STOCKLAND
MT ATKINSON HEADWORKS
TRANSFER WATER PIPELINE
PLAN AND LONGITUDINAL SECTION - SHEET 8 OF 8

Client Project Title
 Original Size Drawing No: **31-33880-C467** Rev: 1

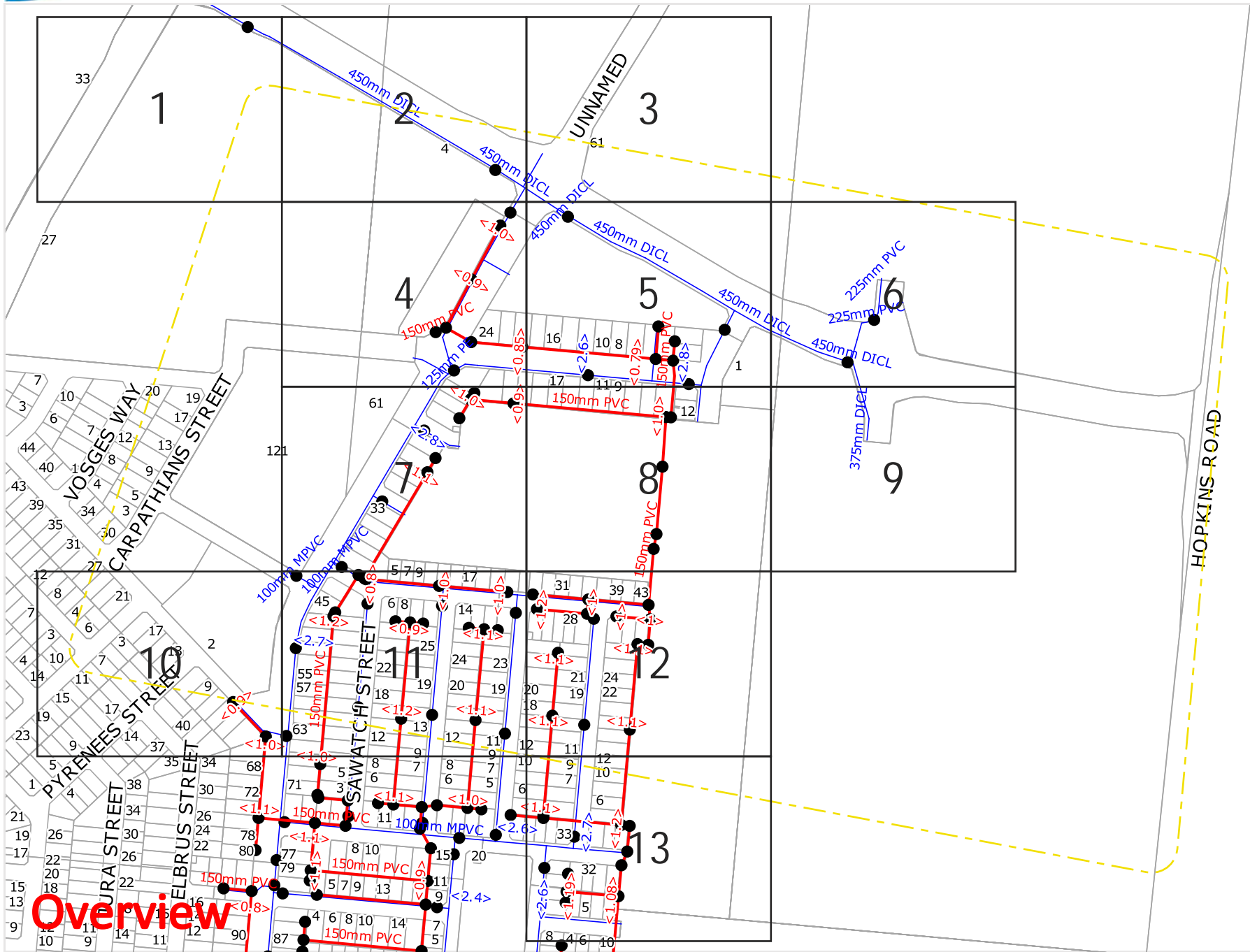

Overview

Legend:

- Gravity Sewer
- - - Pressure Sewer
- Vacuum Pipe
- Water Potable
- Water Recycled
- Water Raw
- - - Abandoned Pipes
- Surface Fitting/Manhole
- <1.2> Estimated Offset

NOTE: Assets labelled "AC" may contain asbestos material and therefore any works near these assets must be undertaken in accordance with OHS (Asbestos) Regulations 2007.

Due to the placement of Potable and Recycled pipes in the same trench, it may be difficult to distinguish the two asset types where they have been superimposed on the plans.

PLANS MUST BE PRINTED IN COLOUR



Scale: 1:5125
 Expires: 27 May 2020

DISCLAIMER: Western Region Water Corporation and PelicanCorp do not guarantee or make any representation or warranty as to the accuracy of this plan or associated details. It is provided in good faith as the best information available at the time. Western Region Water Corporation and PelicanCorp therefore accept no liability for any loss or injury by any party as a result of any inaccuracy in these plans.

Appendix G – Existing Electrical Assets

James Cappellari

From: Siobhan Anne Rehill <siobhan@ega.com.au>
Sent: Friday, 2 July 2021 2:05 PM
To: James Cappellari
Cc: Victoria Cook
Subject: FW: Servicing Advice for Mt A HRBP
Attachments: 2020-11-30 PCA40_6046710_2.pdf

From: Paktin Fazal <paktinf@planbservices.com.au>
Sent: Friday, 2 July 2021 1:58 PM
To: Siobhan Anne Rehill <siobhan@ega.com.au>
Cc: Jim Bozikis - PBC <jimb@planbcomms.com.au>
Subject: RE: Servicing Advice for Mt A HRBP

Hi Siobhan,

Just clarifying something for comms.

Powercor

With regards to electrical, there is existing HV 22Kv cable in Grand Bvd and planned in Kirkpatrick. Hopkins Rd currently has 22kV overhead conductor north of Grand Bvd.

This is the only feeder currently supplying Mt Atkinson Residential and is fairly substantially utilised. This feeder is MLN-21

There are spare conduits with the developed portions of Mt Atkinson that will form part of the overall supply and network strategy for the site. conduits and HV route shown on attached plan.

Griegs Rd doesn't have suitable conductor however will likely need interconnection. It would seem likely substantial works involved.

Recommend preparing and lodging a Powercor masterplan to have input from Powercor network planners for overall requirements.

As the precinct has substantial projects in progress and upcoming Powercor will need significant network upgrades. This is normally at their cost.

There is also a future zone substation allocated south of this subject site in Melbourne business park. Timing on the deliver if this is currently unknown and will be initiated once planned load justifies it. It was not anticipated for the next 3-5 years however may come forward.

I hope this assists.

Regards,

PAKTIN FAZAL

We have moved

Level 3, 545 Blackburn Road, MOUNT WAVERLEY, VIC, 3149

(03) 9501 2055 • 0439 000 114 • paktinf@planbservices.com.au



The information contained in this e-mail and any attachments are confidential and are intended solely for the use of the addressee or someone authorized to receive the addressee's e-mail. If you have received the e-mail in error, please notify the sender by return e-mail, delete the e-mail from your computer system and destroy any printed copy. There is no warranty that this email is error or virus free. It may be a private communication, and if so, does not represent the view of Plan B Services Pty Ltd.

From: Siobhan Anne Rehill <siobhan@ega.com.au>
Sent: Thursday, 1 July 2021 10:27 AM
To: Paktin Fazal <paktinf@planbservices.com.au>
Subject: Servicing Advice for Mt A HRBP

Hi Paktin,

Any progress on this advice. We would like to wrap up the servicing technical report for the UDF with the electrical and communications report. For clarity the HRBP UDF covers that land area bounded by:

- West Boundary Strathbogie Road
- East Boundary Hopkins Road
- North Greigs Road
- South Conondale Ave.

Let me know of any problems, high level, as I understand it from our conversation Plan B would need to make application to Powercor, this investigation should occur/commenced. However in the interim high level is satisfactory.

Regards,

Siobhan Rehill
Development Director

MT. ATKINSON

A NEW SUBURB
FOR MELBOURNE

Mount Atkinson Holdings Pty Ltd
Level 12, 468 St Kilda Road
Melbourne VIC 3004

PO Box 7709
St Kilda Road
Melbourne VIC 3004

M + 0418 175 689
T + 61 3 9866 6200
F + 61 3 9866 1766
E siobhan@ega.com.au

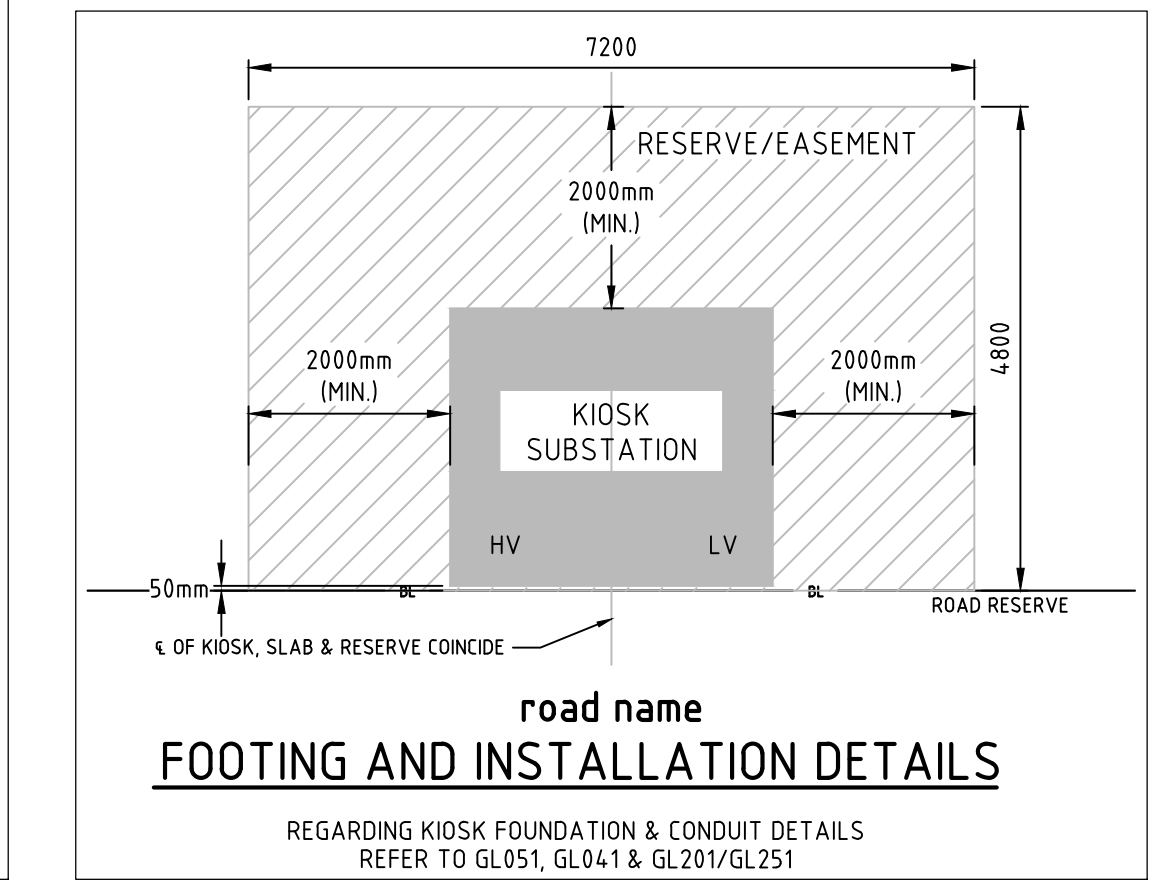
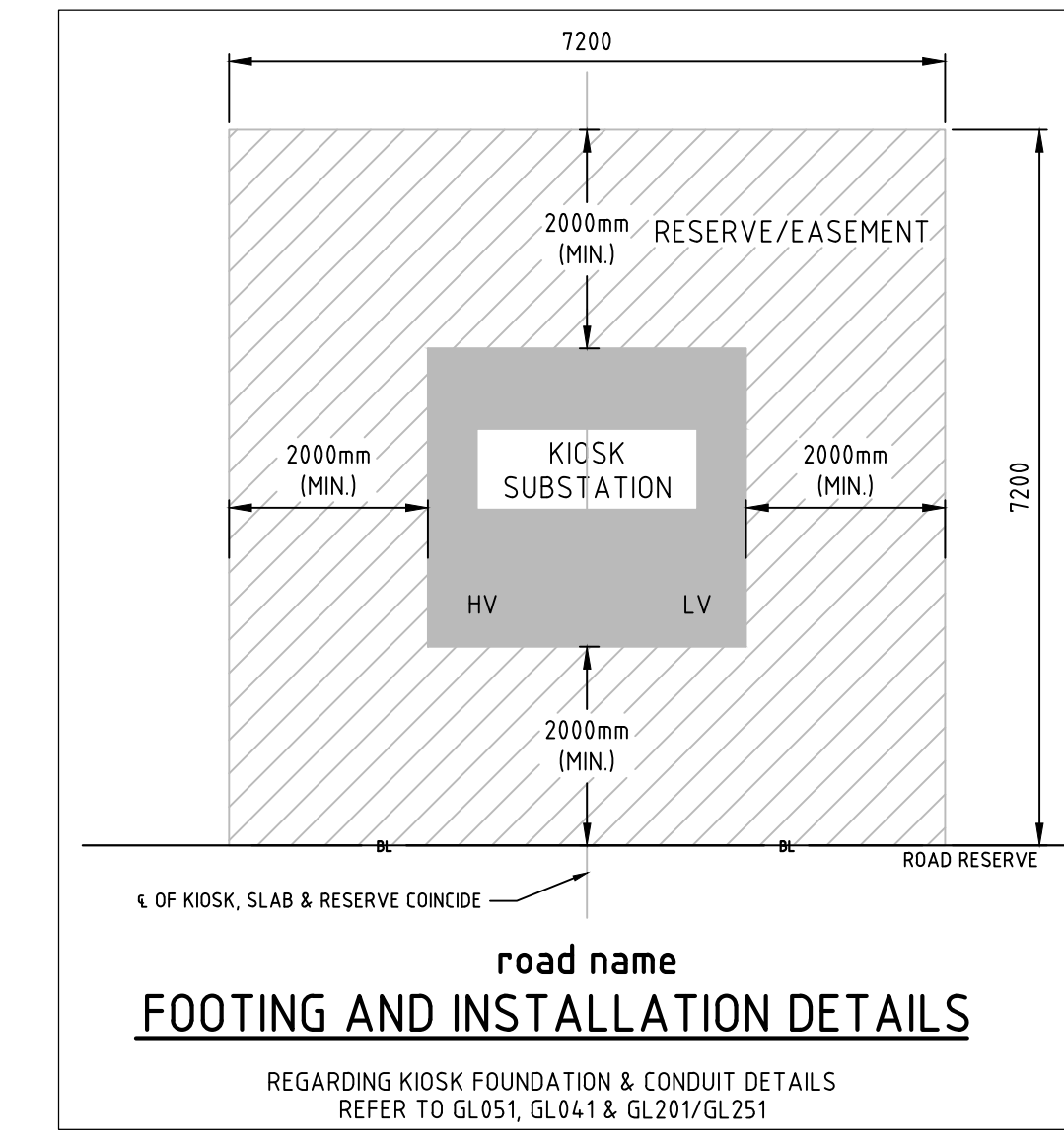
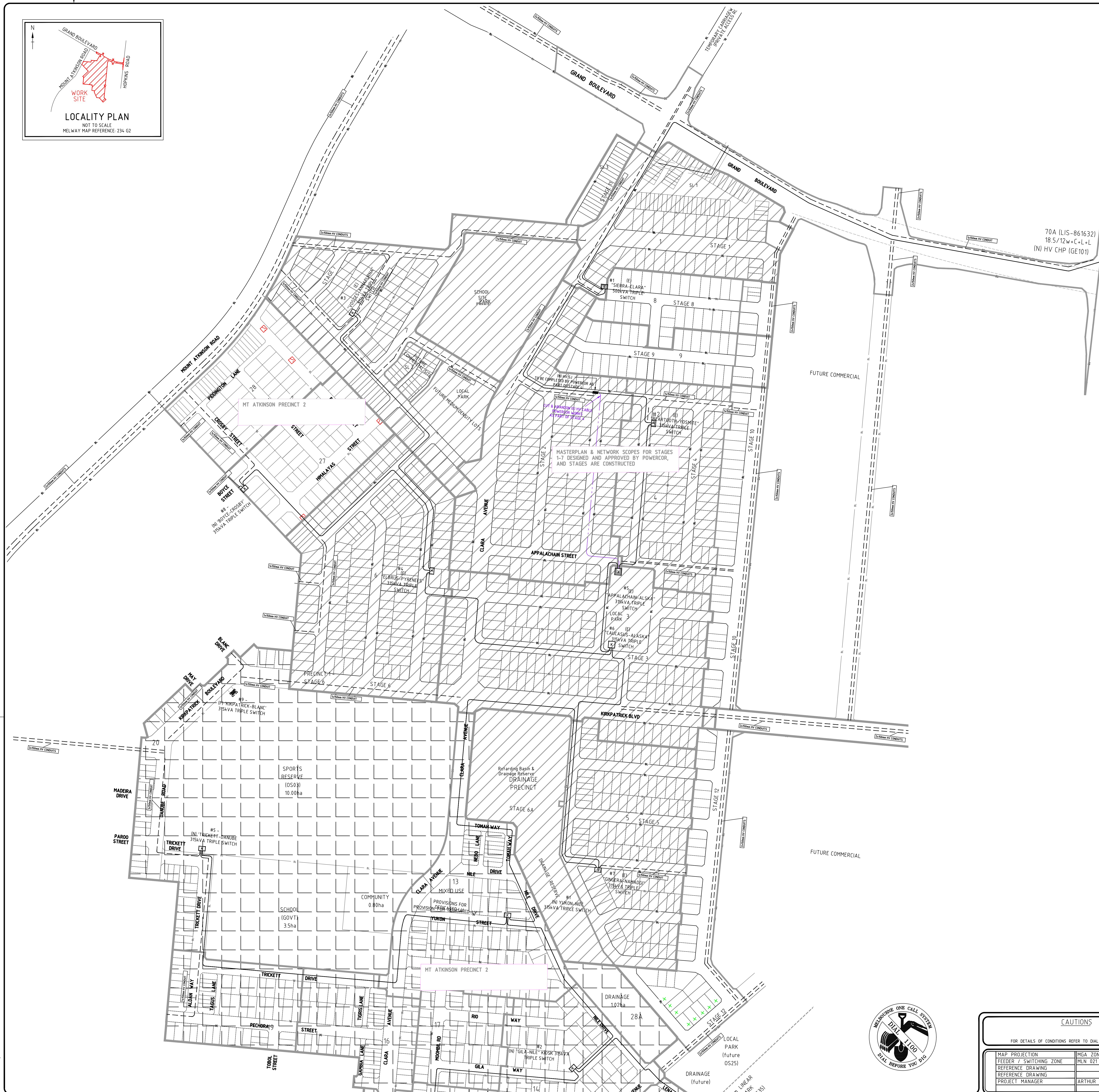
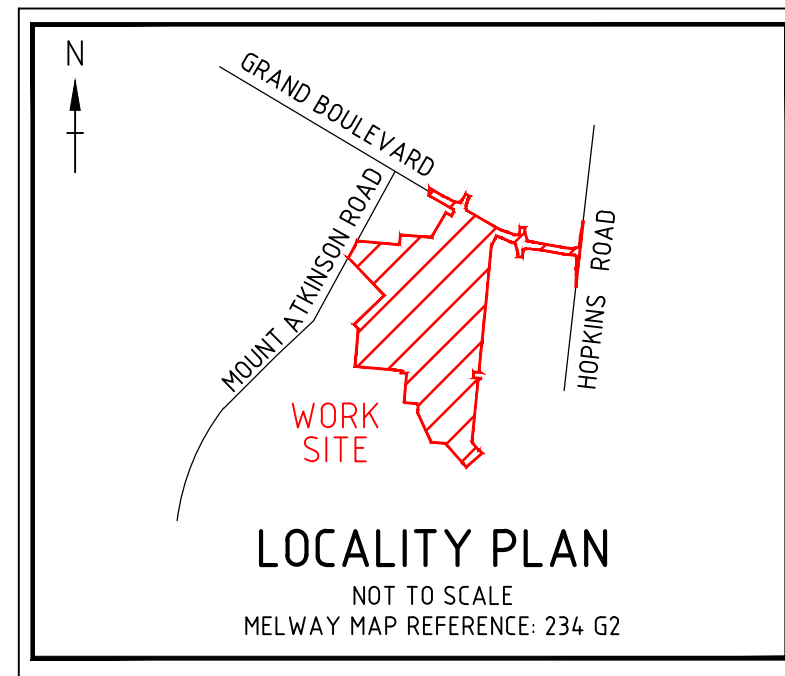

DEVELOPMENT STAGED ORDER

STAGE NUMBER	ORDER OF DEVELOPMENT	ESTIMATED "TIE IN" DATE
STAGE 10	1	JUNE 2020
STAGE 8	2	xxxx 2021
STAGE 9	3	xxxx 2021
STAGE 12	4	xxxx 2021
	5	
	6	
	7	
	8	



LEGEND

- (N) 185/240 3c 22 a.x.h.c.h.
- (N) 150 HV CONDUIT
- (E) 185/240 3c 22 a.x.h.c.h.
- (E) 150 HV CONDUIT
- (N) KIOSK
- (N) SWITCHGEAR CABINET
- (E) KIOSK
- (E) SWITCHGEAR CABINET
- HV CHP

LEGEND

- PRECINCT 1
- PRECINCT 2

HV SCHEMATIC FOUND IN SHEET 3

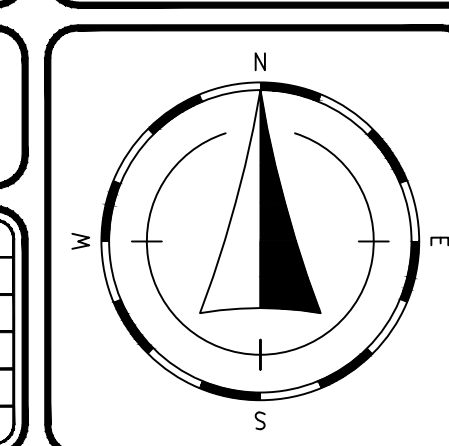
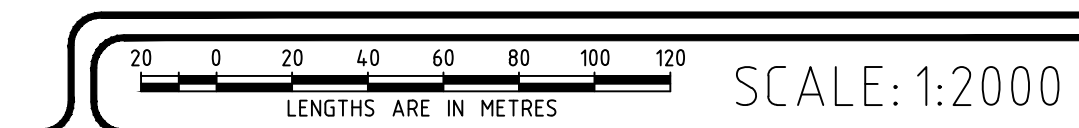

CAUTIONS

FOR DETAILS OF CONDITIONS REFER TO DIAL BEFORE YOU DIG INFORMATION

MAP PROJECTION	MGA ZONE 55
FEEDER / SWITCHING ZONE	MLN 021
REFERENCE DRAWING	
PROJECT MANAGER	ARTHUR KOUZOUIMS

DRAWING NUMBER	PCA40_6046710	2	SHEET 2 OF 3
JRD MASTER PLAN (HV) MT ATKINSON DEVELOPMENT (PRECINCT 1) GRAND BOULEVARD TRUGANINA			
DRAWN	PLAN B (L1)	DRAFTING CHECK	DESIGNER
08/10/20		08/10/20	08/10/20

CABLE SCHEDULE			
CABLE ID	LOCATION	DETAILS	LENGTH
LV MAINS CABLE			
(N) LV1	FROM SJ (A) WESTERN END OF GRAND BLVD TO PP (B) WEST OF INDUSTRIAL LINK	240 4c LV s.a.x.	275m
(N) LV2	FROM PP (B) WEST OF INDUSTRIAL LINK TO LV IE (C) EAST END OF GRAND BLVD	240 4c LV s.a.x.	395m
(N) LV3	FROM MT J (H) WEST OF INDUSTRIAL LINK TO LV IE (C) MCKINLEY DRIVE	240 4c LV s.a.x.	125m
(N) LV4	FROM MT J (H) EAST OF INDUSTRIAL LINK TO LV IE (C) STRATHBOGIE DRIVE (NORTH)	240 4c LV s.a.x.	90m
(N) LV5	FROM MT J (H) EAST OF INDUSTRIAL LINK TO LV IE (C) STRATHBOGIE DRIVE (SOUTH)	240 4c LV s.a.x.	100m
SERVICE CABLE			
		16 4c LV c.x.	550m
		6 2c LV c.x.	220m

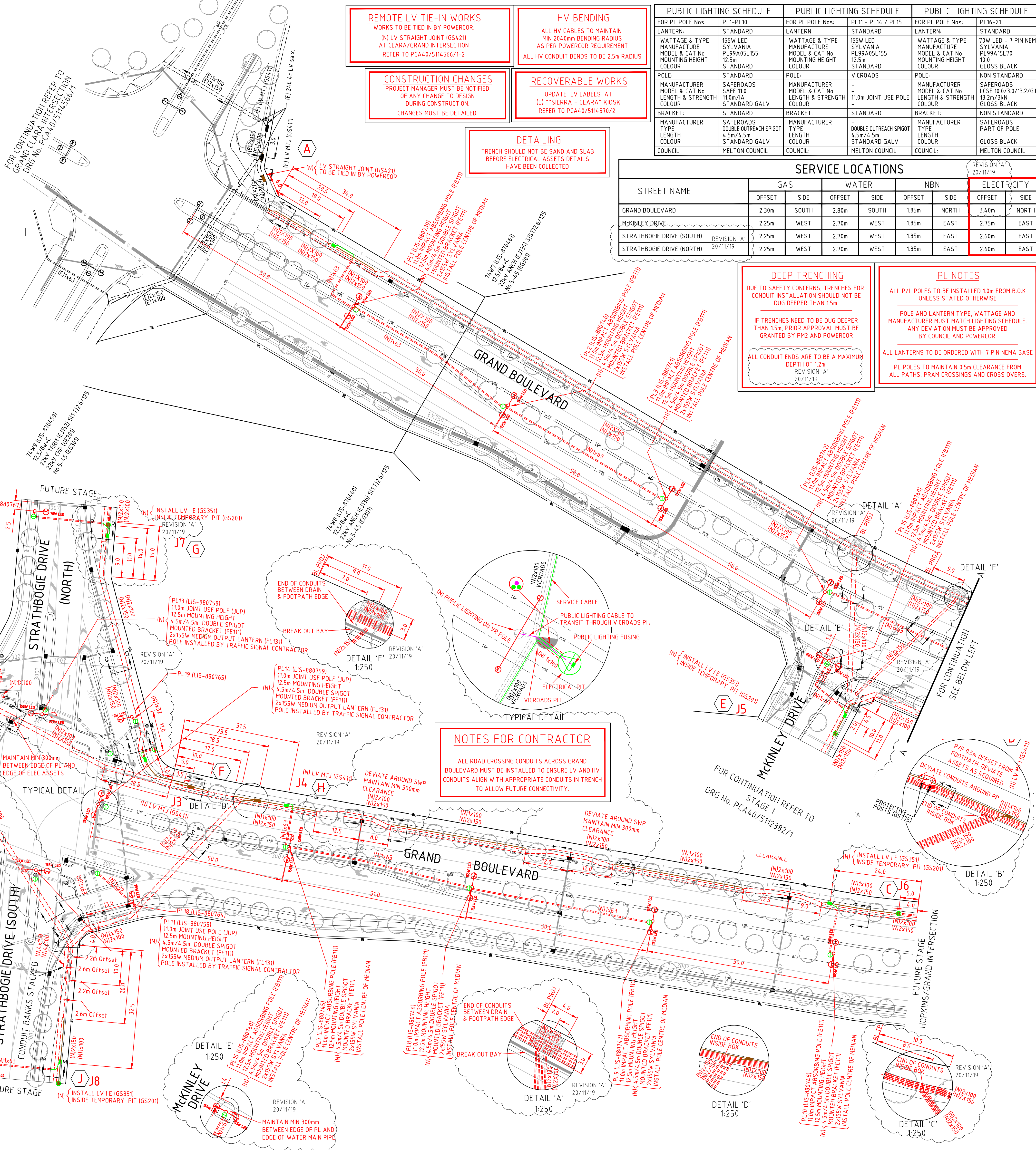
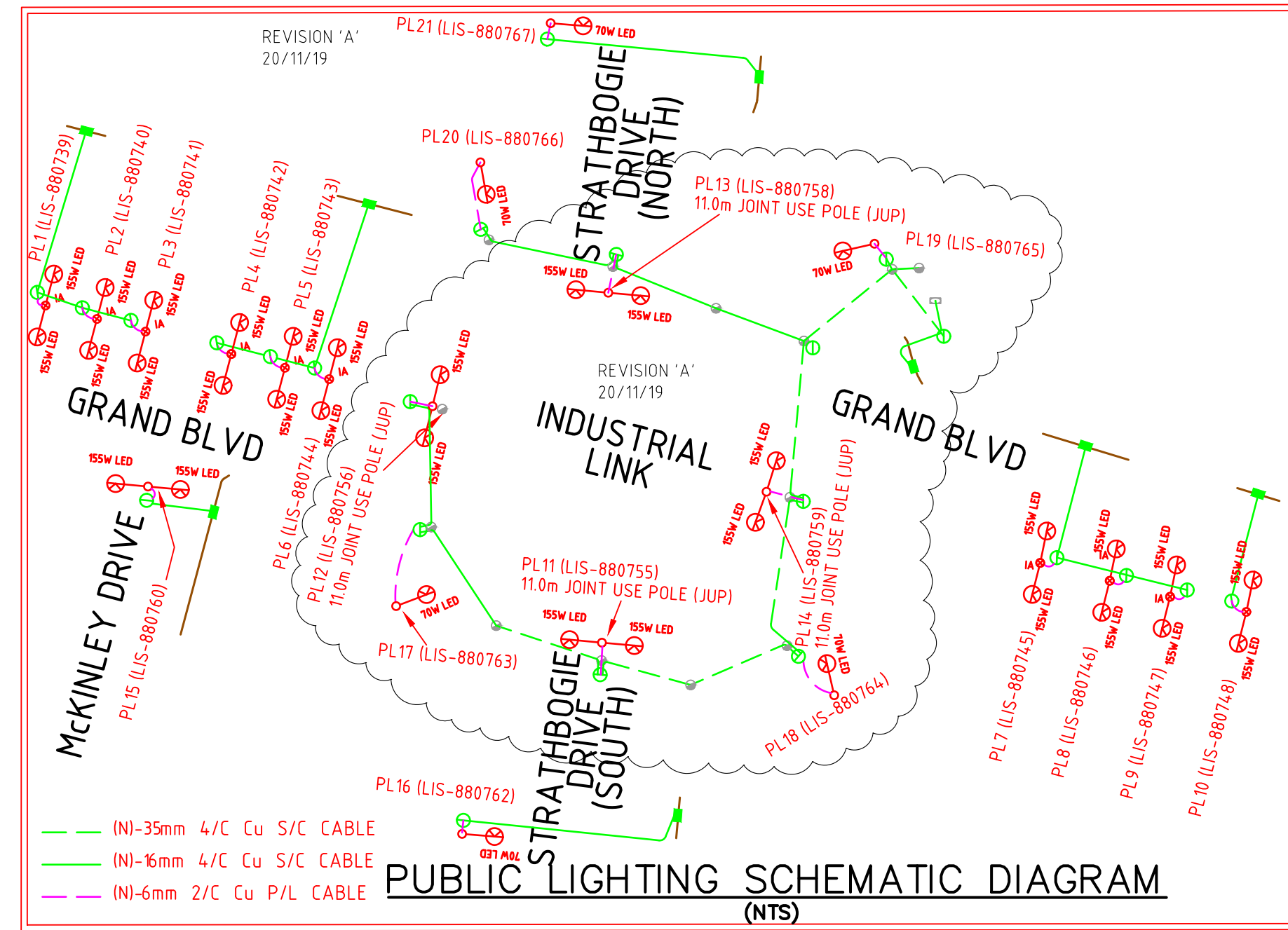

REMOTE LV TIE-IN WORKS
 WORKS TO BE TIED IN BY POWERCOR.
 (N) LV STRAIGHT JOINT (GS421) AT CLARA/GRAND INTERSECTION REFER TO PCA40/5114566/1-2

HV BENDING
 ALL HV CABLES TO MAINTAIN MIN 200.0mm BENDING RADIUS AS PER POWERCOR REQUIREMENT ALL HV CONDUIT BENDS TO BE 2.5m RADIUS

CONSTRUCTION CHANGES
 PROJECT MANAGER MUST BE NOTIFIED OF ANY CHANGE TO DESIGN DURING CONSTRUCTION. CHANGES MUST BE DETAILED.

RECOVERABLE WORKS
 UPDATE LV LABELS AT (E) "SIERRA - CLARA" KIOSK REFER TO PCA40/5114570/2

DETAILING
 TRENCH SHOULD NOT BE SAND AND SLAB BEFORE ELECTRICAL ASSETS DETAILS HAVE BEEN COLLECTED

PUBLIC LIGHTING SCHEDULE				PUBLIC LIGHTING SCHEDULE				PUBLIC LIGHTING SCHEDULE			
FOR PL POLE Nos:	PL1-PL10	FOR PL POLE Nos:	PL11 - PL14 / PL15	FOR PL POLE Nos:	PL16-21	FOR PL POLE Nos:	PL16-21	FOR PL POLE Nos:	PL16-21	FOR PL POLE Nos:	PL16-21
LANTERN:	STANDARD	LANTERN:	STANDARD	LANTERN:	STANDARD	LANTERN:	STANDARD	LANTERN:	STANDARD	LANTERN:	STANDARD
WATTAGE & TYPE	155W LED SYLVANIA PL9A05L155 12.5m	WATTAGE & TYPE	155W LED SYLVANIA PL9A05L155 12.5m	WATTAGE & TYPE	155W LED SYLVANIA PL9A05L155 12.5m	WATTAGE & TYPE	155W LED SYLVANIA PL9A05L155 12.5m	WATTAGE & TYPE	155W LED SYLVANIA PL9A05L155 12.5m	WATTAGE & TYPE	155W LED SYLVANIA PL9A05L155 12.5m
MODEL & CAT No	SAFEROADS SAFE 110 11.0m/1A	MODEL & CAT No	SAFEROADS SAFE 110 11.0m/1A	MODEL & CAT No	SAFEROADS SAFE 110 11.0m/1A	MODEL & CAT No	SAFEROADS SAFE 110 11.0m/1A	MODEL & CAT No	SAFEROADS SAFE 110 11.0m/1A	MODEL & CAT No	SAFEROADS SAFE 110 11.0m/1A
MOUNTING HEIGHT	12.5m	MOUNTING HEIGHT	12.5m	MOUNTING HEIGHT	12.5m	MOUNTING HEIGHT	12.5m	MOUNTING HEIGHT	12.5m	MOUNTING HEIGHT	12.5m
COLOUR	STANDARD	COLOUR	STANDARD	COLOUR	STANDARD	COLOUR	STANDARD	COLOUR	STANDARD	COLOUR	STANDARD
POLE:	STANDARD	POLE:	VICROADS	POLE:	VICROADS	POLE:	VICROADS	POLE:	VICROADS	POLE:	VICROADS
MANUFACTURER	SAFEROADS	MANUFACTURER	SAFEROADS	MANUFACTURER	SAFEROADS	MANUFACTURER	SAFEROADS	MANUFACTURER	SAFEROADS	MANUFACTURER	SAFEROADS
TYPE	SAFE 110	TYPE	SAFE 110	TYPE	SAFE 110	TYPE	SAFE 110	TYPE	SAFE 110	TYPE	SAFE 110
LENGTH & STRENGTH	11.0m/1A	LENGTH & STRENGTH	11.0m/1A	LENGTH & STRENGTH	11.0m/1A	LENGTH & STRENGTH	11.0m/1A	LENGTH & STRENGTH	11.0m/1A	LENGTH & STRENGTH	11.0m/1A
COLOUR	STANDARD GALV	COLOUR	STANDARD GALV	COLOUR	STANDARD GALV	COLOUR	STANDARD GALV	COLOUR	STANDARD GALV	COLOUR	STANDARD GALV
BRACKET:	STANDARD	BRACKET:	STANDARD	BRACKET:	STANDARD	BRACKET:	STANDARD	BRACKET:	STANDARD	BRACKET:	STANDARD
MANUFACTURER	SAFEROADS	MANUFACTURER	SAFEROADS	MANUFACTURER	SAFEROADS	MANUFACTURER	SAFEROADS	MANUFACTURER	SAFEROADS	MANUFACTURER	SAFEROADS
TYPE	DOUBLE OUTREACH SPIGOT	TYPE	DOUBLE OUTREACH SPIGOT	TYPE	DOUBLE OUTREACH SPIGOT	TYPE	DOUBLE OUTREACH SPIGOT	TYPE	DOUBLE OUTREACH SPIGOT	TYPE	DOUBLE OUTREACH SPIGOT
LENGTH	4.5m/4.5m	LENGTH	4.5m/4.5m	LENGTH	4.5m/4.5m	LENGTH	4.5m/4.5m	LENGTH	4.5m/4.5m	LENGTH	4.5m/4.5m
COLOUR	STANDARD GALV	COLOUR	STANDARD GALV	COLOUR	STANDARD GALV	COLOUR	STANDARD GALV	COLOUR	STANDARD GALV	COLOUR	STANDARD GALV
COUNCIL:	MELTON COUNCIL	COUNCIL:	MELTON COUNCIL	COUNCIL:	MELTON COUNCIL	COUNCIL:	MELTON COUNCIL	COUNCIL:	MELTON COUNCIL	COUNCIL:	MELTON COUNCIL

SERVICE LOCATIONS								
STREET NAME	GAS		WATER		NBN		ELECTRICITY	
	OFFSET	SIDE	OFFSET	SIDE	OFFSET	SIDE	OFFSET	SIDE
GRAND BOULEVARD	2.30m	SOUTH	2.80m	SOUTH	1.85m	NORTH	3.40m	NORTH
MCKINLEY DRIVE	2.25m	WEST	2.70m	WEST	1.85m	EAST	2.75m	EAST
STRATHBOGIE DRIVE (SOUTH)	2.25m	WEST	2.70m	WEST	1.85m	EAST	2.60m	EAST
STRATHBOGIE DRIVE (NORTH)	2.25m	WEST	2.70m	WEST	1.85m	EAST	2.60m	EAST

DEEP TRENCHING
 DUE TO SAFETY CONCERNS, TRENCHES FOR CONDUIT INSTALLATION SHOULD NOT BE DUG DEEPER THAN 1.5m.
 IF TRENCHES NEED TO BE DUG DEEPER THAN 1.5m, PRIOR APPROVAL MUST BE GRANTED BY PM2 AND POWERCOR.
 ALL CONDUIT ENDS ARE TO BE A MAXIMUM DEPTH OF 12m.
 20/11/19

PL NOTES
 ALL PL POLES TO BE INSTALLED 10m FROM B.O.K UNLESS STATED OTHERWISE.
 POLE AND LANTERN TYPE, WATTAGE AND MANUFACTURER MUST MATCH LIGHTING SCHEDULE. ANY DEVIATION MUST BE APPROVED BY COUNCIL AND POWERCOR.
 ALL LANTERNS TO BE ORDERED WITH 7 PIN NEMA BASE.
 PL POLES TO MAINTAIN 0.5m CLEARANCE FROM ALL PATHS, PRAM CROSSINGS AND CROSS OVERS.
 20/11/19

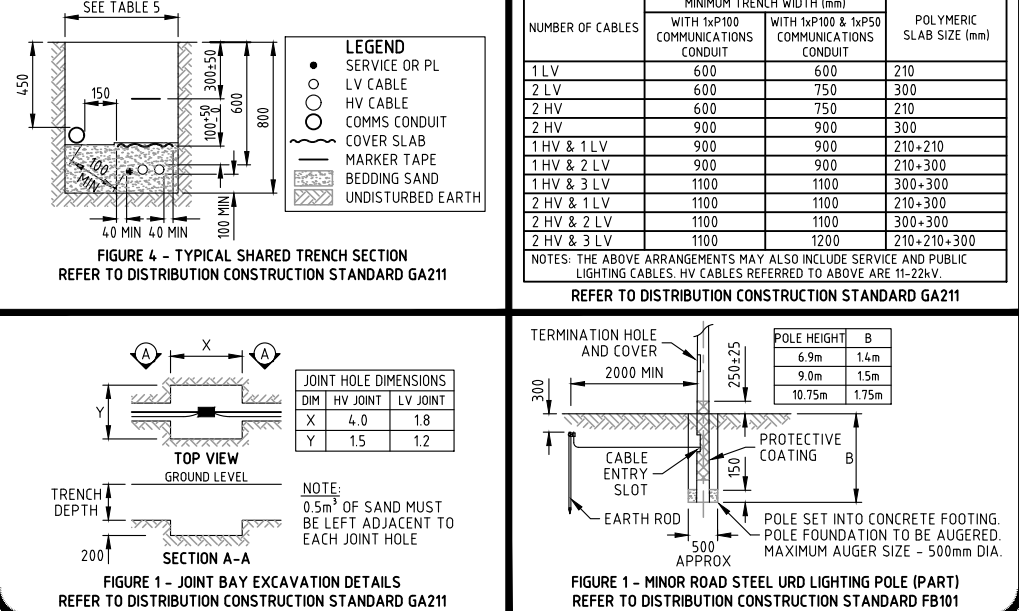
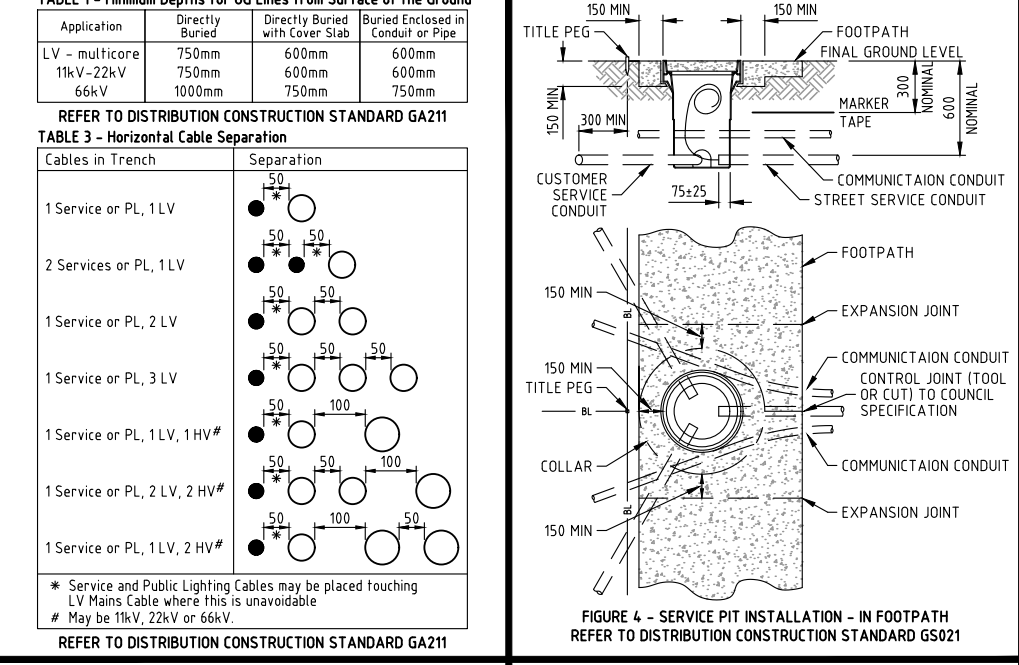
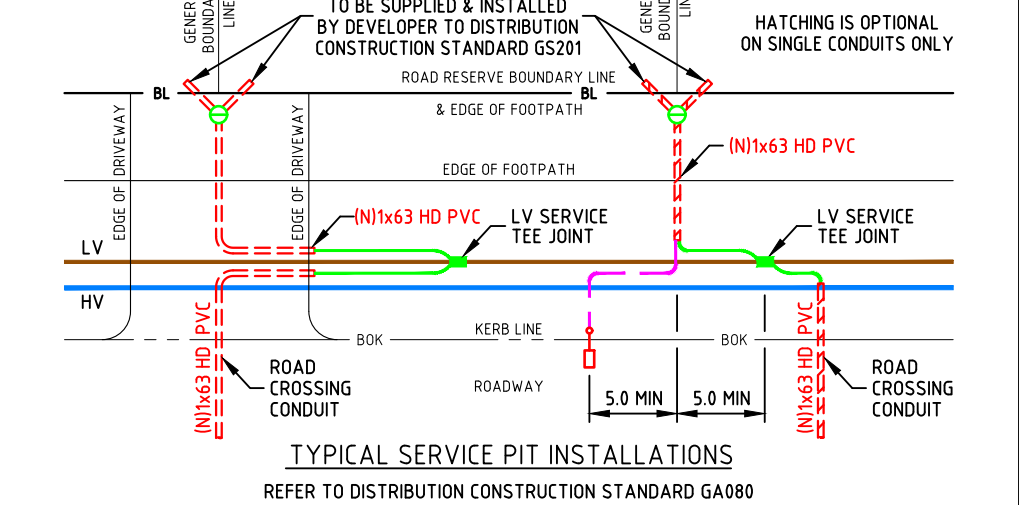
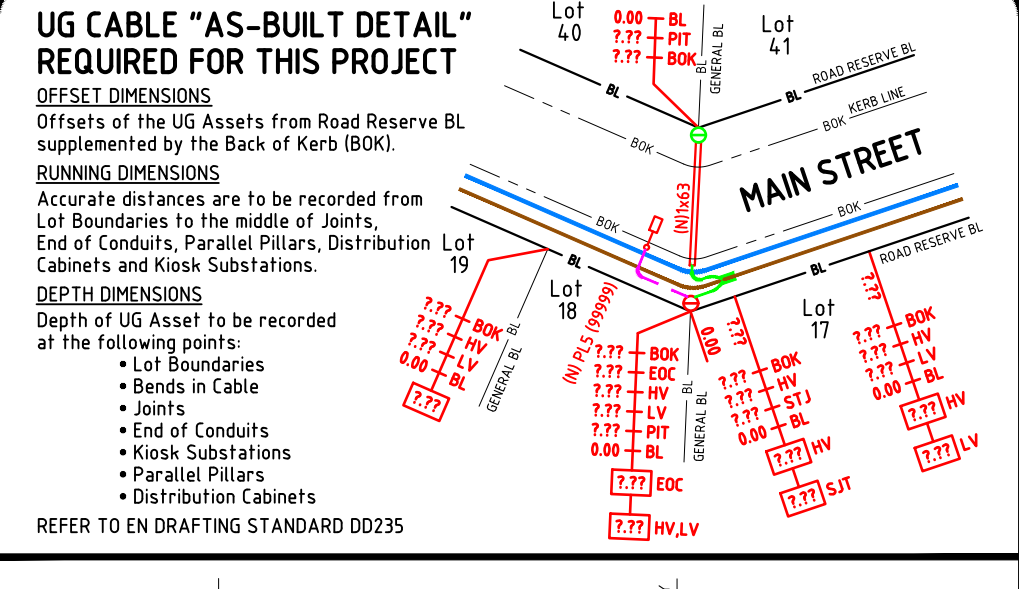
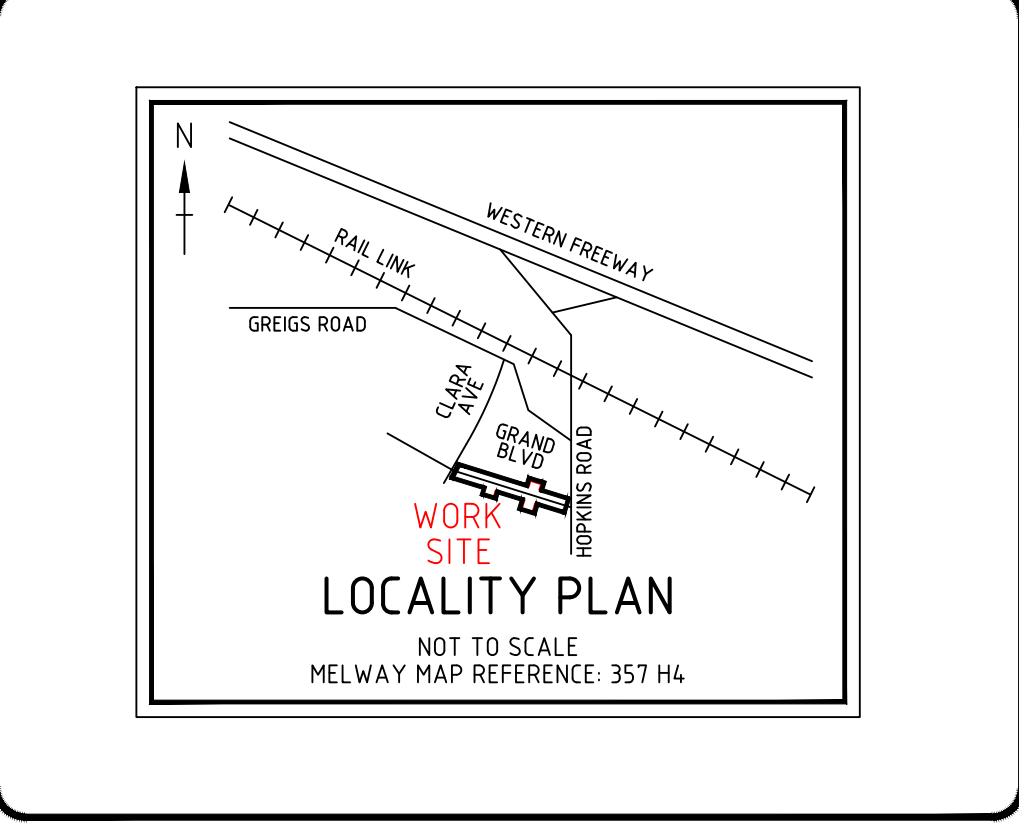

PROJECT NUMBER	S114570
ROAD DIRECTORY	MELWAY REF 357 H4
GIS SYSTEM PLAN	MAP 220-CL
PROJECTION	MGA Zone 55
FEEDER/SWITCHING ZONE	MLN021 - SW23092545
DEVELOPER/NUMBER OF LOTS	STOCKLAND 7 PUBLIC LIGHTING
MUNICIPAL COUNCIL	MELTON COUNCIL

CLEARANCE OF ELECTRICAL CABLES & CONDUITS (UP TO 22kV) TO OTHER UTILITY ASSETS AND STRUCTURES - AUDITING GUIDELINE

MINIMUM HORIZONTAL OR PARALLEL CLEARANCE (OFFSET) TO CABLE OR CONDUIT			MINIMUM VERTICAL & CROSSING CLEARANCE ¹
WATER	200 TO 375mm WATER MAIN ³	> 200 TO 375mm WATER MAIN ³	
500mm - SEPARATE TRENCH	1000mm - SEPARATE TRENCH	1000mm - SEPARATE TRENCH	225mm
300mm - SHARED TRENCH	600mm - SHARED TRENCH	600mm - SHARED TRENCH	
GAS	50mm GAS PIPE: 300mm	> 50mm GAS PIPE: 500mm	150mm
COMMUNICATIONS	100mm TO LV CABLE/CONDUIT; 300mm TO HV CABLE/CONDUIT	50mm TO LV COVER SLAB; 250mm TO HV COVER SLAB	100mm LV, 300mm HV
STREET LIGHT POLES	300mm TO ALL OTHER ASSETS		N/A
STORM WATER PIPE	300mm		100mm LV, 300mm HV
OTHER ASSETS/ STRUCTURES	100mm LV, 300mm HV		100mm LV, 300mm HV

- NOTES:**
- ALL SPECIFIED DISTANCES ARE THE MINIMUM REQUIREMENT MEASURED BETWEEN ASSET EDGES OR FACES
 - SPECIFIED CLEARANCE APPLIES TO BOTH LV AND HV ELECTRICAL ASSETS WHERE NOT NOTED
 - ANY VARIATIONS TO THESE MINIMUM CLEARANCES MUST HAVE PRIOR WRITTEN APPROVAL FROM THE CIPPOWER/POWERCOR RESPONSIBLE OFFICER AND/OR MANAGER TECHNICAL STANDARDS
 - CROSSING CLEARANCES DOCUMENTED ARE TO THE ELECTRICAL CABLE OR CONDUIT. THE MINIMUM CROSSING CLEARANCE ABOVE CABLE COVER SLABS SHALL BE 50mm TO LV & 250mm TO HV COVER SLABS FOR COMMUNICATION CABLES, 175mm TO WATER, 100mm TO GAS ETC.
 - LARGER PIPE SIZES MAY REQUIRE ADDITIONAL CLEARANCES - CONSULT RELEVANT WATER AUTHORITY
 - INCLUDES PROPERTY LEAD-IN CONDUITS
 - INCLUDES STORM WATER PITS, SEWER INSPECTION POINT SHAFTS ETC. (ALL CABLE JOINTS MINIMUM 300mm CLEARANCE)

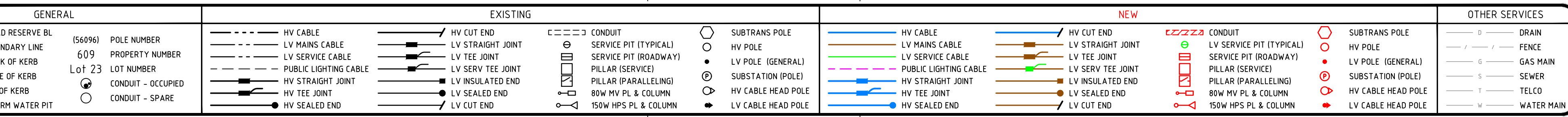

OTHER SERVICES
BRAN
FENCE
GAZ MAN
SEWER
TELCO
WATER MAIN

SCALE 1:500

REVISION 20/11/19 OFFSET IN GRAND BVD CHANGED. CONDUITS REVISED TO SUIT AND FUTURE ROAD RENAMED STRATHBOGIE DRIVE BY PLAN B

DRAWING NUMBER **PCA40 5114570** 1 A SHEET 1 OF 2

GRAND BOULEVARD, INDUSTRIAL LINK UG CONSTRUCTION PLAN - URD MOUNT ATKINSON ESTATE DETAIL DESIGN

DRAWN AT (BFD) 22/11/18	S.FLANAGAN	DESIGNED AT (BFD) 22/11/18	S.FLANAGAN	DESIGN APPROVAL 25/03/19	M.WILLIAMS	PROJECT MANAGER 25/03/19
-------------------------	------------	----------------------------	------------	--------------------------	------------	--------------------------

DEVELOPER NOTE

HV CABLE PULL FROM (B) TO (C) NOT ALLOWED

HV CABLE PULL FROM (C) TO (D) IS ONLY ALLOWED WITH LUBRICANT

HV CABLE PULL FROM (D) TO (E) IS ONLY ALLOWED WITH LUBRICANT

HV CABLE PULL FROM (E) TO (F) IS ONLY ALLOWED WITH LUBRICANT

HV CABLE PULL FROM (F) TO (G) IS ONLY ALLOWED WITH LUBRICANT

HV CABLE PULL FROM (G) TO (H) IS ONLY ALLOWED WITH LUBRICANT

HV TIE-IN WORKS

WORKS TO BE TIED IN BY POWERCOR

(N) HV STRAIGHT JOINT (GS421) AT CLARA AVENUE SOUTH OF CLARA/GRAND INTERSECTION REFER TO MT ATKINSON STAGE 1 DWG NO. PCA40/5114572/1

PL NOTES

ALL P/L POLES TO BE INSTALLED 1.0m FROM B.O.K UNLESS STATED OTHERWISE

POLE AND LANTERN TYPE, WATTAGE AND MANUFACTURER MUST MATCH LIGHTING SCHEDULE. ANY DEVIATION MUST BE APPROVED BY COUNCIL AND POWERCOR.

ALL LANTERNS TO BE ORDERED WITH 7 PIN NEMA BASE

P/L POLES TO MAINTAIN 0.5m CLEARANCE FROM ALL PATHS, PRAM CROSSINGS AND CROSS OVERS.

REMOTE LV TIE-IN WORKS

WORKS TO BE TIED IN BY POWERCOR

(N) LV STRAIGHT JOINT (GS421) AT GRAND BLVD REFER TO PCA40/5114570/1

HV BENDING

ALL HV CABLES TO MAINTAIN MIN 200mm BENDING RADIUS AS PER POWERCOR REQUIREMENT

ALL HV CONDUIT BENDS TO BE 2.5m RADIUS

DEEP TRENCHING

DOE TO SAFETY CONCERNS, TRENCHES FOR CONDUIT INSTALLATION SHOULD NOT BE DUG DEEPER THAN 15m.

IF TRENCHES NEED TO BE DUG DEEPER THAN 15m, PRIOR APPROVAL MUST BE GRANTED BY PM2 AND POWERCOR

ALL CONDUITS AT A DEPTH OF 1.2m OR GREATER ARE TO BE EXTENDED AND ELEVATED UNTIL THE CONDUIT END IS AT 0.8m DEEP

CONSTRUCTION CHANGES

PROJECT MANAGER MUST BE NOTIFIED OF ANY CHANGE TO DESIGN DURING CONSTRUCTION. CHANGES MUST BE DETAILED.

DETAILING

TRENCH SHOULD NOT BE SAND AND SLAB BEFORE ELECTRICAL ASSETS DETAILS HAVE BEEN COLLECTED.

RECOVERABLE WORKS

UPDATE LV LABELS AT (E) "SIERRA - CLARA" KIOSK REFER TO PCA40/5114570/2

PUBLIC LIGHTING SCHEDULE		PUBLIC LIGHTING SCHEDULE		PUBLIC LIGHTING SCHEDULE		PUBLIC LIGHTING SCHEDULE	
FOR P/L POLE Nos:	PL1	FOR P/L POLE Nos:	PL3 - PL4	FOR P/L POLE Nos:	PL5	FOR P/L POLE Nos:	PL6, PL12
LANTERN:	STANDARD	LANTERN:	STANDARD	LANTERN:	STANDARD	LANTERN:	STANDARD
WATTAGE & TYPE:	155W LED SYLVANIA PL99A05L155	WATTAGE & TYPE:	155W LED SYLVANIA PL99A05L155	WATTAGE & TYPE:	155W LED SYLVANIA PL99A05L155	WATTAGE & TYPE:	155W LED SYLVANIA PL99A05L155
MANUFACTURE:	STANDARD	MANUFACTURE:	STANDARD	MANUFACTURE:	STANDARD	MANUFACTURE:	STANDARD
MODEL & CAT No:	STANDARD	MODEL & CAT No:	STANDARD	MODEL & CAT No:	STANDARD	MODEL & CAT No:	STANDARD
MOUNTING HEIGHT:	12.5m	MOUNTING HEIGHT:	12.5m	MOUNTING HEIGHT:	12.5m	MOUNTING HEIGHT:	12.5m
COLOUR:	STANDARD	COLOUR:	STANDARD	COLOUR:	STANDARD	COLOUR:	STANDARD
POLE:	STANDARD	POLE:	VICROADS	POLE:	VICROADS	POLE:	STANDARD
MANUFACTURER:	SAFEROADS	MANUFACTURER:	SAFEROADS	MANUFACTURER:	SAFEROADS	MANUFACTURER:	SAFEROADS
MODEL & CAT No:	SAFE 110	MODEL & CAT No:	SAFE 110	MODEL & CAT No:	SAFE 110	MODEL & CAT No:	SAFE 110
LENGTH & STRENGTH:	11.0m/A	LENGTH & STRENGTH:	11.0m/A	LENGTH & STRENGTH:	11.0m/A	LENGTH & STRENGTH:	11.0m/A
COLOUR:	STANDARD GALV	COLOUR:	STANDARD GALV	COLOUR:	STANDARD GALV	COLOUR:	STANDARD GALV
BRACKET:	STANDARD	BRACKET:	STANDARD	BRACKET:	STANDARD	BRACKET:	STANDARD
MANUFACTURER:	SAFEROADS	MANUFACTURER:	SAFEROADS	MANUFACTURER:	SAFEROADS	MANUFACTURER:	SAFEROADS
TYPE:	DOUBLE OUTREACH SPIGOT	TYPE:	DOUBLE OUTREACH SPIGOT	TYPE:	DOUBLE OUTREACH SPIGOT	TYPE:	DOUBLE OUTREACH SPIGOT
LENGTH:	4.5m/4.5m	LENGTH:	4.5m/4.5m	LENGTH:	4.5m/4.5m	LENGTH:	4.5m/4.5m
COLOUR:	STANDARD GALV	COLOUR:	STANDARD GALV	COLOUR:	STANDARD GALV	COLOUR:	STANDARD GALV
COUNCIL:	MELTON COUNCIL	COUNCIL:	MELTON COUNCIL	COUNCIL:	MELTON COUNCIL	COUNCIL:	MELTON COUNCIL

PUBLIC LIGHTING SCHEDULE

FOR P/L POLE Nos: PL2

LANTERN: STANDARD

WATTAGE & TYPE: 155W LED SYLVANIA PL99A05L155

MANUFACTURE: STANDARD

MODEL & CAT No: STANDARD

MOUNTING HEIGHT: 12.5m

COLOUR: STANDARD

POLE: STANDARD

MANUFACTURER: SAFEROADS

MODEL & CAT No: SAFE 110

LENGTH & STRENGTH: 11.0m/A

COLOUR: STANDARD GALV

BRACKET: STANDARD

MANUFACTURER: SAFEROADS

TYPE: DOUBLE OUTREACH SPIGOT

LENGTH: 3.0m/3.0m

COLOUR: STANDARD GALV

COUNCIL: MELTON COUNCIL

REVISION 'A': 14/08/19

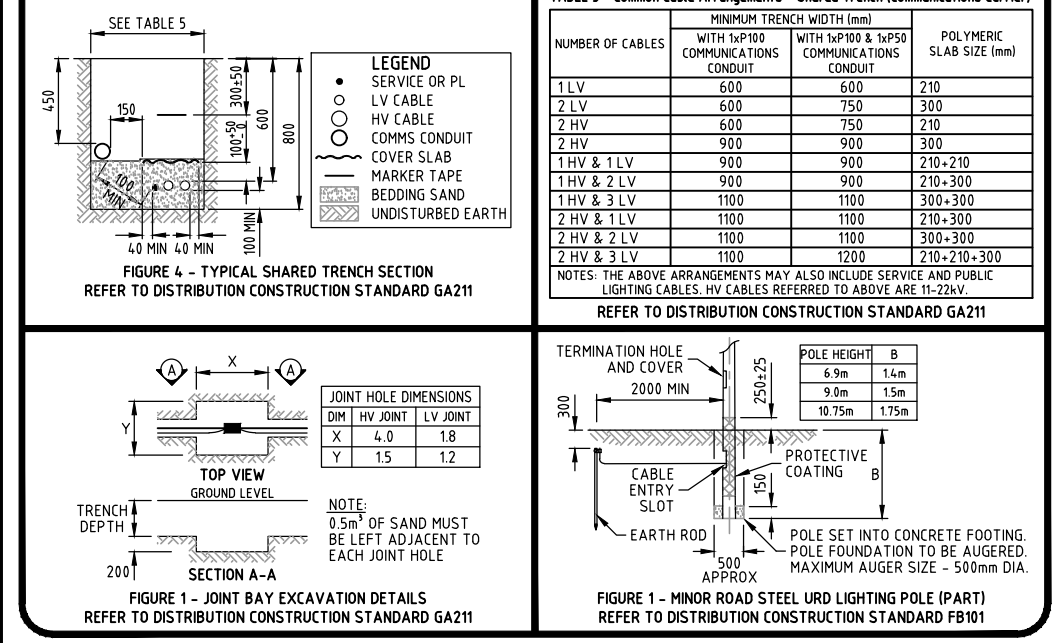
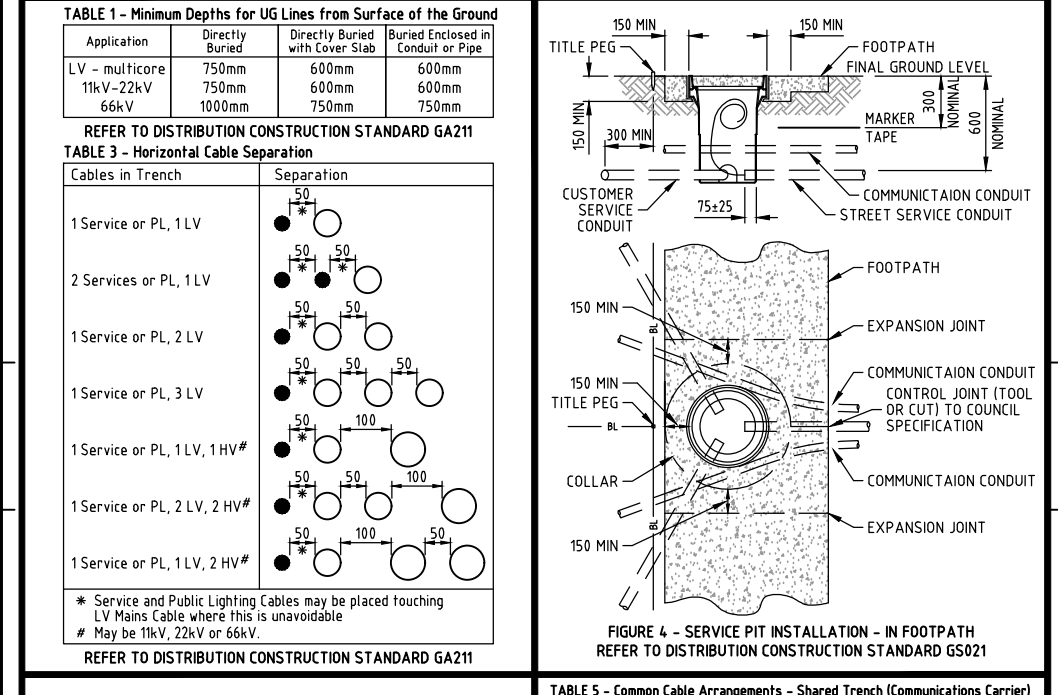
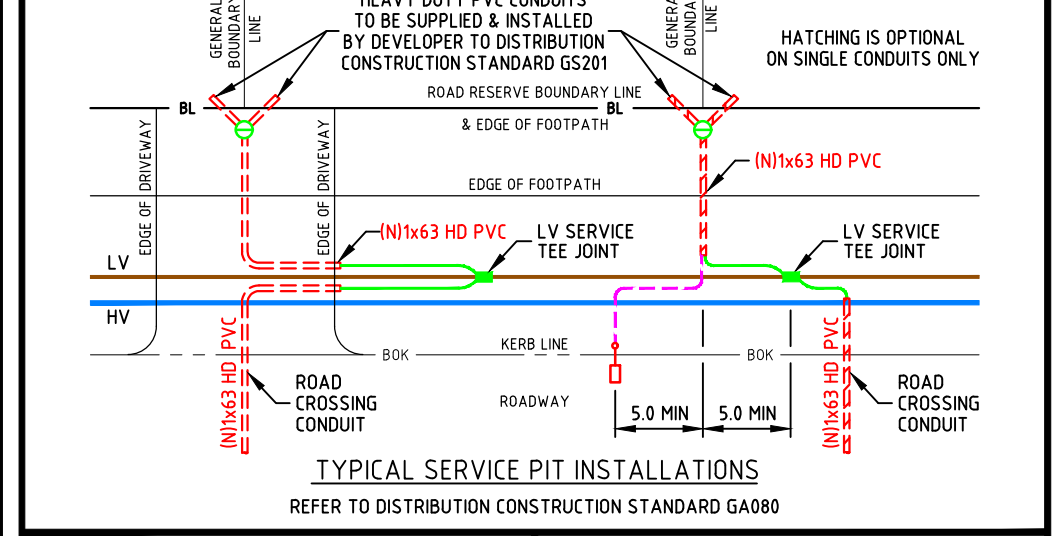
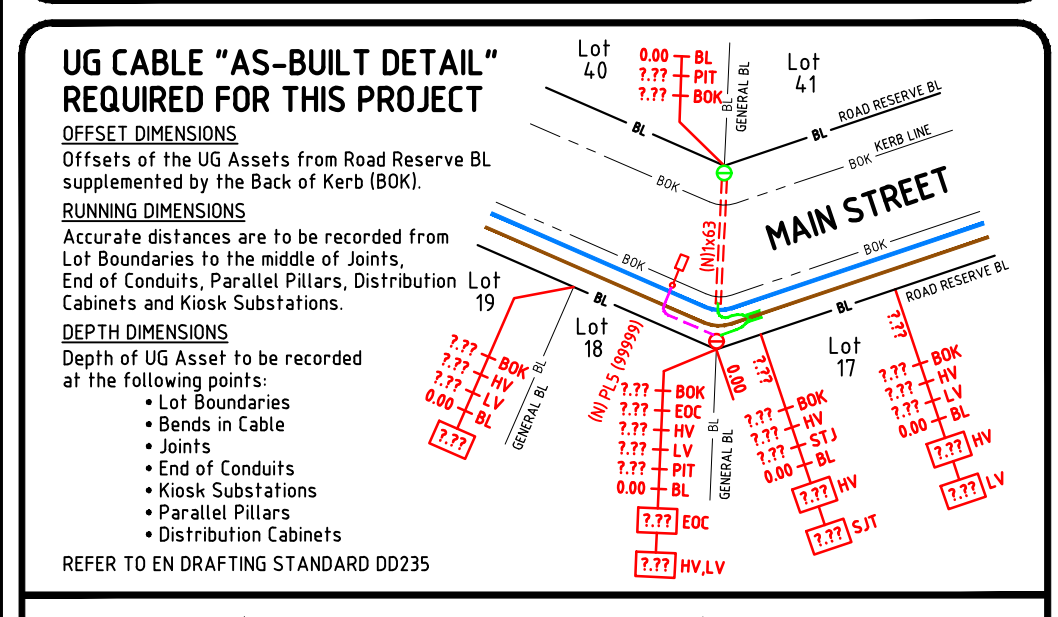
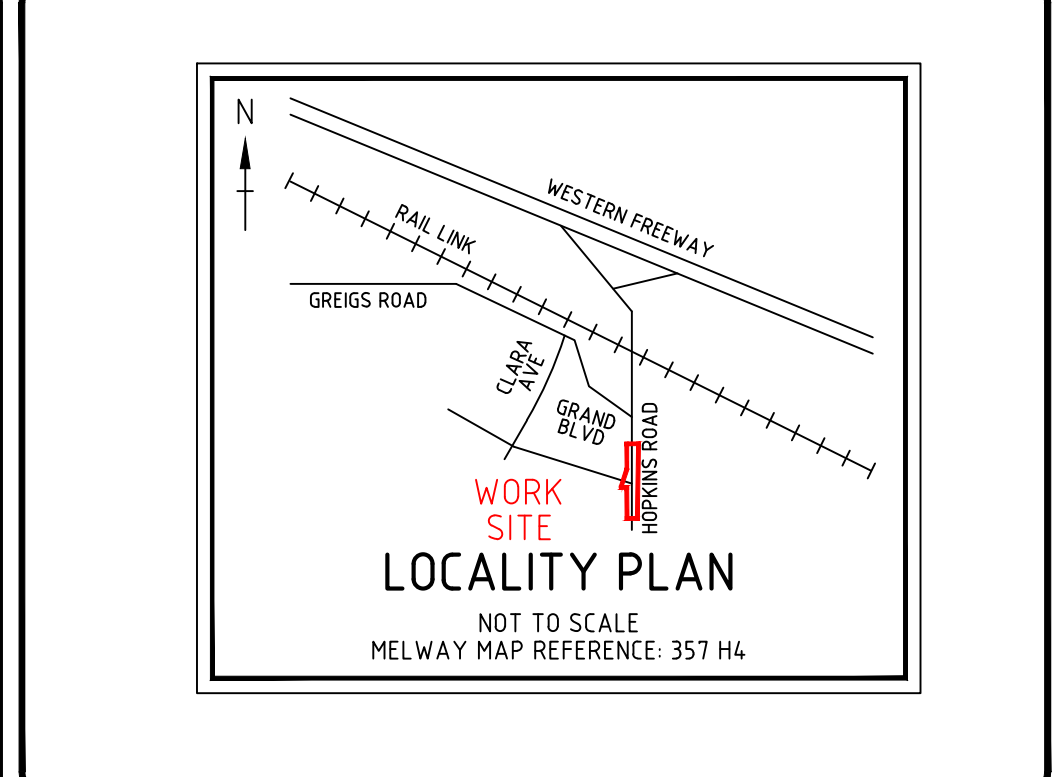
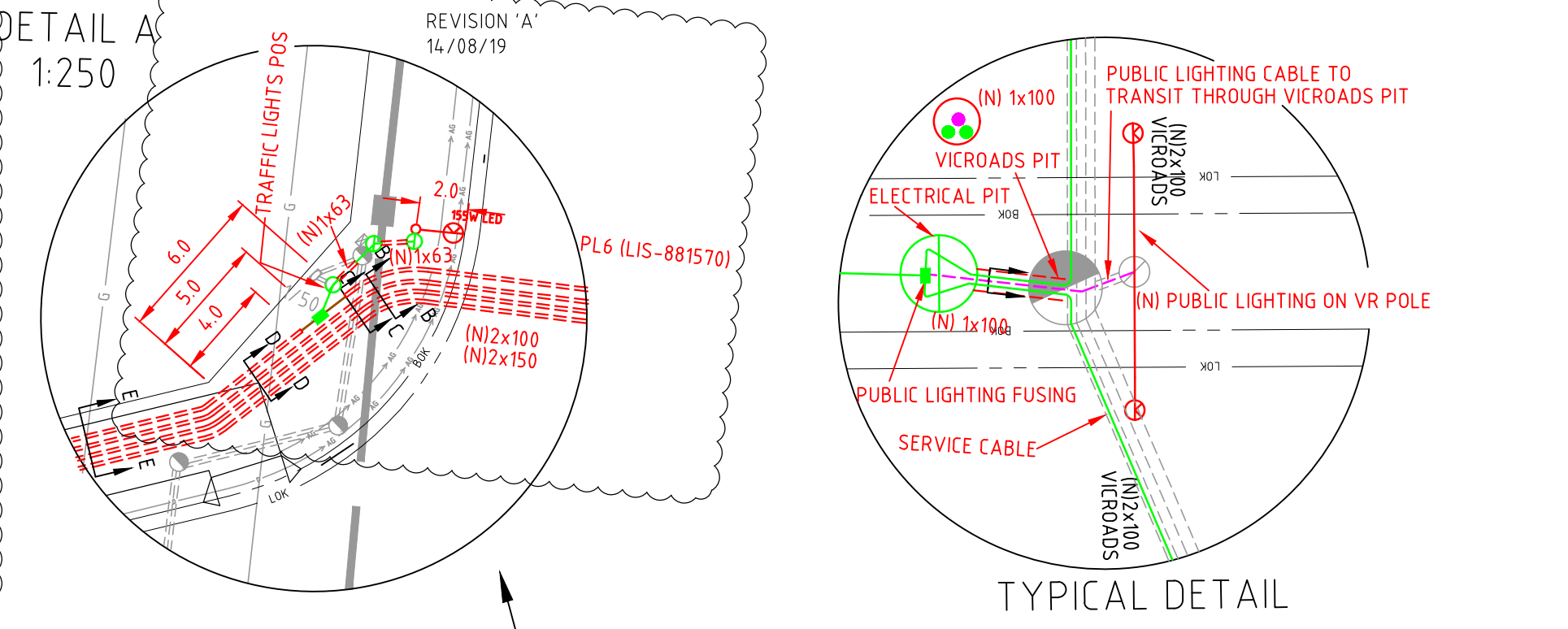

PROJECT NUMBER	S114572
ROAD DIRECTORY	MELWAY REF 357 J4
GIS SYSTEM PLAN	MAP 220.CC
PROJECTION	MGA Zone 55
FEEDER/SWITCHING ZONE	MLN021 - SWZ-3092545
DEVELOPER/NUMBER OF LOTS	STOCKLAND / PUBLIC LIGHTING
MUNICIPAL COUNCIL	MELTON COUNCIL

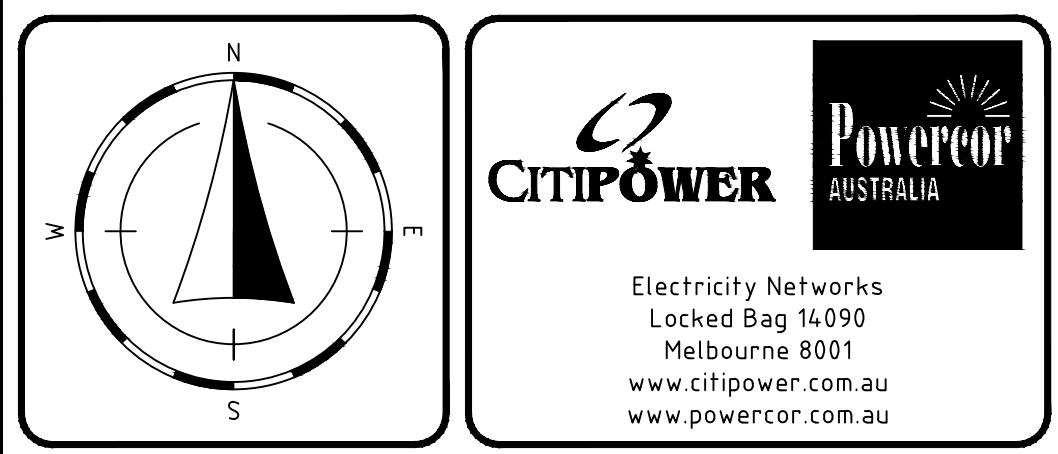

REVISION	14/08/19	PL6 (LIS-881570) AND TRAFFIC SIGNALS POINT OF SUPPLY RELOCATED BY PLAN B	SK PD
DRAWING NUMBER	PCA40 5114572	01 B	SHEET 1 OF 4
GRAND/HOPKINS INTERSECTION - TRUGANINA UG CONSTRUCTION PLAN - URD MT. ATKINSON ESTATE DETAIL DESIGN			
DRAWN	BFD (AT)	DRAFTING DESIGNER	S.FLANAGAN
DESIGNED	BFD (AT)	DESIGN APPROVAL	S.FLANAGAN
DATE	26/10/18	DATE	11/04/19
PROJECT MANAGER	M.WILLIAMS	DATE	11/04/19

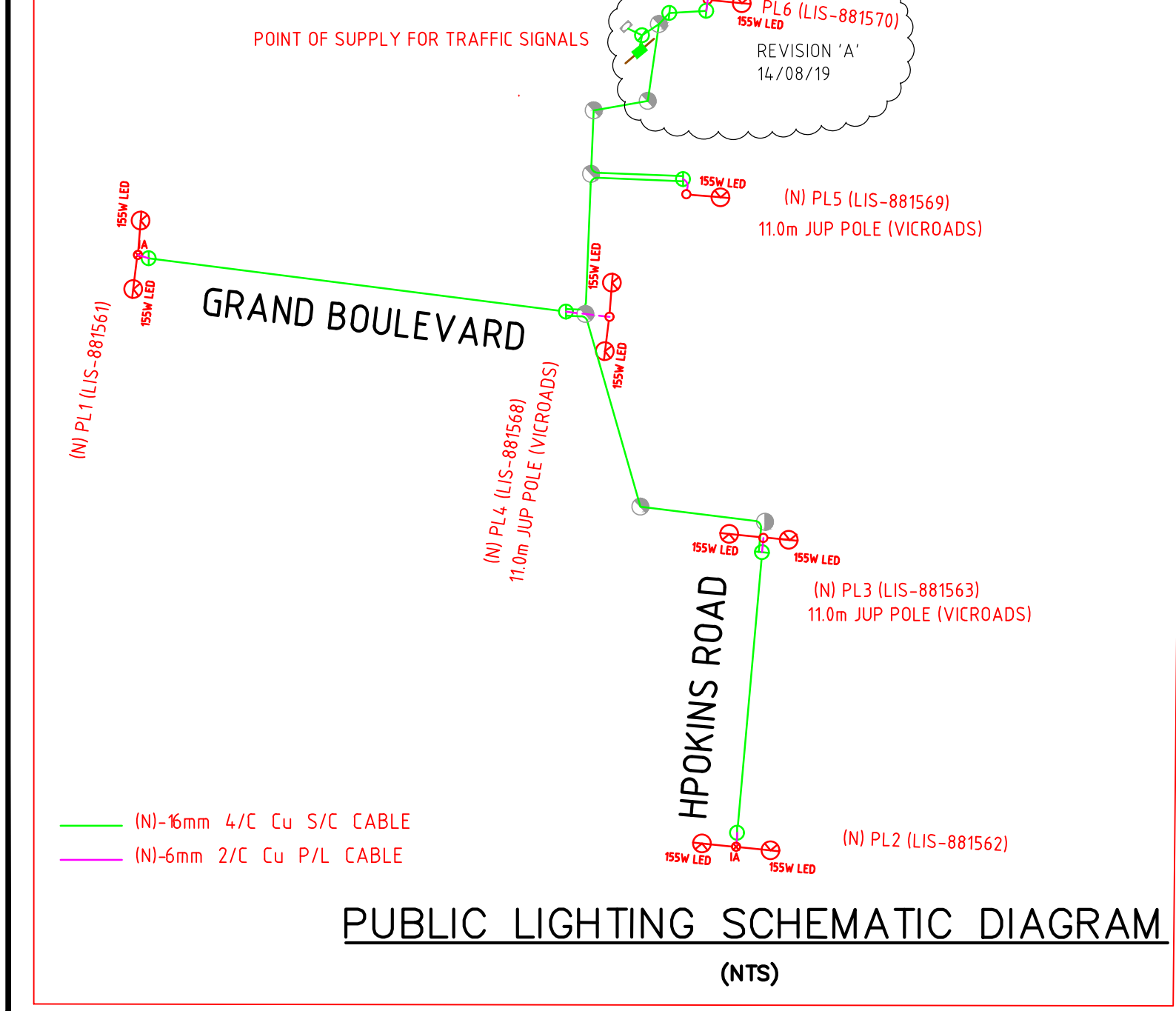
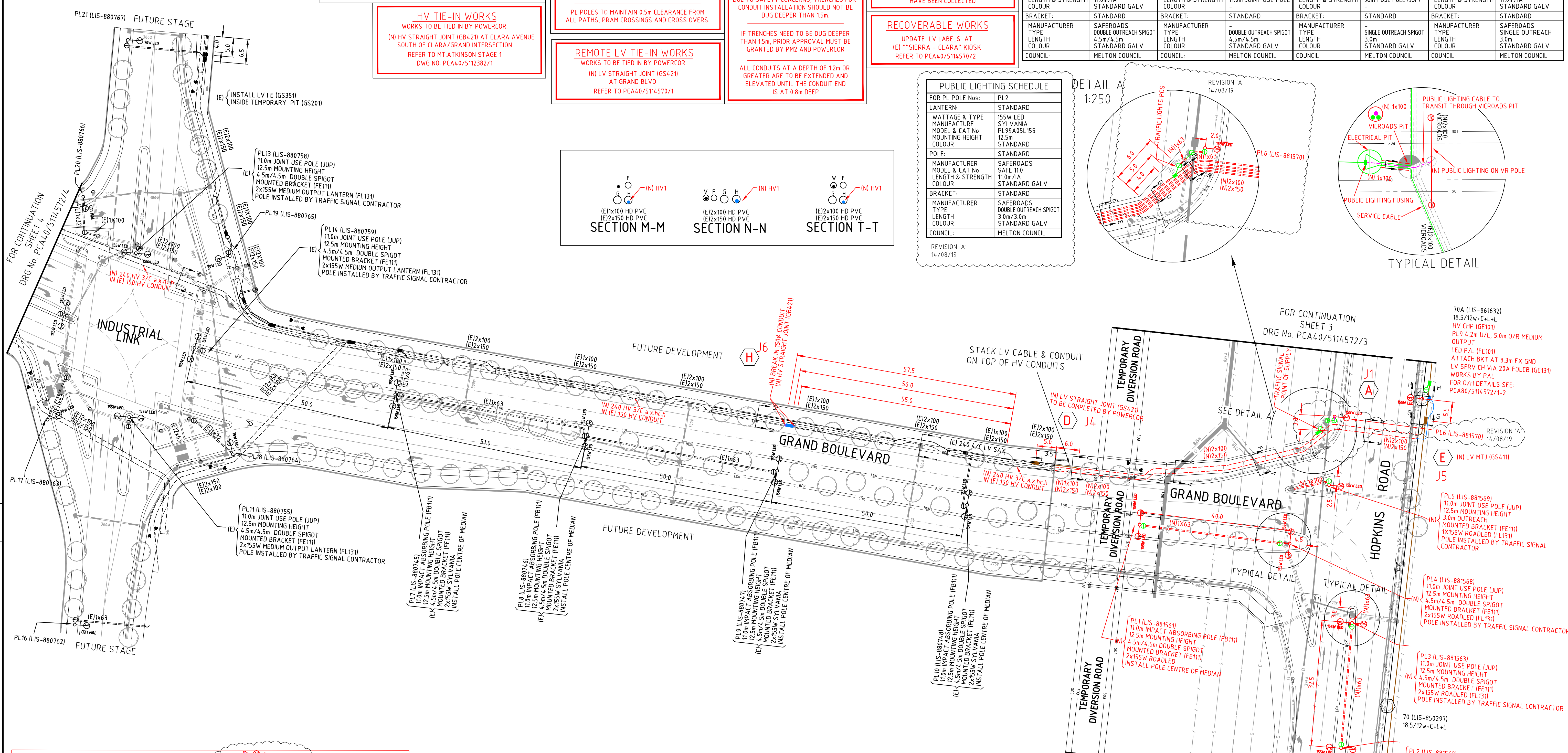

CLEARANCE OF ELECTRICAL CABLES & CONDUITS (UP TO 22kV) TO OTHER UTILITY ASSETS AND STRUCTURES - ADJUTING GUIDELINE

	MINIMUM HORIZONTAL OR PARALLEL CLEARANCE (OFFSET) TO CABLE OR CONDUIT	MINIMUM VERTICAL & CROSSING CLEARANCE ¹
WATER	200 WATER MAIN: 500mm - SEPARATE TRENCH 300mm - SHARED TRENCH > 200 TO 375mm WATER MAIN ² : 1000mm - SEPARATE TRENCH 600mm - SHARED TRENCH	225mm
GAS	50mm GAS PIPE: 300mm > 50mm GAS PIPE: 500mm	150mm
COMMUNICATIONS ⁶	100mm TO LV CABLE/CONDUIT, 300mm TO HV CABLE/CONDUIT 50mm TO LV COVER SLAB, 250mm TO HV COVER SLAB	100mm LV, 300mm HV
STREET LIGHT POLES	300mm TO ALL OTHER ASSETS	N/A
STORM WATER PIPE	300mm	100mm LV, 300mm HV
OTHER ASSETS, STRUCTURES ⁷	100mm LV, 300mm HV	100mm LV, 300mm HV

- NOTES:
- ALL SPECIFIED DISTANCES ARE THE MINIMUM REQUIREMENT MEASURED BETWEEN ASSET EDGES OR FACES
 - SPECIFIED CLEARANCE APPLIES TO BOTH LV AND HV ELECTRICAL ASSETS WHERE NOT NOTED
 - ANY VARIATIONS TO THESE MINIMUM CLEARANCES MUST HAVE PRIOR WRITTEN APPROVAL FROM THE CHIEF OFFICER POWERCOR RESPONSIBLE OFFICER AND/OR MANAGER TECHNICAL STANDARDS
 - CROSSING CLEARANCES DOCUMENTED ARE TO THE ELECTRICAL CABLE OR CONDUIT. THE MINIMUM CROSSING CLEARANCE ABOVE CABLE COVER SLABS SHALL BE 50mm TO LV & 250mm TO HV COVER SLABS FOR COMMUNICATION CABLES, 175mm TO WATER, 100mm TO GAS ETC.
 - LARGER PIPE SIZES MAY REQUIRE ADDITIONAL CLEARANCES - CONSULT RELEVANT WATER AUTHORITY
 - INCLUDES PROPERTY LEAD-IN CONDUITS
 - INCLUDES STORM WATER PITS, SEWER INSPECTION POINT SHAFTS ETC. (ALL CABLE JOINTS MINIMUM 300mm CLEARANCE)

STREET NAME	GAS				WATER				NBN				ELECTRICITY			
	OFFSET	SIDE	OFFSET	SIDE	OFFSET	SIDE	OFFSET	SIDE	OFFSET	SIDE	OFFSET	SIDE	OFFSET	SIDE		
GRAND BOULEVARD	2.30m	SOUTH	2.80m	SOUTH	1.85m	NORTH	3.90m	NORTH								
HOPKINS ROAD	EXISTING	WEST	-	-	-	-	-	-	1.30m	EAST						

CABLE ID	LOCATION	DETAILS	LENGTH
HV MAINS CABLE:			
(N) HV1	FROM CHP (LIS881632) @ HOPKINS ROAD TO HV SJ @ EAST OF INDUSTRIAL LINK GRAND BLVD	240 3/C 22 a.x.h.c.h	210m
(N) HV2	FROM HV SJ @ EAST OF INDUSTRIAL LINK GRAND BLVD TO HV SJ @ WEST OF INDUSTRIAL LINK GRAND BLVD	240 3/C 22 a.x.h.c.h	275m
(N) HV3	FROM HV SJ @ WEST OF INDUSTRIAL LINK GRAND BLVD TO HV SJ @ SOUTH OF CLARA/GRAND INT, CLARA AV	240 3/C 22 a.x.h.c.h	350m
LV MAINS CABLE:			
(N) LV1	FROM SJ @ EAST END OF GRAND BLVD TO ST/J @ ADJ POLE 69 (LIS850296) HOPKINS ROAD	240 4c LV s.a.x.	275m
(N) LV2	FROM MT/J @ ADJ POLE 70A (LIS-861632) HOPKINS ROAD TO ST/J @ ADJ POLE 73 (LIS875187) HOPKINS ROAD	240 4c LV s.a.x.	250m
SERVICE CABLE:			
PL CABLE		16 4c LV c.x.	400m
		6 2c LV c.v.	160m

CABLE SCHEDULE

Table with 4 columns: CABLE ID, LOCATION, DETAILS, LENGTH. Lists various cable types like 22kV CABLE, LV MAINS CABLE, and SERVICE CABLE with their respective locations and lengths.

SERVICE LOCATIONS

Table with 8 columns: STREET NAME, GAS, WATER, NBN, ELECTRICITY. Lists service locations for various streets including KIRKPATRICK BOULEVARD, DOLOMITES DRIVE, and ELBRUS STREET.

CLEARANCE OF ELECTRICAL CABLES & CONDUITS (UP TO 22kV) TO OTHER UTILITY ASSETS AND STRUCTURES - AUDITING GUIDELINE

Table with 3 columns: MINIMUM HORIZONTAL OR PARALLEL CLEARANCE (OFFSET) TO CABLE OR CONDUIT, MINIMUM VERTICAL & CROSSING CLEARANCE. Lists clearance requirements for Water, Gas, Communications, Street Light Poles, Storm Water Pipes, and Other Assets/Structures.

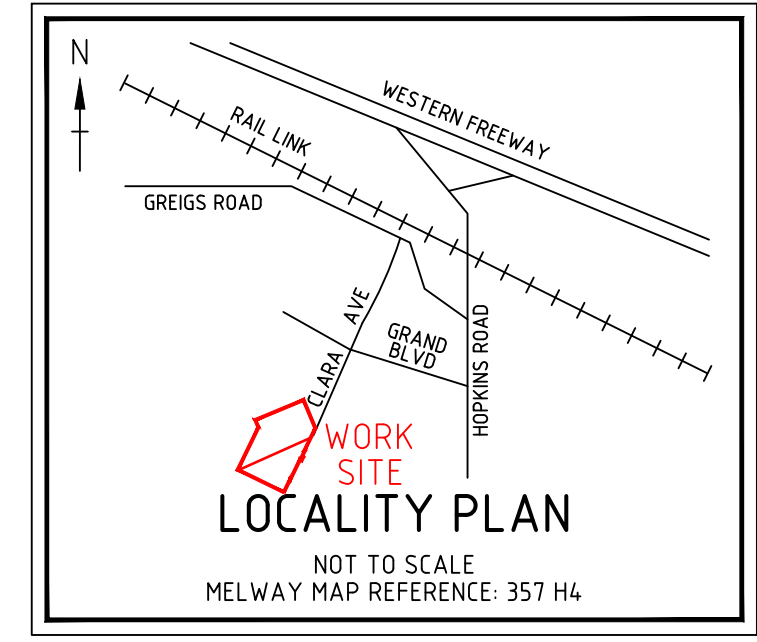

FOR CONTINUATION REFER TO DRG No. PCA40/5114649/2 MT ATKINSON ESTATE - STAGE 6

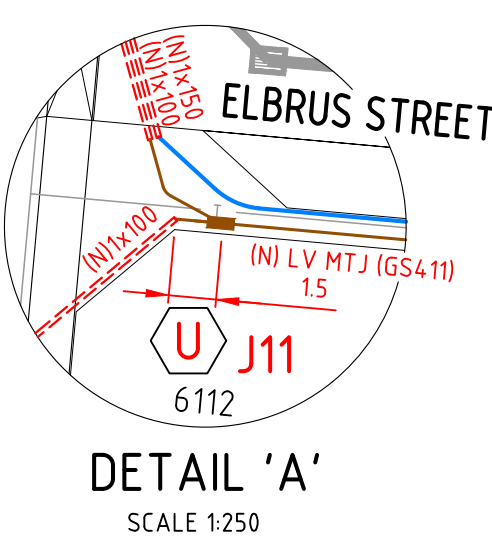
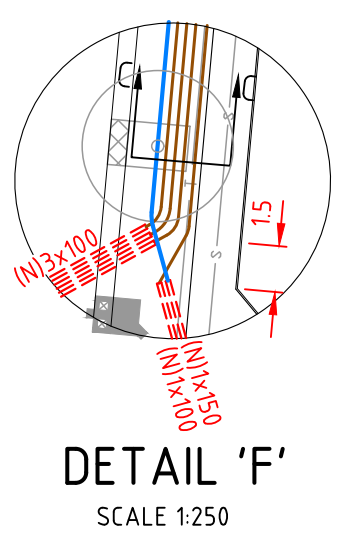
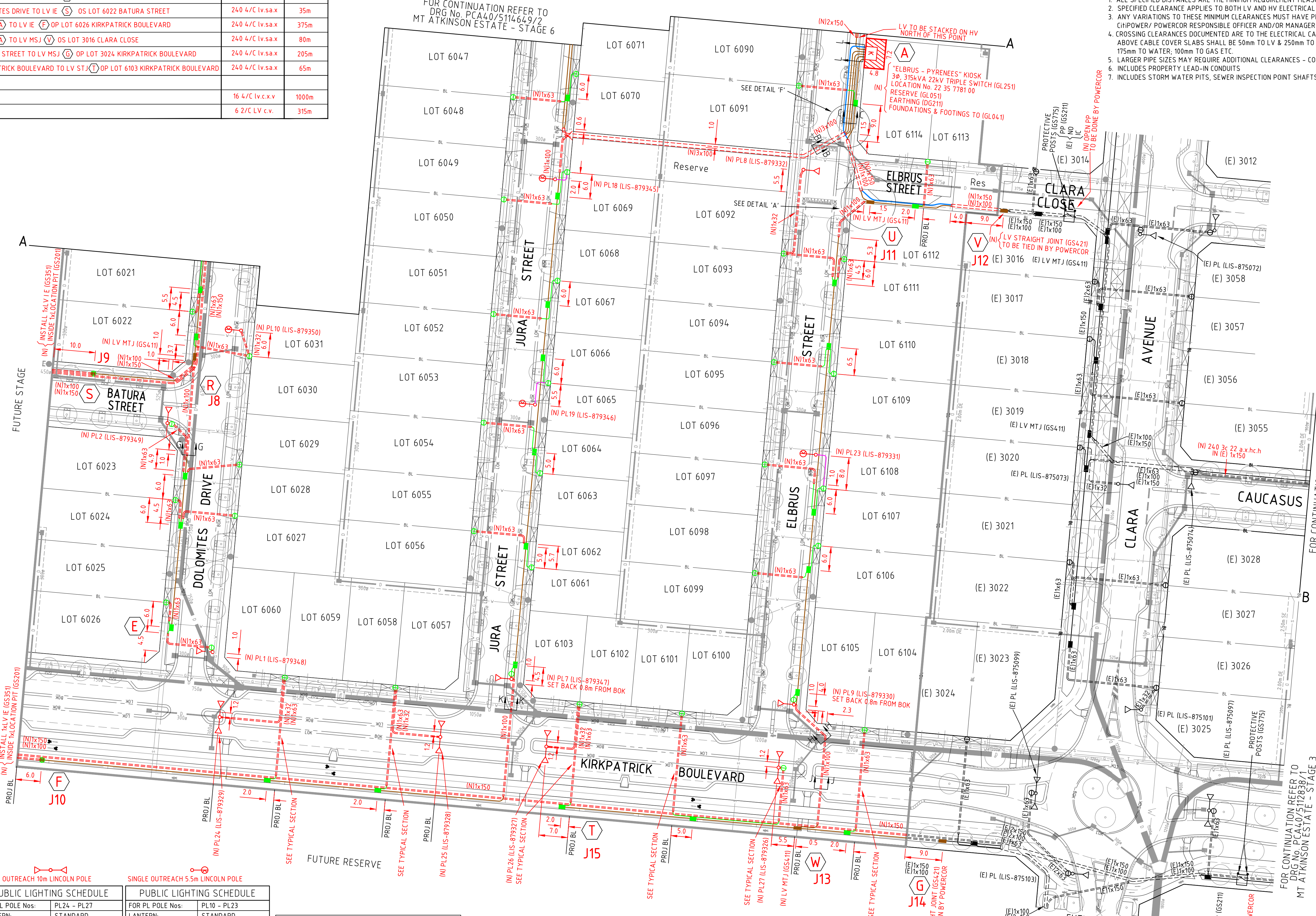

RECOVERABLE WORKS UPDATE LV & HV LABELS AT (E) 'CAUCASUS - ALASKA' KIOSK REFER TO PCA40/5112838/1

DEEP TRENCHING DUE TO SAFETY CONCERNS, TRENCHES FOR CONDUIT INSTALLATION SHOULD NOT BE DEEPER THAN 1.5m

REMOTE LV TIE-IN WORKS WORKS TO BE TIED IN BY POWERCOR (N) LV STRAIGHT JOINT (GS421) OP (E) LOT 3024 KIRKPATRICK BOULEVARD REFER TO PCA40/5112838/1

NO GO ZONE NO GO ZONES TO BE OBSERVED. NO OPTION 2 CONTRACTORS TO BREACH NO GO ZONES UNDER ANY CIRCUMSTANCES TO BE DONE BY POWERCOR TO PERFORM LIVE WORKS

DETAILING TRENCH SHOULD NOT BE SAND AND SLAB BEFORE ELECTRICAL ASSETS DETAILS HAVE BEEN COLLECTED

CONSTRUCTION CHANGES PROJECT MANAGER MUST BE NOTIFIED OF ANY CHANGE TO DESIGN DURING CONSTRUCTION CHANGES MUST BE DETAILED

REMOTE HV TIE-IN WORKS WORKS TO BE TIED IN BY POWERCOR (N) HV CABLE TERMINATION (GB251) INTO SWITCH NUMBER '57156' AT (E) 'CAUCASUS - ALASKA' KIOSK REFER TO PCA40/5112838/1

Public Lighting Schedule table with columns for Pole Nos., WATTAGE & TYPE MANUFACTURE, POLE, MANUFACTURER MODEL & CAT No, BRACKET, MANUFACTURER TYPE LENGTH COLOUR, COUNCIL.

PL NOTES ALL P/L POLES TO BE INSTALLED 10m FROM B.O.K UNLESS STATED OTHERWISE

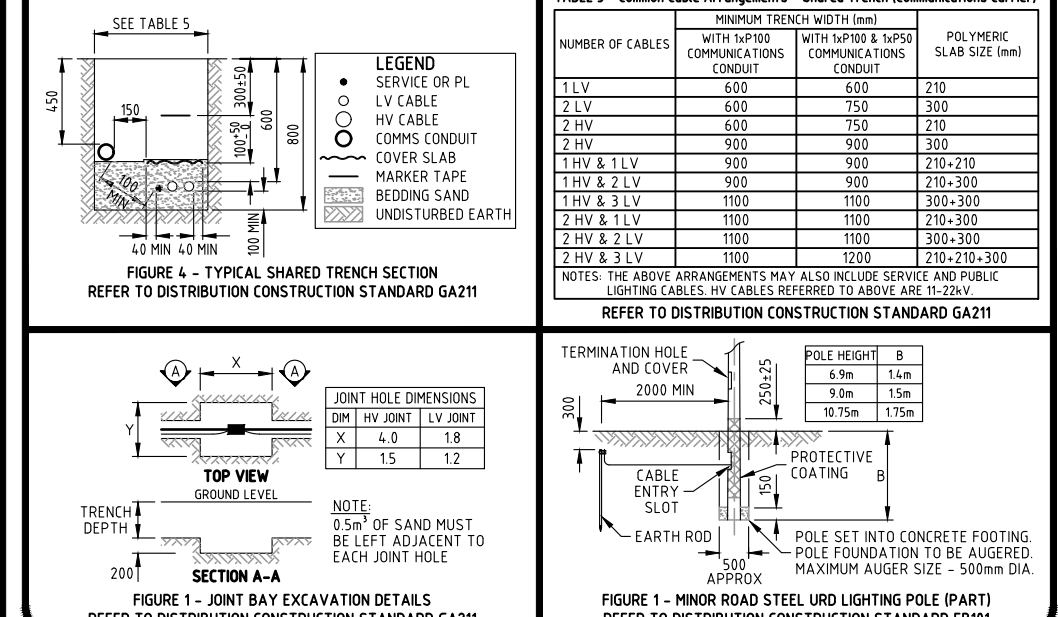
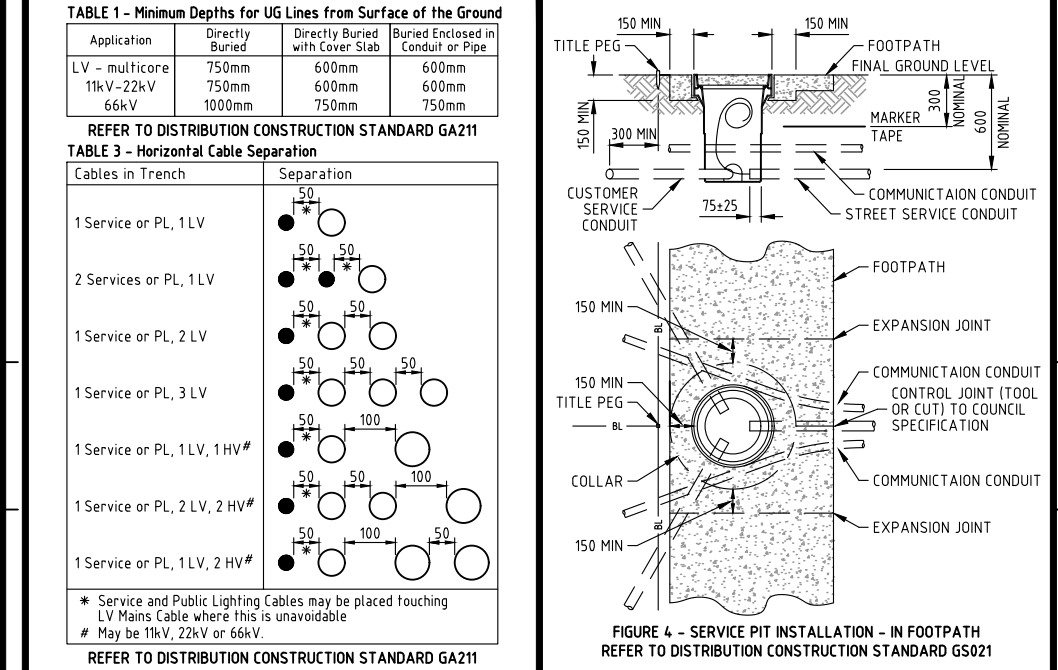
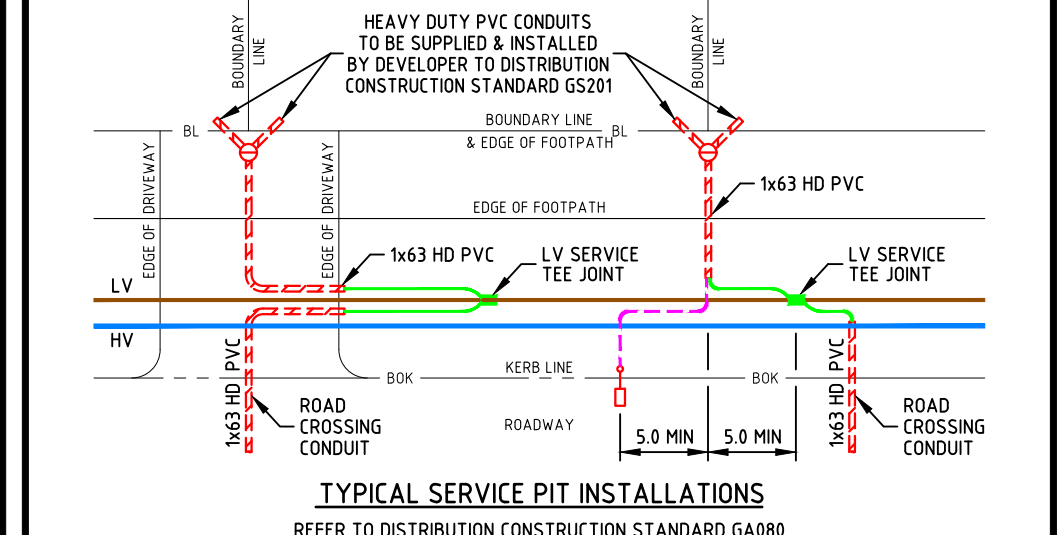
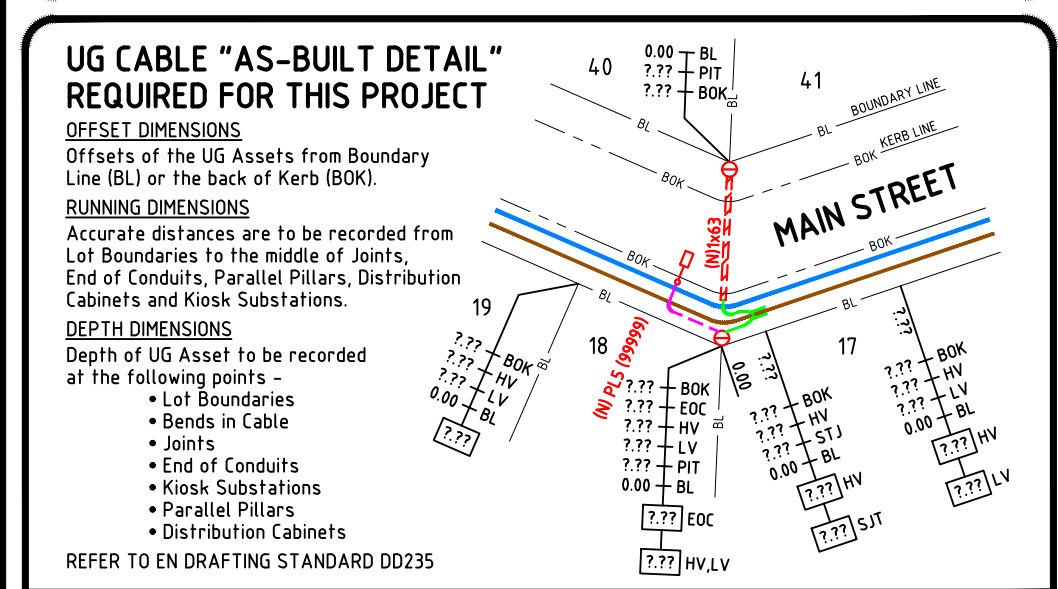

REFERENCE table listing Project Number, Road Directory, GIS System Plan, Projection, Feeder/Switching Zone, Developer/Number of Lots, Municipal Council, and other project details.

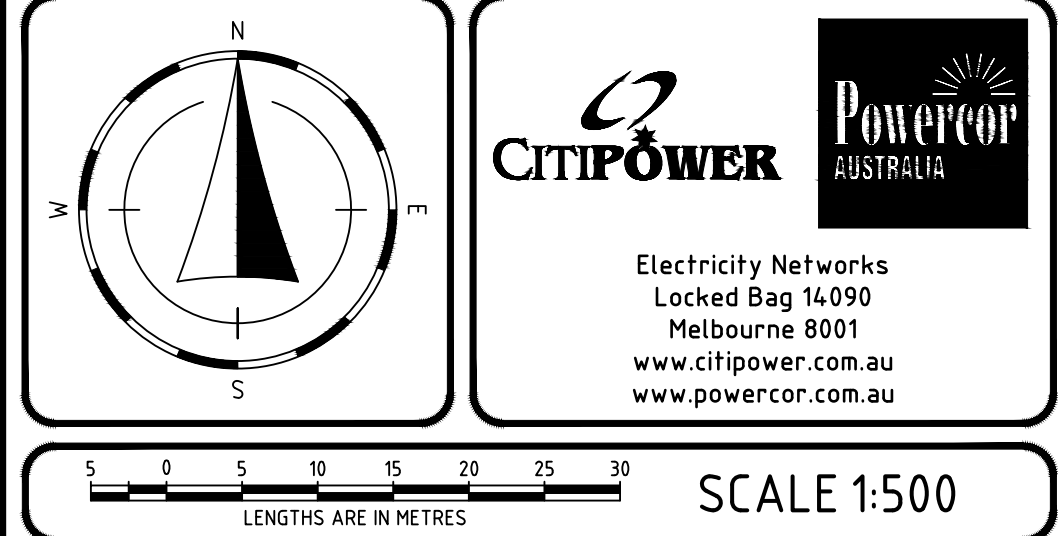

REVISION table with columns for Drawing Number, Revision, Date, and Description.

PROJECT INFORMATION table listing Drawing Title (KIRKPATRICK BLVD, DOLOMITES DR, JURA ST, TRUGANINA UG CONSTRUCTION PLAN - URD MT ATKINSON STAGE 6 DETAIL DESIGN), Drawing Number, Date, Designer, Design Approval, Project Manager, and other details.



Locality Map

Sequence No: 97171767

Greigs Road Truganina

MAP IS A GUIDE ONLY- REFER TO CABLE PLANS FOR ACCURATE ASSET LOCATIONS

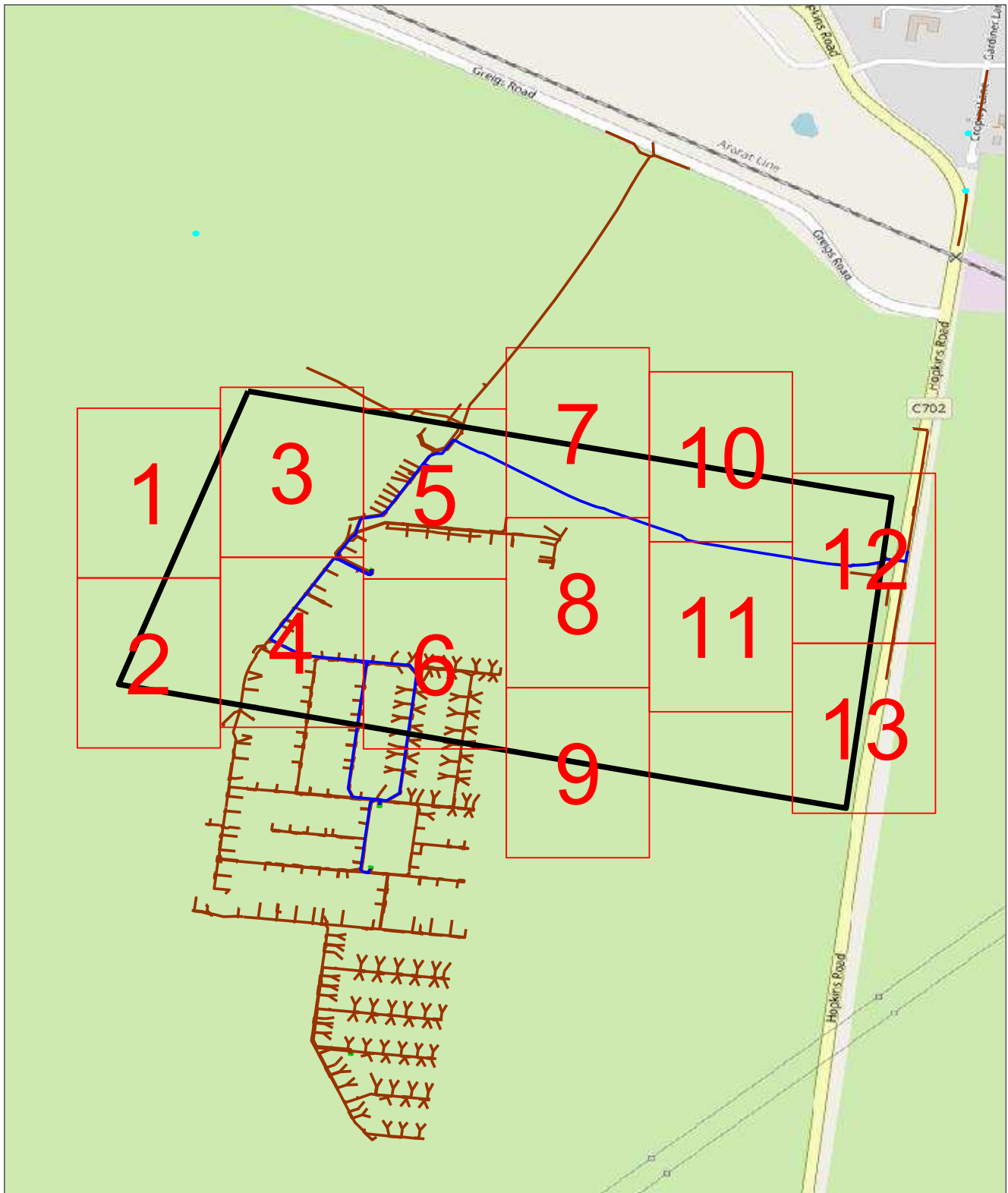

LEGEND:

- DBYD Work Area
- SWER Substation
- High Voltage Cable
- Communication Cable
- Zone Substation
- Distribution Substation
- Low Voltage Cable
- Earth Cable

This map represents the location of the submitted DBYD Work Area and all CitiPower/Powercor responses are based on this location. It is the responsibility of the enquirer to ensure the accuracy of the DBYD Work Area.

0 0.09km



Imagery sourced from Open StreetMaps

Appendix H – Existing Telecomm Assets

James Cappellari

From: Joseph Teoh <josephteoh@nbnco.com.au>
Sent: Tuesday, 29 June 2021 8:58 AM
To: Jessica Henry
Cc: Joe Cannatelli; Jim Bozikis - PBC
Subject: RE: Feasibility Request - Hopkins Road Business Precinct, Truganina

NBN Classification - Commercial

Hi Jess,

Apologies for the delay.

Luckily there appears to be a fibre joint out the front of the site so it's unlikely there would be additional backhaul costs (pending capacity). See below:

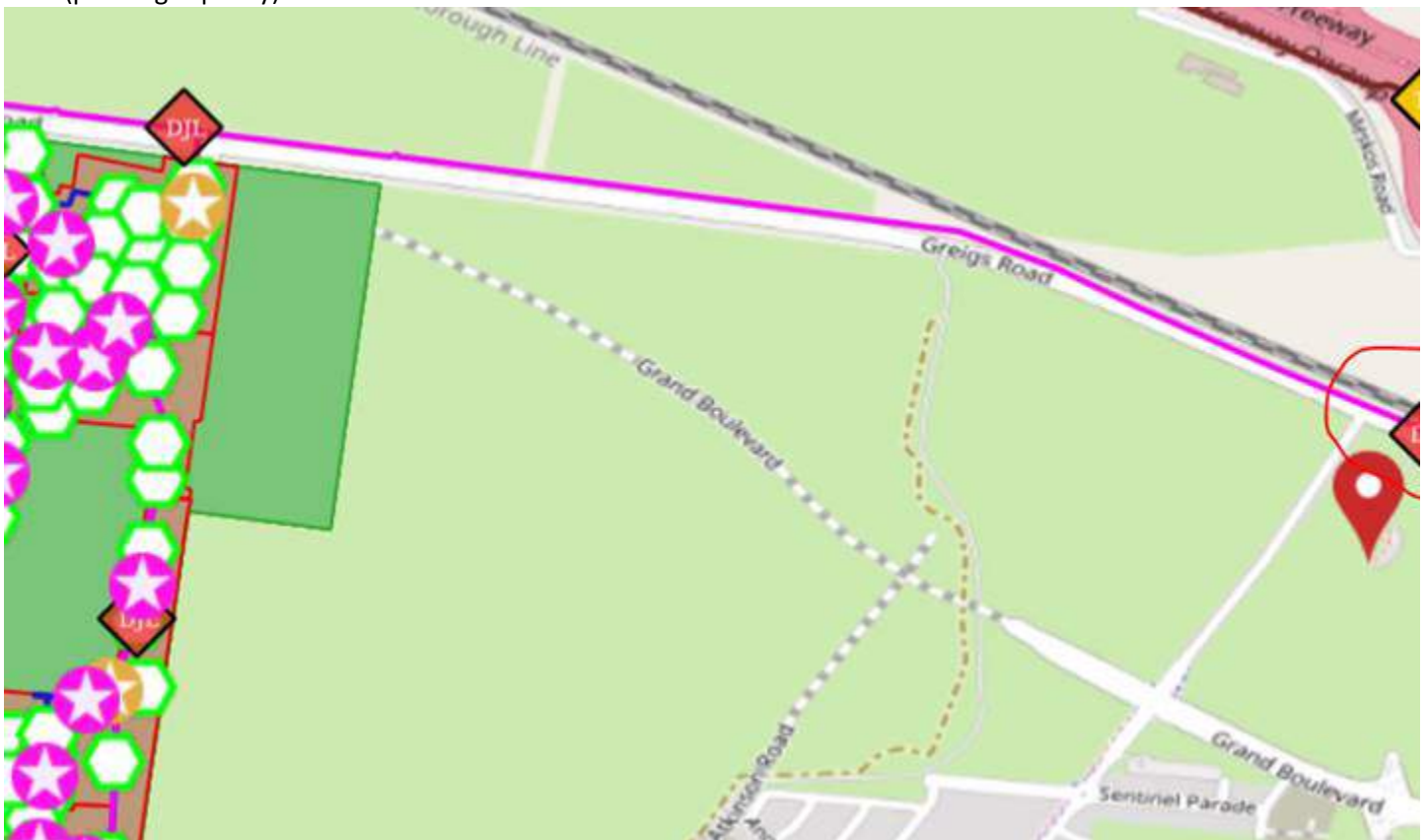

Due to the small lot count, we would still need to assess it manually.

I'd recommend registering it with the lot count of 35, providing us with the reference number, and we will make the adjustments to push it through the system.

Hope this helps.

Thank you

Kind Regards,

Joseph Teoh

Senior Account Manager (VIC/TAS) – New Developments

M +61 437 757 480 | E josephteoh@nbnco.com.au

Appendix I – Existing Gas Assets



NOTE: AusNet Services has taken care to ensure that the locations of Gas Mains shown on this plan are accurate however some variations from records do exist and complete accuracy is not guaranteed. It is essential that the position of pipes be proved on site by hand excavation. AusNet Services shall not be liable for any loss damage claim or demand incurred either directly or indirectly resulting from any act or omission which was made in reliance in whole or in part upon this plan.

Warning - Take Precautions if Printing this Plot in Black & White.
 All planned mains shall be treated as live mains, as mains under pressure may be in existence.

-  Gas Transmission Pipeline
-  Gas Distribution Mains
-  Planned Gas Assets
-  Abandoned Gas Assets
-  Requested Area

Appendix J – AusNet Transmission Guidelines

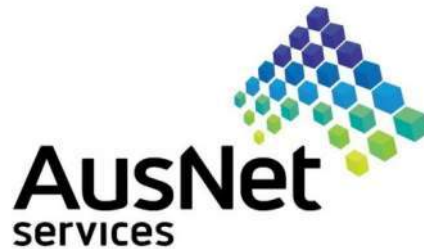

*AusNet Services
Asset Management*

GUIDELINES FOR SUBDIVISION AND DEVELOPMENT OF LAND AFFECTED BY TRANSMISSION LINE EASEMENTS

AusNet Transmission Group is the electricity transmission company operating under the AusNet Services brand name. AusNet Services also has an electricity distribution business (AusNet Electricity Services) and a gas distribution business (AusNet Gas Services).

Information for use by land owners, planners and developers in the planning and implementing of subdivisions, consistent with AusNet Transmission Group requirements for high voltage, overhead power line easements.

27/7/2015

p:\Guidelines Brochures Examples\guidelines subdivision & development AusNet Services.doc

GUIDELINES FOR SUBDIVISION AND DEVELOPMENT OF LAND AFFECTED BY EASEMENTS

CONTENTS

1. INTRODUCTION	3
1.1 Purpose of Guidelines.....	3
1.2 Preliminary Planning for Subdivision.....	3
1.3 Process for Approval of Subdivision Planning Applications.....	4
1.4 Process for Approval of Construction Works.....	5
1.5 Costs for Evaluations, Asset Relocations and Line Outages.....	6
2. PLANNING APPROVAL OF SUBDIVISIONS	7
2.1 Summary of AusNet Transmission Group Requirements.....	7
2.2 Easement Verification and Adjustment	8
2.3 Allotment Size.....	9
2.4 Allotment Boundary Locations	9
2.5 Roads in the Vicinity of Easements.....	10
2.6 Roads Crossing Easements.....	11
2.7 Provision of Services to Allotments.....	11
3. APPROVAL OF ENGINEERING DESIGN DRAWINGS.....	12
3.1 Buildings and Structures	12
3.2 Fences.....	12
3.3 Roadside and Allotment Services	13
3.4 Ground Surface Level Changes.....	13
3.5 Tree Plantings.....	14
3.6 Protection of Line Support Towers and Poles	15
3.7 Access for Line Maintenance and Construction	15
4. APPROVAL OF CONSTRUCTION WORKS.....	17
4.1 Conditions on Design Approval.....	17
4.2 Control of Construction Works	17
4.3 Construction Equipment Authorisation	18
4.4 Use of Explosives	18
4.5 Protection of Underground Cables.....	19
APPENDIX A - Permitted and Prohibited Uses of Power Line Easements	21
APPENDIX B - Layout of Subdivisions to Avoid Electric Hazards	23

GUIDELINES FOR SUBDIVISION AND DEVELOPMENT OF LAND AFFECTED BY EASEMENTS

1. INTRODUCTION

1.1 Purpose of Guidelines

AusNet Transmission Group Pty Ltd has a statewide network of overhead high voltage power lines, operating at voltages of 220,000 volts (220kV) up to 500,000 volts (500kV). These are generally steel lattice tower lines constructed within easements, which are recorded on the Certificate of Title of each affected property. The width of the easement is largely dependent on the number of existing and provision for future lines and their voltages. Some lines within AusNet Transmission Group's easements operate at lower voltages up to 66kV and are supported on smaller steel towers or wood or concrete poles. Whilst these lower voltage lines are located on AusNet Transmission Group's easements, they are operated and maintained by the local electricity distribution company.

AusNet Transmission Group does not own the land affected by the easement, but has the right to enter and use the easement for line construction, operation, patrol and maintenance purposes and to restrict activities carried out on the easement by others so that the initial high public safety, line reliability and bushfire prevention standards are maintained.

These guidelines provide information concerning AusNet Transmission Group requirements where subdivision and development of land subject to high voltage power line easements is proposed. It has been produced to assist with the planning and implementing of subdivisions, consistent with the AusNet Transmission Group's easement rights and the responsibility to protect people living, working and playing near the high voltage lines against electrical or other hazards that could cause serious injury or death.

Subdivision Planning Permit and Certification applications and Engineering design drawings that clearly comply with the requirements stated by these guidelines can be readily approved by AusNet Transmission Group. Proposals that do not clearly comply will require early consultation to determine whether approval can be given.

Landowners and developers are welcome to discuss the requirements with AusNet Transmission Group's Assets Department, on:

Telephone **1300 360 795**

Early and confidential consultation, prior to a Planning Permit application or drafting of detailed design drawings, would enable a subdivision layout to be optimised in the shortest practicable time.

1.2 Preliminary Planning for Subdivision

Preliminary planning for subdivision of property with an overhead power line easement should take into consideration the general information given in Appendix A concerning permitted and prohibited uses of high voltage line easements.

Planners should also be aware that the way in which land affected by high voltage power line easements is subdivided can have a significant effect on factors such as:

- Visual amenity of the area;

- Costs for fencing and servicing allotments (particularly electricity, street lighting, telephone, gas and water), consistent with prudent public safety requirements;
- Inconvenience and costs to AusNet Transmission Group and allotment owners caused by requirements for vehicle access for line construction, patrol and maintenance; and
- Public perception of possible adverse health effects from the electric and magnetic fields (EMFs) coming from the power lines.

Subdivision planners have an obligation to consider community values and attitudes to the visibility and safety of high voltage power lines when laying out allotments and roads. Since it is appropriate that the visibility aspects of planning be controlled by the developer and by the planning authority, it is not considered further by these guidelines.

The question of whether or not exposure to EMFs causes adverse health effects is unresolved. There is worldwide scientific consensus that such effects have not been established, but that more research should be undertaken. AusNet Transmission Group keeps the issue under close scrutiny, takes advice from health authorities and participates in EMF research.

1.3 Process for Approval of Subdivision Planning Applications

As a Referral Authority under the current legislation (Planning and Environment Act 1987), AusNet Transmission Group is consulted by the Responsible Authority (usually the appropriate Municipal Council) concerning its requirements for each subdivision planning permit application, whenever a high voltage power line easement is affected.

The steps involved in gaining approval of proposed subdivisions are:

- Issue of a Planning Permit by the Municipality. Permit conditions requested by AusNet Transmission Group and other Referral Authorities could normally be expected for any permit issued.
- Certification of the final, fully dimensioned Plan of Subdivision by the Municipality, following approval by the Referral Authorities.
- Issue of a Statement of Compliance by the Municipality, following advice from the Referral Authorities that the permit conditions have been satisfied, to enable registration of the Plan of Subdivision by the Land Titles Office.

For subdivisions affecting high voltage power line easements, the following AusNet Transmission Group requirements would normally be included as Planning Permit conditions:

- Written agreement to the final plan of subdivision must be obtained from AusNet Transmission Group prior to certification;

and; if roads or installation of services are proposed on the easement:

- Written approval of detailed construction plans (Engineering design drawings) for the proposed works must be obtained from AusNet Transmission Group prior to issue of the Statement of Compliance.

The AusNet Transmission Group response to a Planning Permit application may include comments concerning issues identified that must be considered in finalising the subdivision layout for Certification. Objection to an application would generally be made only if the amendments required would significantly affect the nature of the proposed subdivision.

AusNet Transmission Group consent to Certification of the final Plan of Subdivision is dependent on supply of full and satisfactory dimensional information showing the easement satisfactorily located in relation to the power line(s).

AusNet Transmission Group consent to issue of the Certificate of Compliance is dependent on prior approval of the Engineering design drawings, including satisfactory provision for the requirements outlined by these guidelines.

AusNet Transmission Group requirements for approval of Subdivision Planning Permit applications are stated in Section 2 of these guidelines.

1.4 Process for Approval of Construction Works

AusNet Transmission Group requires to approve all proposals for construction works affecting power line easements, including those for which Planning Permits are required, to ensure that public safety and AusNet Transmission Group's easement rights are preserved.

Approval is generally a two-stage process, as follows:

- (i) Engineering design drawings of proposed construction works, or any proposed alterations to previously approved designs, must be submitted to and be approved by AusNet Transmission Group prior to commencement of the works.

Applications for approval of design drawings are required to be submitted to:

**Survey and Easements Team
Asset Management Division
AusNet Services
Locked Bag 14051
MELBOURNE MAIL CENTRE VIC 8001**

<mailto:lmq@ausnetservices.com.au>

Information concerning AusNet Transmission Group requirements for approval of Engineering design drawings is given in Section 3 of these guidelines.

- (ii) The contractor performing the work on site must also contact AusNet Transmission Group at least five working days prior to any work commencing, so that the proposed construction works methods can be reviewed and any safety precautions deemed necessary can be taken.

However, the prior notice period becomes at least ten working days should there be a requirement for use of vehicles, machinery or other equipment exceeding 3 metres maximum operating height, or any equipment with an elevating component. The use of such equipment in the vicinity of power lines must be in accordance with the requirements of the Electricity Safety (Network Assets) Regulations 1999.

The factors considered by AusNet Transmission Group for approval of construction works are outlined in Section 4 of these guidelines.

1.5 Costs for Evaluations, Asset Relocations and Line Outages

There are no fees payable to AusNet Transmission Group for evaluation of Planning Applications or for supply of asset location information, such as record plans required for preparation of detailed construction design drawings.

However, AusNet Transmission Group will recover all of its costs in cases where AusNet Transmission Group assets require relocation, protection or modification in some way or where a significant design input is required for assessment of Engineering design drawings for a construction project. In such cases, AusNet Transmission Group will advise the party initiating the work of the intention to recover costs, the extent of costs involved and timing of the work, so that a funding agreement can be established prior to the commencement of the AusNet Transmission Group design work.

Costs for assessment of required equipment operating constraints and for any line outages required to carry out the work, including temporary earthing of the conductors, will also be recovered from the constructor.

2. PLANNING APPROVAL OF SUBDIVISIONS

2.1 Summary of AusNet Transmission Group Requirements

AusNet Transmission Group requirements for approval of subdivision planning applications that include land affected by high voltage power line easements are summarised as follows. Further information, including the basis of each requirement, is provided in the following Sub-sections 2.2 to 2.7:

- **Easement Verification and Adjustment**

Plans of subdivision submitted for certification and referred to AusNet Transmission Group will not be approved unless the easement as shown on the plan accords with the actual position of the power line(s) as verified by survey connections and computation.

- **Allotment Size**

AusNet Transmission Group advises that the unencumbered portion of lots affected by a high voltage power line easement should have a similar area to the area of nearby lots not affected by the easement.

- **Allotment Boundary Locations**

Plans of Subdivision submitted for Certification and referred to AusNet Transmission Group will not be approved if proposed lot boundaries are located within 4 metres of existing or planned future tower leg steel or poles.

However, the following larger separation distances and other dimensional requirements should be provided where practicable:

- For urban residential subdivisions with wood fences, lot boundaries should be located 15 metres from any face of a steel tower base where practicable. Not less than 4 metres clearance is permitted between any tower face and the boundary.
- Lot boundaries for industrial, rural and rural residential subdivisions that generally have metallic fences (including post and wire fences) should not exceed 100 metres in length on the easement or 250 metres in length on and within 20 metres of the easement. They should also be located at least 30 metres from the centre of existing and proposed towers, unless a reduced distance is advised by AusNet Transmission Group (Refer Appendix B).

- **Roads Crossing Easements**

Plans of Subdivision submitted for Certification and referred to AusNet Transmission Group will not be approved if proposed road reserve boundaries are located within 30 metres of the nearest tower centre, unless prior consultation satisfactory to AusNet Transmission Group has occurred.

Engineering design drawings for proposed works on the easement, including surface level changes, heights of lighting poles and locations of services need to be approved by AusNet Transmission Group before agreement can be given to the issue of the Statement of Compliance for the subdivision.

Height restrictions on the operation of vehicles and construction equipment must be carefully considered in planning the subdivision, since significant cost implications for installation of roadside services may be involved.

Roads Within and Alongside Easements

Planning permit applications and/or plans of subdivision referred to us that include proposed roads will not be approved by AusNet Transmission Group where the total length of the road reserve clearly exceeds the 100/250 metre length limits stated in Appendix B, unless prior agreement by AusNet Transmission Group has been obtained concerning the arrangements made for installation of services and road lighting and for protection of towers.

As for roads crossing easements, height restrictions on operation of vehicles and construction equipment on the easement must be carefully considered and AusNet Transmission Group approval of Engineering design drawings for works on the easement is required prior to issue of the Statement of Compliance.

- **Provision of Services to Allotments**

AusNet Transmission Group approval of Engineering design drawings for all works on the easement is required prior to issue of the Statement of Compliance.

2.2 Easement Verification and Adjustment

There is a need for accurate definition of power line easements, given the land use restrictions required for safe and reliable operation of the power lines.

The area shown on the Certificate of Title as "easement to the SECV (i.e. AusNet Transmission Group) for transmission of electricity" is intended to cover a specific corridor of land overlaying the route of the transmission line. This corridor is dimensioned by computation of electrical safety clearance distances appropriate to the design of the line and its operating parameters and is positioned by survey connection to title of the proposed power line centreline. Modern title re-establishment surveys sometimes reveal that the recorded easement location does not coincide precisely with the actual position of the existing power lines in the way originally intended.

There are a number of reasons why this may be the case. These relate to the nature of land title boundary definition, the age of the line and the nature of easement creation surveys:

- Differences over time in the position of adopted title boundaries due to the nature of title re-establishment. This is most likely to happen in areas that have not been re-surveyed since the early days of land subdivision;
- Early power line easements were surveyed using methods and equipment less sophisticated than they are now. As the land affected was predominantly rural, accepted tolerances were greater than what is now required for residential and commercial/industrial subdivisions; and
- Easement creation surveys are generally not as comprehensive as surveys for subdivision of land and so are subject to amendment when a difference is revealed.

It is important that the consulting surveyor contacts AusNet Transmission Group as early as possible in the development process so that any need for easement variation can be identified before detailed design of the subdivision is started. This is especially relevant when lot or reserve boundaries are proposed to be based on the easement boundary.

The location of the easement boundaries will be re-computed using the consulting surveyor's re-establishment of the title. Connections from the re-establishment survey to the power line centreline as defined by the towers or poles are necessary for this computation. This process should be discussed with AusNet Transmission Group. The new easement dimensions and

connections to title will be provided to the developer's surveyor for inclusion in the plan of subdivision.

An appropriate adjustment to the easement location is generally achieved on the plan of subdivision without the need for new easement creation or surrender procedures under the Transfer of Land Act. AusNet Transmission Group can provide details covering the notations required for the plan and on receipt of the plan showing the amended easement, will provide a letter authorising the variation addressed to the Registrar of Titles.

2.3 Allotment Size

Since buildings and structures, including swimming pools, are not permitted on high voltage power line easements, except for limited concessions regarding domestic outbuildings on 220 kV line easements, residential lots that are not large enough to accommodate a house, garage, swimming pool, etc. on land clear of the easement will be less useable than allotments of the same size that are not affected by the easement.

The expectations of a purchaser to be able to develop their land to a level comparable with that of neighboring allotments that are unaffected by the easement is considered by AusNet Transmission Group to be an important consideration in planning a subdivision.

Similarly, planning of industrial lots should take into account the requirements that generally prohibit the storage of materials and the parking, loading and unloading of large trucks on the easement.

Therefore, as a general principle, AusNet Transmission Group considers that the unencumbered portion of lots affected by a high voltage power line easement should be similar in area to the whole area of nearby lots planned for comparable use that are not affected by the easement.

However, since lot size is primarily a matter for control by the developer and by the Responsible Authority, AusNet Transmission Group does not normally object to a subdivision based on a comparative land use disadvantage for lots affected by easement.

2.4 Allotment Boundary Locations

Lot boundaries on transmission line easements should be located in consideration of prudent public safety measures, AusNet Transmission Group requirements for vehicle access to and between towers and the associated inconvenience caused to AusNet Transmission Group and to lot owners.

Installation of gates in fences on the easement is required where direct access to tower sites from public roads is not available. The number of gates, safety requirements (including special design of metallic fences) and the level of inconvenience is influenced by the number of lot boundaries intersecting the access route provided by the subdivision and on the separation distances provided between lot boundary fences and towers. Established AusNet Transmission Group access tracks should be preserved, unless a satisfactory alternative is agreed.

The minimum and preferred separation distances between allotment boundaries and towers stated in Section 2.1 are based on the following fencing issues:

- (i) Minimum of 4 metres between fences and the nearest face of the steel tower base - to provide for reasonable access around the tower base and permit use of standard electrical safety procedures by AusNet Transmission Group line maintenance personnel;

- (ii) Requirements for access gates to enter adjacent allotments for normal line maintenance activities are minimised where fences are located at least 15 metres from the nearest face of 500 kV and 330 kV towers, or 10 metres from 275 kV, 220 kV and 66 kV towers;
- (iii) The increased separation distances to towers and length limits for industrial, rural and rural residential subdivision lot boundaries stated in Appendix B, Tables 1 and 2, are based on avoiding the need for earthing and sectionalising of metallic fences, in accordance with Section 3.2 of these guidelines.

AusNet Transmission Group's requirements for working space around towers is explained further in Section 3.7 of these guidelines.

2.5 Roads in the Vicinity of Easements

Roads in the vicinity of transmission lines can potentially have an adverse effect on maintaining existing high standards of safety and security of the lines.

Roads within transmission line easements that run parallel or cut at an angle of less than 45 degrees to the power line/s are generally not permitted.

Proposed roads that are adjacent to an existing or future transmission line, but outside the easement, and are shorter than the maximum lengths as stated in Appendix B, Table 1, are generally acceptable, subject to AusNet Transmission Group approval of Engineering design drawings for works prior to issue of the Statement of Compliance for the subdivision.

Controls on road lengths in close proximity to high voltage power lines are required to limit the voltages that can be induced in roadside metallic objects and services to safe values.

The visibility of the line, exposure of towers to damage, hazards to AusNet Transmission Group maintenance personnel from road vehicles and the need to control service extensions for further subdivision development and later service upgradings or replacement works are additional factors requiring consideration.

Therefore, AusNet Transmission Group agreement to roads in the vicinity of high voltage transmission line easements is dependent on the total length of road proposed near the easement and satisfactory advice from the developer concerning the design provisions made that will limit induced voltages in metallic objects and services to safe values.

While it may prove possible, in some locations, to vary the maximum road and metallic service lengths stated in Appendix B, Table 1, this would be dependent on satisfactory results of detailed site investigations and calculations by AusNet Transmission Group based on the electrical design parameters of the affected line. Pre-payment by the developer of a fixed price for the study would normally be required and the response time would be dependent on other AusNet Transmission Group works commitments at the time.

- **Construction Equipment Height Restrictions**

The cost implications of height restrictions for vehicles and construction equipment required to be used on the easement are potentially more significant for roads along easements than for roads crossing easements and must also be carefully considered in planning the subdivision.

2.6 Roads Crossing Easements

- **Proximity to Towers and Poles**

Planned roads that directly cross an easement further from existing and future towers than the minimum separation distances stated in Appendix B, Table 1 (measured to the nearer road reserve boundary) are generally acceptable, subject to AusNet Transmission Group approval of Engineering design drawings for works on the easement prior to issue of the Statement of Compliance for the subdivision.

AusNet Transmission Group agreement to closer roads is dependent on satisfactory advice from the developer concerning the following:

- Surface level changes proposed on the easement;
- Provision for installation of roadside services;
- Provision for road lighting; and
- Road design near towers and measures planned to protect AusNet Transmission Group line maintenance personnel and prevent damage to towers.

Details of specific AusNet Transmission Group requirements for these factors are given in Section 3 of these guidelines.

- **Construction Equipment Height Restrictions**

Height restrictions on the use of vehicles, machinery and other equipment plant, must be carefully considered in planning the subdivision, since significant cost implications for installation of roadside services may be involved.

2.7 Provision of Services to Allotments

The restrictions on positioning of metallic pipes and cables near towers and maximum length requirements within and alongside high voltage power line easements stated in Sections 2.5 and 2.6 above also apply to the servicing of individual allotments, particularly rural and rural residential allotments where service line lengths are potentially large.

AusNet Transmission Group approval of Engineering design drawings for works on the easement prior to issue of the Statement of Compliance is also a requirement for subdivision applications for which the design of services to allotments is identified as a significant issue.

3. APPROVAL OF ENGINEERING DESIGN DRAWINGS

The requirement for AusNet Transmission Group to approve all proposals for construction works affecting high voltage power line easements results from the responsibility to maintain and protect the following:

- Safety of the general public, contractors and AusNet Transmission Group personnel;
- Security of AusNet Transmission Group assets and continuity of electricity supply;
- Vehicle access to AusNet Transmission Group assets at all times and in all weather conditions;
- Provision reserved within existing easements for planned future lines; and
- Potential for redevelopment of the easement for future power supply purposes.

Because of the variety of ways in which construction works can affect AusNet Transmission Group assets there is a need for close review by AusNet Transmission Group of both the design and construction method aspects of proposed developments.

The following additional information to that stated in Appendix A, concerns requirements selected as more relevant to subdivision proposals and is provided to assist with detailed planning and design.

3.1 Buildings and Structures

Buildings and structures, including swimming pools, are not permitted on high voltage power line easements, except for limited concessions regarding domestic outbuildings on 220 kV line easements, as outlined in Appendix A.

3.2 Fences

- **Earthing Requirements**

Long metallic fences close to high voltage power lines, for example farm type (post and wire) and chainwire mesh types, can have a voltage induced in the metallic (that is, electrically conductive) components. To limit the induced voltages to safe values, either the length must be restricted to the maximum values stated in Appendix B, Table 1, or the fence must be earthed to AusNet Transmission Group requirements.

Typical earthing requirements for post and wire fences would involve connection of the horizontal strain wires to earth spikes driven into the ground at intervals not exceeding 30 metres. For a fence using bare metal mesh or wire supported on bare metal posts, no additional earthing would generally be required.

- **Sectionalising Requirements**

An additional consideration relates to fences in the vicinity of steel towers and concrete poles. Under extraordinary operating conditions, typically during line faults, the ground voltage in the vicinity of the tower or pole can rise relative to the surrounding area.

To prevent any electrical hazard, the voltage occurring must not be transferred via fences (or other conductive objects) to areas remote from the tower or pole.

Accordingly, fences must be **either** kept clear of towers and poles by the minimum distances stated in Appendix B, Table 2, **or** sectionalised by insertion of an insulating section at each location where the fence enters the zone around each tower or pole extending to the appropriate Table 2 distance.

On request, AusNet Transmission Group can provide further advice and clarification of earthing and sectionalising requirements for particular fence designs and arrangements.

3.3 Roadside and Allotment Services

Similar requirements to those stated above for metallic fences apply to the total lengths and proximity to towers of buried metallic services, including water, drainage, sewerage and gas pipes, telephone cables and low voltage electricity supply cables, except that earthing and sectionalising may either not be practicable or involve a significant cost penalty.

In many situations, the most practical solution will be to locate the services well clear of the power line easement, as stated in Appendix B.

Roadway lighting poles proposed on the easement are also subject to height restrictions depending on the available clearances to the high voltage power line conductors and they must lower to the ground for servicing, including lamp replacement.

The length of non-metallic pipes (such as PVC and earthenware) is not restricted on the easement and reinforced concrete pipes are permitted provided that they are not located closer to towers and poles than the minimum distances stated in Appendix B, Table 2.

3.4 Ground Surface Level Changes

- **Clearances to Line Conductors**

No variation to existing ground surface levels under high voltage power lines is permitted without prior AusNet Transmission Group approval. Approval is subject to confirmation that the clearances to the line conductors will not be reduced below the required minimum design clearances under the conditions of maximum conductor sag (corresponding to the maximum line operating temperature) and the maximum design wind.

Because of the variety of line voltages, configurations, maximum operating temperatures and the effects of wind on the horizontal displacement of the conductors, AusNet Transmission Group must be contacted to provide advice on all aspects of conductor clearances.

A brick or timber sound wall or other roadside feature that can be climbed, providing a closer approach to the overhead lines, is generally not permitted in locations where only the minimum design clearance is provided.

- **Requirements Near Towers and Poles**

From consideration of AusNet Transmission Group requirements for the movement of personnel and vehicles and the handling of materials in the vicinity of towers and poles, the creation of uneven or poorly drained sites is unacceptable.

Lowering of surface levels in the vicinity of towers and poles is generally unacceptable to AusNet Transmission Group because of the detrimental effects on the stability of the structures.

A further consideration is that tower foundations, above ground members and pole stay wires have been installed with corrosion protection appropriate to the existing surface levels.

Where surface levels are proposed to be raised in the vicinity of towers or pole stay wires, the corrosion protection systems are required to be extended to cover the new height. The fill placement method and type of fill material must be controlled to ensure that no damage to members or protective coatings occurs and that no potential for long term damage is created from either fill settlement or chemical action.

For constructions that involve significant ground surface level changes over a wide area of easement, AusNet Transmission Group generally requires accurate survey measurements of the final surface levels to be undertaken by the Constructor for amendment of the power line design records. Alternatively, AusNet Transmission Group could undertake the survey work at cost to the Constructor.

3.5 Tree Plantings

Trees and shrubs with a mature growth height not exceeding 3 metres are permitted on high voltage power line easements. Taller species (generally limited to 6 metres maximum mature height) may be acceptable, subject to AusNet Transmission Group approval of the planting layout to verify that sufficient clearances to the conductors will be provided and that this can be readily assessed by AusNet Transmission Group line patrols. Other specific requirements are that the vegetation will not endanger the line in the event of vegetation fires and will permit satisfactory AusNet Transmission Group vehicle access to and around towers for line patrol and maintenance purposes.

Initial planting of approved species and locations, with regular vegetation maintenance, including removal of inappropriate regrowth, will eliminate the need for corrective action by AusNet Transmission Group and minimise the possibility of unavoidable damage during line maintenance works.

Vegetation density is generally restricted to scattered trees or limited area clumps and shelterbelts to control the total quantity of burnable materials on the easement.

Trees that grow to exceed the approved heights may be removed and costs charged to the property owner. Tall growing species will be removed at the earliest opportunity.

A tree clear area of 20 metres minimum radius is generally required at tower sites for line maintenance purposes. Closer trees may be permitted in some locations, where the interference caused to access and essential line maintenance is acceptable. A larger tree clear area is required at future tower sites to provide for construction of the new transmission line. Section 3.7 includes further comment on the requirement, to provide reasonable working space around towers.

To assist in the selection of appropriate tree/vegetation species, AusNet Transmission Group has an information booklet available on request.

3.6 Protection of Line Support Towers and Poles

- **Protective Barriers**

Constructions that include roads or involve the use of vehicles in the vicinity of high voltage power line towers or poles increase the risk of damage to the structures and hazards to AusNet Transmission Group employees. AusNet Transmission Group requires Constructors to address this risk by the provision of suitable barriers.

Installation of "New Jersey", "Armco" or an alternative design of barrier approved by AusNet Transmission Group as appropriate to the situation is required where a hazard may arise due to errant vehicles or loads. Particular hazards could result from road design factors, such as positioning the outside of a curve near a tower, or surface level differences that would not assist errant vehicles to return to the carriageway (for example, a roadway embankment higher than the natural surface level at the tower base).

The barrier must be located as close as practicable to the kerb, be designed to contain out-of-control vehicles and their loads within the carriageway and preferably not be within 15 metres of steelwork for 500/330 kV towers or 10 metres for 275/220/66 kV towers, to provide for normal line maintenance activities without the need for lane or road closure. The barrier design must also provide for site access by AusNet Transmission Group vehicles.

Metal and concrete barriers must also be at least 4 metres from the nearest tower leg steel/pole, to permit use of standard electrical safety procedures by AusNet Transmission Group maintenance personnel.

- **Structure Stability Requirements**

Construction works are not to affect the structural performance of AusNet Transmission Group assets. Where earthworks are proposed in the vicinity of poles or towers AusNet Transmission Group must be convinced that the performance of existing structure footings (particularly for uplift or overturning forces) is not compromised.

Also, the introduction of higher groundwater levels to footings not designed for the changed conditions would be unacceptable.

3.7 Access for Line Maintenance and Construction

Vehicle access by AusNet Transmission Group is required to existing and future tower and pole sites at all times for line patrol, maintenance and construction purposes. For many easements, gates 4.6 metres in width will be required in boundary fences to permit vehicle access along the easement. For property security purposes, provision is required for fitting of AusNet Transmission Group padlocks to gates.

In an emergency situation, work could be undertaken at night or day over extended periods and in extreme weather conditions.

Regular line patrol and maintenance activities can typically include monthly inspections using a 4.5 tonne vehicle, a 20 tonne bucket truck and support vehicle for insulator washing yearly and a 40 tonne crane once in ten years (heavy maintenance contingency).

- **Protection of AusNet Transmission Group Employees**

Since AusNet Transmission Group employees work on the easement on a regular basis, AusNet Transmission Group has an obligation to provide a safe work place within the definition of the Occupational Health and Safety Authority regulations. AusNet Transmission Group requires provision of safe access and safe worksites.

For constructions that include roads or involve the use of vehicles in the vicinity of high voltage power line towers or poles, approved barriers or other measures that satisfactorily reduce the risk of injury from errant vehicles or loads must be provided.

AusNet Transmission Group requires to approve the measures adopted but looks to the Constructor to present appropriate solutions having regard to the factors involved, such as the vehicle speeds, proximity of the road, differences in surface levels and the location of road curves relative to towers and poles.

- **Standard of Access**

The majority of high voltage power lines have been in use for many years. During this period, AusNet Transmission Group line patrol and maintenance personnel have established access tracks suitable for their purposes and an environment that is generally readily and inexpensively restored should surface or vegetation damage be unavoidable.

Associated with any proposed development, AusNet Transmission Group seeks to ensure that freedom of access at all times and under all weather conditions is not restricted, that the potential for damage (and therefore restoration costs) due to AusNet Transmission Group activities are not increased and that the pattern of existing patrol activities is disrupted to the least extent practicable.

Therefore, consideration needs to be given to the compatibility of proposed constructions (including multi-use pathways, tree planting, landscape mounding and fencing) with AusNet Transmission Group access requirements. For example, the provision of reinforced access through grassed areas and replacement access tracks having grades and turning radii suitable for movement of long chassis vehicles such as cranes and bucket trucks would be required for developments that significantly alter the access arrangements.

- **Access around Towers**

Towers require a reasonably large working space because of their size and consequently the type of equipment required to be used. The preferred minimum size clear worksite would be a level, compacted area free of obstructions within 20 metre of the tower steel in all directions including a surfaced hard standing rectangular area extending 20 metres from each side of the tower underneath the conductors and 5 metres from each side of the tower beside the conductors. The surfaced hardstand area provides a site for operation of winches, cranes or "bucket trucks" and parking of passenger vehicles and patrol trucks.

It is acknowledged that some towers may already have smaller available worksites than the preferred minimum size, due to existing landforms or obstructions and that the design of construction works may impose further restrictions. There is a requirement for discussion at the design development stage to ensure that the needs of both AusNet Transmission Group and the Constructor are accommodated.

4. APPROVAL OF CONSTRUCTION WORKS

4.1 Conditions on Design Approval

AusNet Transmission Group approval of Engineering design drawings for construction works affecting high voltage power line easements is normally subject to a number of conditions.

When no information is submitted by the Constructor concerning the equipment and construction methods proposed to be used, the following AusNet Transmission Group requirements are normally advised:

- A 3 metres maximum operating height limit for vehicles, machinery and other equipment used on the easement, with possible additional restrictions for items of plant equipped with an elevating component.
- The Constructor must contact AusNet Transmission Group at least five working days prior to any work commencing on the easement.

However, should a requirement be identified for use of vehicles, machinery and equipment that either exceed the 3 metres maximum height limit, or are defined as Cranes, the work commencement notice period is increased to at least ten working days to provide for detailed assessment of the safety clearances available to the high voltage conductors and the need for equipment operating limits and/or line outages. In practice, the longer the notice given by the Constructor, the less likelihood of delays to the site works.

Use of Cranes and vehicles, machinery and equipment higher than 3 metres may be acceptable at some work locations where greater than normal clearances to the line conductors are available. However, the required clearances must be determined by AusNet Transmission Group, since they are line voltage dependent and the line conductor positions can change significantly and without warning with variations in the electrical load, ambient temperature, wind strength and direction. It must also be appreciated that high voltage electricity can arc across distances of several metres, so that even a close approach can be dangerous.

4.2 Control of Construction Works

AusNet Transmission Group is required to check that the works are in accordance with the approved drawings, review the works procedures and construction equipment proposed to be used against the available clearances and required minimum safety clearances to the high voltage conductors and towers and arrange for any safety precautions deemed necessary to be taken.

An "Application for a Permit to Work Adjacent to AusNet Transmission Group's Exposed High/Low Voltage Electrical Apparatus" may be required to be signed by the Constructor prior to commencement of the work. AusNet Transmission Group's local Lines Team Leader would then arrange for written authorisation entitled "Permit to Work Adjacent to AusNet Transmission Group's Exposed High/Low Voltage Electrical Apparatus" for the time to be nominated and no work would be permitted without this permit.

Line outages, where required, are subject to operational availability. AusNet Transmission Group does not accept liability for any delays or costs to the constructor for the safety precautions and line outages required.

Any construction works in the vicinity of AusNet Transmission Group transmission lines are required to comply with the following statutory regulations designed to protect people and property and prevent interference to AusNet Transmission Group lines and other assets:

- Electricity Safety (Network Assets) Regulations 1999.
- Occupational Health and Safety (Plant) Regulations.

The Victorian “Code of Practice for Plant No. 19, 1 July 1995” provides guidance to plant users on how to meet the requirements of the OH&S (Plant) Regulations, including identification and control of workplace hazards. For safe operation of Cranes, Australian Standard AS2550.1-1993 Cranes - Safe Use is specified as the appropriate technical standard to be followed.

4.3 Construction Equipment Authorisation

No work is permitted on the easement involving any change in surface levels, use of any vehicle, machinery or equipment exceeding 3 metres in maximum operating height, or defined as a Crane by the OH&S (Plant) Regulations 1995, regardless of the operating height, without the prior approval of AusNet Transmission Group.

Proposals submitted for construction approval should include reference to the design approval by AusNet Transmission Group, and a description of the task including the maximum equipment and load reach in both the vertical and horizontal planes, the operating location with respect to the lines and proposed controls on the operation of each item of equipment to maintain statutory clearances.

Full and detailed proposals should be submitted at least ten working days prior to the programmed commencement date. The proposed date and time should be confirmed five working days prior to commencement. A charge may be made for evaluation of proposals.

Australian Standard AS2550.1-1993 Cranes - Safe Use, Clause 7.17, specifies the precautions required to be observed when operating a crane in close proximity to overhead power lines. For transmission lines on towers, a minimum safety clearance of 6 metres is required to be maintained, unless designated otherwise by AusNet Transmission Group, based on the line voltage. An additional distance must generally be added to allow for possible line conductor movements resulting from changes in the electrical current flow and the weather conditions (ambient temperature, wind strength and direction).

AusNet Transmission Group will assess submitted equipment operation proposals with consideration to the clearances available and contingent controls and precautions that may be required. Line outages, where required, will be subject to operational availability. Costs for outages will be advised at this time.

Since transmission system security requirements, in conjunction with programmed maintenance works, frequently result in restrictions on the availability and duration of high voltage line outages, any significant cost implications for construction works on easements should be carefully assessed by the Constructor.

Commencement of design approved works that can be achieved within the 3 metres maximum operating height limit must be advised to AusNet Transmission Group with at least five working days notice.

4.4 Use of Explosives

- **No electrical detonation**

Electrical detonation of explosives must not be used on the easement as there is a danger that pre-detonation could occur due to the operation of adjacent overhead or underground lines. There is also the added danger that detonation wire may fly and contact overhead conductors.

Electrical detonation of explosives away from the easement may also be affected by power line fields and accordingly the advice of suppliers of explosives must be sought and acted on before electrical detonation is used in the vicinity of high voltage power lines.

- **Proximity limits**

Explosives could affect AusNet Transmission Group assets in either of three ways:

- Structural damage due to ground movement;
- Damage due to fly rock; or
- Maloperation of sensitive equipment due to ground acceleration.

Because of the range of circumstances in which explosives could be used, AusNet Transmission Group does not set specific guidelines except that no explosive shall be used within 10 metres of a tower, pole or underground cable without specific AusNet Transmission Group approval.

The charge size, placement and detonation rates must be determined with regard to the proximity of AusNet Transmission Group assets. When given sufficient notice, AusNet Transmission Group will provide advice on the age and likely condition of assets, so that the Constructor can ensure that proposed blasting is carried out without risk of damage.

However, where damage occurs to AusNet Transmission Group assets, the Constructor responsible for the blasting will be held liable for the cost of restoration.

Where large scale use of explosives is planned, AusNet Transmission Group requires to be given 6 weeks notice to assess the likelihood of any effect on any sensitive equipment at terminal or substations in the vicinity.

If explosives are used, movement of blast mats must be controlled and care must be taken to prevent damage to AusNet Transmission Group assets caused by fly rock.

4.5 Protection of Underground Cables

- **Identification of Cable Locations**

In locations where AusNet Transmission Group may have underground cables in the vicinity of proposed works, attention is drawn to the following:

- Location information for AusNet Transmission Group cables can be obtained by contacting **Dial Before You Dig**, telephone 1100 (24 hours). At least 48 hours notice prior to commencement of site works is required to provide for identification and on-site marking of affected cable locations;
- Cables are buried at depth to provide protection and safety. No change in depth of cover is permitted without AusNet Transmission Group approval. An increase in the depth of cover may adversely affect the performance of the cable and also the ability of AusNet Transmission Group to access and repair it.

The location of any AusNet Transmission Group underground cables must be determined before proceeding with excavation works, boring or driving of stakes, piles or the like.

- **Work Requirements Near Cables**

Mechanical excavation, boring or pile driving is not permitted within 1.5 metres of the indicated position of cables.

Where excavations are required closer than 1.5 metres to a cable, to a greater depth than the cable (such that support of the cable may be compromised) or where the location of the cable may be in doubt, subject to implementation of any special precautions deemed necessary by AusNet Transmission Group, the location of the cable may be proven using hand tools only.

With the cable alignment thus proven, mechanical plant may be used within 0.5 metres.

For the purposes of pavement construction over cables, with prior AusNet Transmission Group approval, tracked heavy crawler type equipment may be used with 450 mm of cover over cables.

- **Working Space Required for Cables**

An accessible area of at least 1.5 metres width either side of the cable is required to enable it to be repaired as necessary. In cases where cables are installed through ducts under road surfaces a spare duct should be provided. The spare duct covers the situation where the cable fails within the first duct and the duct is damaged beyond reuse.

APPENDIX A - Permitted and Prohibited Uses of Power Line Easements

The following restrictions and conditions concerning activities in the vicinity of high voltage power lines are required to ensure that public safety is not compromised by incursions within AusNet Transmission Group's easements and that the reliability of the lines is maintained. Prior approval is also required for any proposed alterations to approved developments on the easement to ensure that the initial high safety standards are maintained.

AusNet Transmission Group does not accept liability for any damage to the development caused by the operation and maintenance of the line.

Permitted Uses of Power Line Easements Include:

- Grazing and agriculture.
- Market gardens, orchards and horticultural nurseries, excluding buildings.
- Water storage dams, subject to sufficient clearances from the conductors and towers, including effects on water tables at tower sites.
- Trees and shrubs with a mature growth height not exceeding 3 metres. Taller species (generally limited to 6 metres maximum mature height) may be acceptable, subject to AusNet Transmission Group approval of the planting layout to verify that sufficient clearances to the conductors will be provided. Vegetation density restrictions and tree clear area requirements near towers to permit line maintenance works also apply.
- Landscaping and paving, subject to sufficient clearances to the conductors and towers if alterations to the natural surface levels are proposed.
- Fences up to 3 metres in height, suitably earthed and sectionalised if metallic/incorporating metallic materials.
- Sewerage, drainage and water pipes constructed of earthenware or plastic materials.
- Parking of sedan and utility types of vehicles. Barriers of an approved design may be required to protect towers from damage by vehicles.
- Tennis courts on 500 kV and 330 kV easements, provided that the net and umpire's chair are off the easement and the surrounding fence is a minimum of 30 metres from any tower steelwork.
- Tennis courts on 220 kV line easements, provided that metal net posts are used. An umpire's chair is also permitted, provided that it is of all metal construction, with a metal screen above the seating position. The minimum distance from the surrounding fence to the nearest tower steelwork reduces to 20 metres for 220 kV line easements.
- Ground level sporting activities, such as football, cricket, golf, basketball and netball, subject to special requirements regarding the design of metallic fences, goals and lighting.
- Lighting poles, subject to sufficient clearance from the conductors and towers. The power supply must be underground and the lighting poles must lower to the ground for servicing, including lamp replacement.
- Walking and bicycle paths, subject to suitable provision for access by AusNet Transmission Group vehicles.

- Playground equipment, subject to a 1 metre maximum height limit.
- For 220kV line easements only - car, boat and small trailer sales yards, excluding buildings.
- For 220kV line easements only, domestic garages, carports and garden sheds may be permitted a limited distance onto the easement, subject to a number of requirements including sufficient safety clearance to towers and overhead conductors, 3 metres maximum height, constructed largely of non-flammable materials and not attached to a dwelling.

Prohibited Uses of Power Line Easements Include:

- Houses, other buildings and structures, including eaves, awnings, canopies, shelters, water tanks, boreholes and windmills.
- Scaffolding.
- Swimming pools, both above ground and below ground types, including filtration equipment.
- Storage of flammable fuels.
- Storage of materials, including waste bins and stockpiling of excavated materials.
- Fueling of and repairs to vehicles.
- Use of vehicles and equipment exceeding 3 metres in operating height. A higher operating height limit is subject to sufficient clearances to the conductors. Possible additional restrictions apply to items of plant defined as a Crane by the Occupational Health and Safety (Plant) Regulations 1995.
- Parking of caravans and trucks.
- Loading, unloading and load adjustment of large trucks.
- Operation of large water spray irrigators of the gun type.
- Metal pipes (including reinforced concrete), electric power cables and other electrically conductive services within 30 metres of any tower steelwork, or exceeding 100 metres in length on the easement or 250 metres in length on and within 20 metres of the easement. For 220 kV easements, this minimum distance from towers reduces to 20 metres.
- Electrical detonation of explosives.
- Excavations to a depth exceeding 0.9 metres within 15 metres of any tower or 0.3 metres within 1.5 metres, without prior written approval.
- Flying of kites and model aircraft controlled by wires within 45 metres of any line.

APPENDIX B - Layout of Subdivisions to Avoid Electric Hazards

Metal objects located close to high voltage power lines are subject to induced voltages caused by electrostatic, electromagnetic and conductive couplings. If required, AusNet Transmission Group can provide further information concerning the fundamental mechanisms of electric induction.

Subdivision developments typically include installation of the following types of metal objects and allotment services, for which special design measures could be required (depending on their size/length and proximity to the power lines) to limit the induced voltages and any resulting electrical currents to safe values:

- chainwire mesh, or post and wire fences;
- low voltage power cables, including street lighting;
- telephone cables; and
- high pressure gas and water pipelines;

Generally, the best and least cost method of avoiding possible hazards caused by proximity to high voltage power lines is to stay far enough away, so that there is no significant interaction between the metal objects and the power line.

Therefore, the following tables provide guidance concerning the maximum lengths of metal fences and services and the minimum separation distances from towers to avoid any requirement for special design measures:

**Table 1 - Maximum Parallel Lengths of Metal Fences and Services
(Applicable to 66 kV - 500 kV Power Lines)**

Location of Metal Object	Maximum Length (metres)
On the easement	100
Within 20 metres of the easement	250

**Table 2 - Minimum Separation Distance
(Measured to the Tower or Pole Centre)**

Line Voltage (kV)	Minimum distance (metres)
500, 330 tower	30
275 tower	25
220 tower	20
66 tower	16
66 pole	3

A guide to living with transmission line easements



Introducing AusNet Services

AusNet Services owns and operates the electricity transmission system in Victoria.

Our network of transmission towers and terminal stations support some 6,500 kilometres of conductors (the wires) and it links with neighbouring states, including Tasmania, as part of the national electricity grid. The corridors of land on which this network is built are referred to as transmission line easements.

AusNet Services is committed to working with Victorian landowners to ensure that our easements are maintained and used in a manner that will provide for the safe and reliable flow of electricity through the network. We have written this booklet to provide landowners and managers with helpful information about your rights and responsibilities in relation to the use of these easements.

We appreciate you taking the time to read through this material, and are more than happy to provide you with any additional information you require or to assist with your planning. Another booklet in this series, *Your Guide to Planting Near Electricity Lines*, may also be a helpful source of information.

AusNet Services' electricity and gas regions

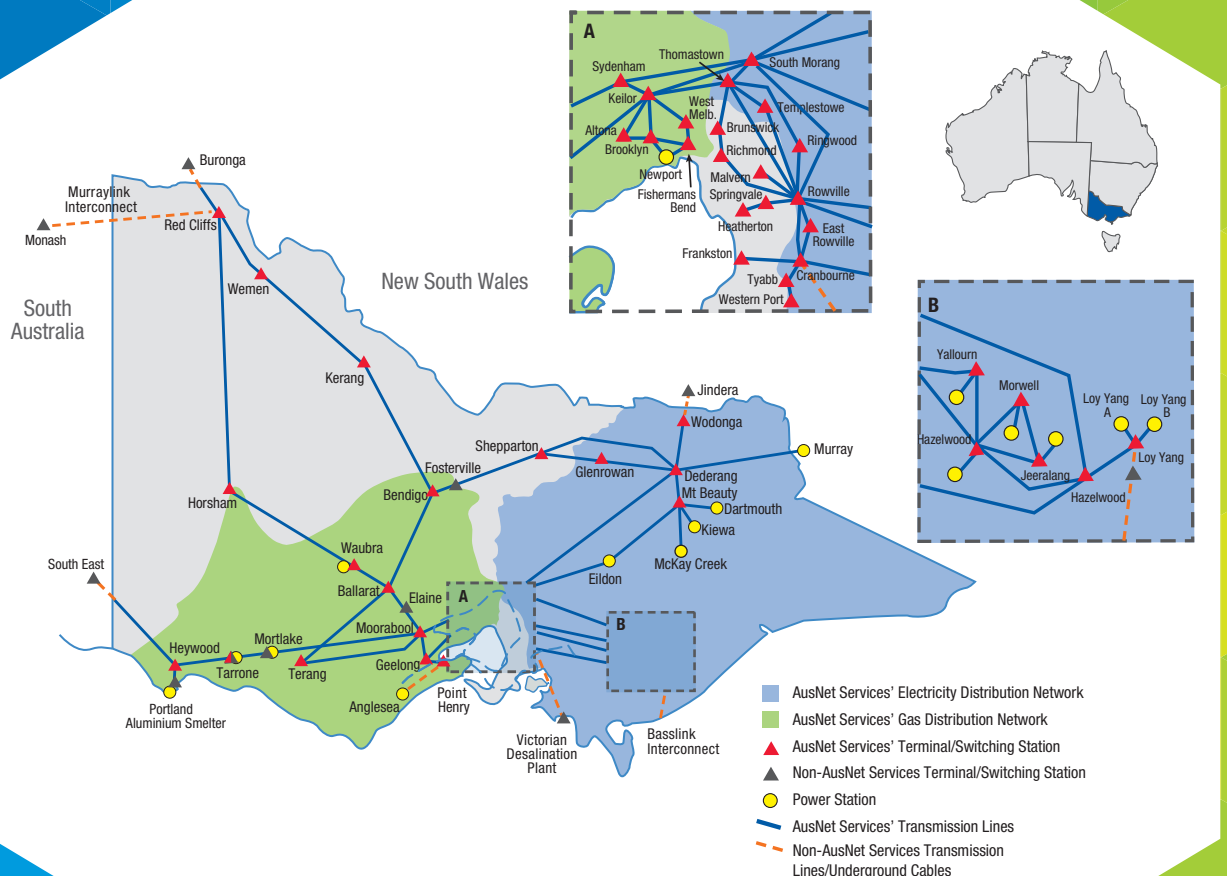

Easements within the transmission network

Most of us take our electricity for granted. Every time we switch on a light, iron a shirt or watch TV, we just expect the power to be there so our appliances will work. We don't even think about where the electricity comes from or how it gets to us.

A vast network of transmission lines has been built to ensure electricity reaches you, your neighbours, and millions of Victorian homes and businesses. These lines – owned by AusNet Services – carry electricity through their conductors (the wires) at extra high voltages of 220,000 volts (220 kV) to 500,000 volts (500 kV) from the power stations to the major load centres where the voltage is stepped-down (transformed) and the local distribution companies supply it to homes and businesses.

The vast majority of AusNet Services' conductors are supported on steel towers. The grounds on which the towers stand and conductors cross are known as transmission line easements. There are 6,500 kilometres of transmission lines crossing a total area of some 17,500 hectares of easements across Victoria.

For the purposes of this document, 'easement' refers to the land surrounding transmission lines, including government and privately-owned land.

It is AusNet Services' job to maintain the transmission system, and the easements provide ready access to the lines for maintenance, repairs and construction work to be carried out safely, 24 hours a day. The easements are also important for community safety.

We communicate with bodies such as Energy Safe Victoria to reasonably limit the activities, vegetation and buildings permitted on easements. Our priority is to eliminate potential electrical or fire hazards – both for the safety of the public and landowners, and the electricity system in general. Another major priority is to protect and nurture native ecosystems, flora and fauna that also inhabit the easements.

This guide provides you with some important information about the electricity transmission system and the easements on which it is situated. It also contains some vital information about what activities you can and can't carry out on easements.

Underground transmission cables

While the majority of AusNet Services' transmission lines are constructed on steel towers, there are also a significant number of 220kV transmission cables installed underground that are managed by AusNet Services.

In this regard, prior to commencement of any works involving digging, excavation, change of ground surface cover or driving of stakes or posts into the ground, a Dial Before You Dig enquiry must be made.



Making an enquiry about an easement

If you wish to enquire about a transmission easement on your property, or on a property you may be considering buying, complete the application form at the rear of this publication and forward it to:

AusNet Services
Asset Management
Survey and Easements
Locked Bag 14051
Melbourne City Mail Centre VIC 8001

The application form is also available on AusNet Services' website (www.ausnetservices.com.au) and can be lodged electronically Img@ausnetservices.com.au

Easement policy

In fulfilling our role, AusNet Services takes into account our legislative responsibilities and the interests of the community through:

- > creating awareness of the AusNet Services Easement Policy through promotion to landowners, land managers and the community in general;
- > recognising and observing planning and environmental constraints;
- > consulting with local authorities and interest groups, such as Landcare Australia, the Department of Environment, Land, Water and Planning and local Councils and groups with regard to AusNet Services' vegetation management activities and methods;
- > providing advance notice of our activities wherever practical and consulting with land users, local authorities and others having an interest in AusNet Services' activity;
- > fostering long-term compatibility of the immediate environment with transmission lines to minimise fire, safety and security risks and to minimise disturbance to landowners and occupiers by limiting the frequency of visits required to sites;
- > retaining the services of an arborist to provide expert advice where specific vegetation issues such as tree habit and regrowth rates arise;
- > encouraging property owners, land managers and community groups to plant compatible local native species in the vicinity of powerlines;
- > replacing incompatible tall-growth species of vegetation with lower-growing local native varieties;
- > removing tall trees adjacent to the easement that have the potential to cause line damage or fire risk; and
- > taking action against infringements to line clearance and inappropriate developments on easements to restore safe and compatible conditions.

Easement widths

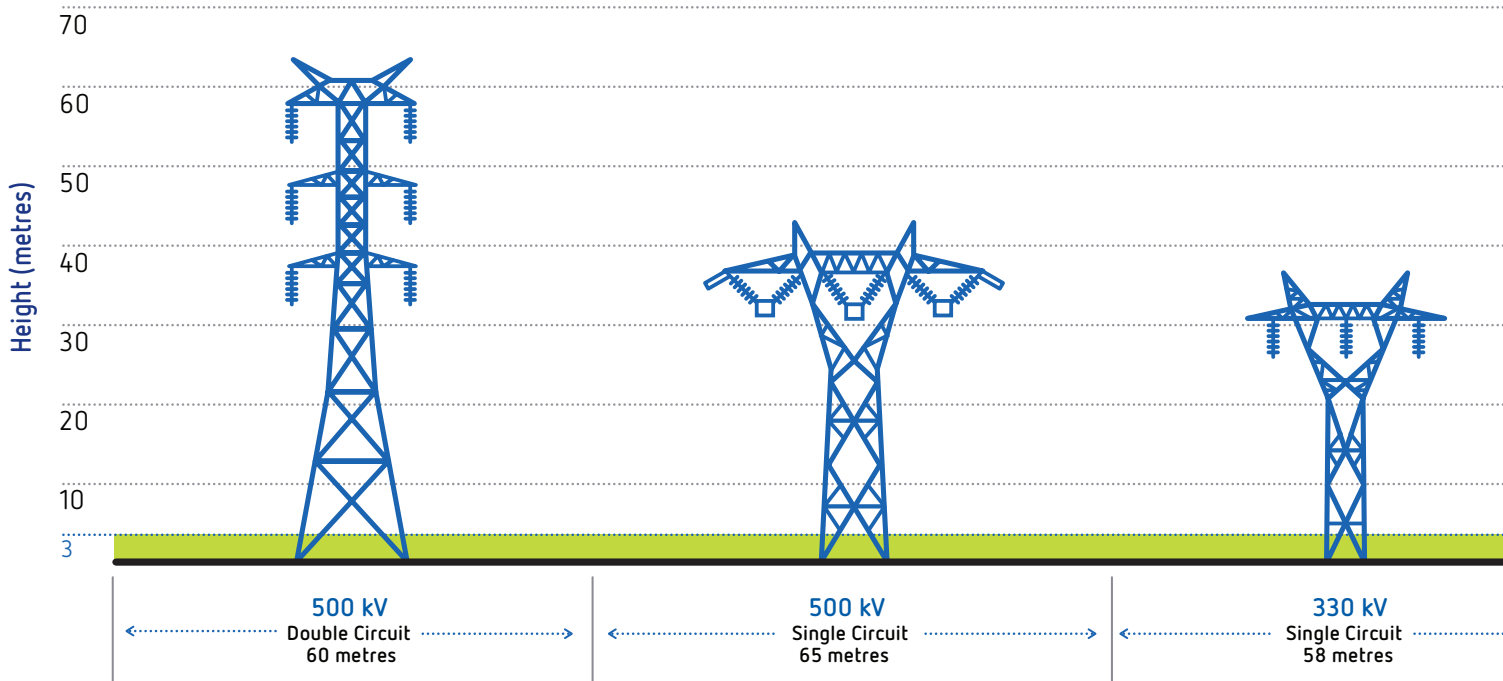

Main system components

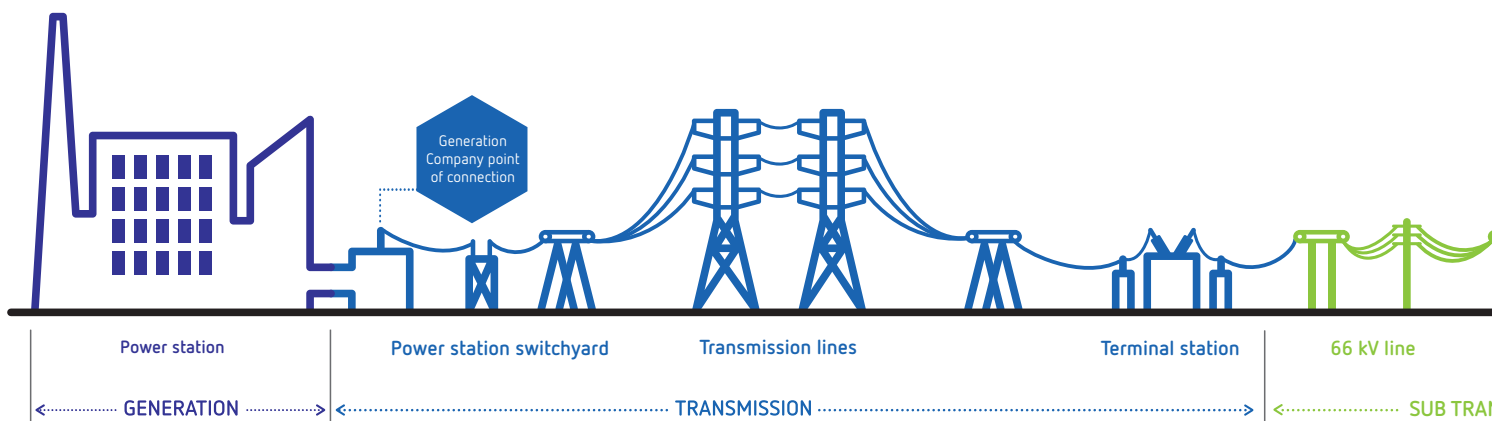

What are electricity transmission line easements?

AusNet Services' easements secure a corridor of land or 'right of way' for existing or future lines, and allow us access for maintenance and repair purposes as well as for safety control measures.

Other authorities have easements as well. They include drainage and sewerage easements, pipeline easements, and easements for overhead and underground powerlines for your local electricity distributor.

Transmission line 'conductors' are the actual wires that are suspended from the towers along which electricity travels.

These conductors may move many metres both horizontally and vertically under the effects of wind, temperature and electrical load. This movement is the basis on which easement widths and use conditions are determined.

Who owns the land the easement is on?

Usually AusNet Services does not own the land contained within the easement, but has acquired rights for its use by agreement with, and compensation of, the original landowner. Ownership of that land remains with the landowner, who has restricted use of the easement; however, to ensure the safety of landowners and the community, AusNet Services has statutory authority to restrict the activities that can be carried out on easements.

Note that the actual easement details may vary from typical widths, but are recorded on the Certificate of Title, which should be your first point of reference.

3m is the maximum mature height of vegetation on easements

kV = kilovolts or thousand volts

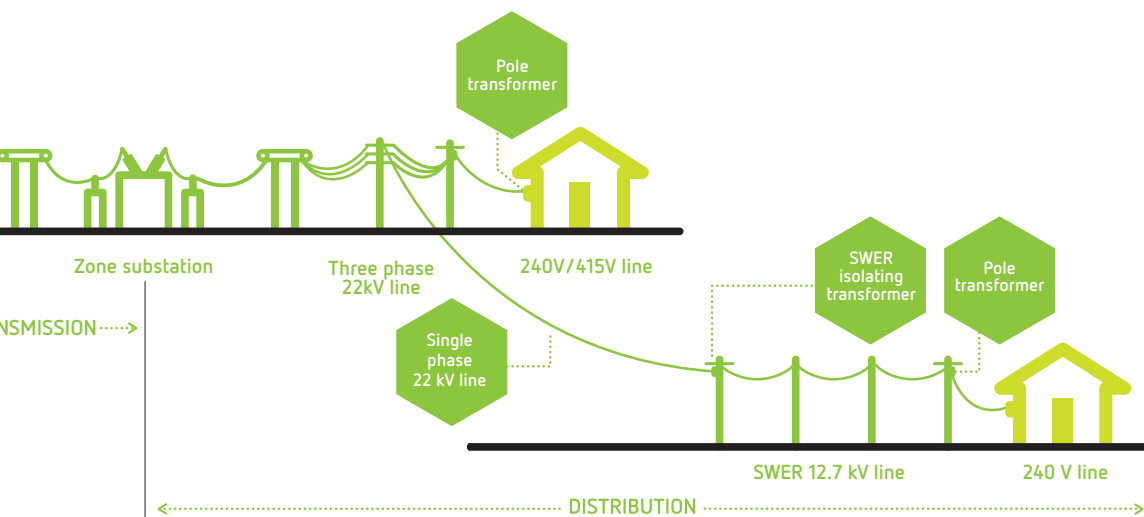
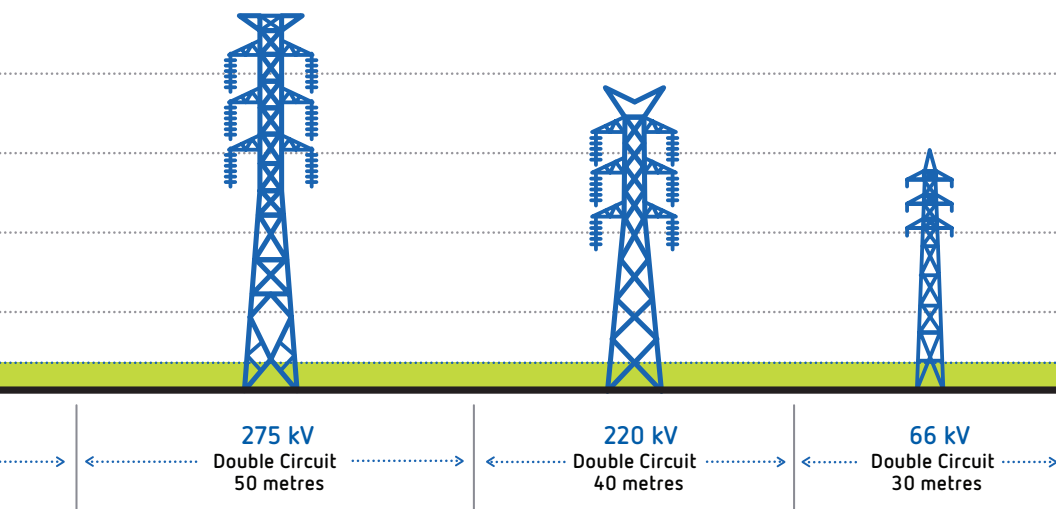

Who is responsible for the easement?

In general, maintenance of the area covered by the easement is the responsibility of the landowner or tenant (depending on terms of use). Easements must be maintained subject to the safety restrictions mentioned in this booklet.

AusNet Services reserves the right to carry out additional land management functions within the easement where unsuitable vegetation, ground surface level conditions, or other activities compromise the safe and reliable operation of the transmission lines.

On some properties, access roads and tracks were constructed specifically to build and maintain the transmission lines. AusNet Services retains the right to use these tracks for building and maintenance. We therefore maintain the tracks to four-wheel-drive standard in order to preserve vital access to the transmission lines.

If, for your own purposes, you require the tracks to be maintained to a higher standard, these costs are your responsibility.

How do you know if there are easements on your property?

Please check your Certificate of Title. If you want to obtain a copy, contact the Land Registry Office at:

Land Victoria
Land Registry
570 Bourke Street
Melbourne VIC 3000

Telephone (03) 8636 2010

A Title search can also be conducted via the Land Victoria website:
www.land.vic.gov.au

For prospective property buyers, please check the Vendor's Statement attached to the Contract of Sale to see if there are easements on the title.

Restrictions on easement use

AusNet Services' primary concern is for everyone's safety, and you can help; all it really takes is common sense. If you want to carry out any development, whether or not it requires council approval, please check with AusNet Services to see if the easement will be a constraint. You will need written approval from AusNet Services before commencing work on an easement, as a local council building permit is not sufficient authority. Failure to obtain AusNet Services approval may result in having to remove or modify the new work at your expense. So please check with us first, and avoid disappointment and needless expense.

In general, restrictions limit the use of easements to mainly ground level activities. Our concern for your safety is paramount. Together we must work to prevent hazards from powerlines that may result from reduced clearances, fire, impact or an explosion from any activity on the easement.

Always check with us first

Just to be on the safe side, you must always submit your plans for proposed development on an easement to AusNet Services before you start work on the site. This includes plans for installation of additional lighting, underground services, and to operate construction equipment, or to detonate explosives in the vicinity of an easement (contact details are on page 3).

Help us help you

To help us respond to your questions or proposals, the following details must be supplied:

- > the completed application form included as an appendix to this publication;
- > clearly dimensioned plans, preferably to scale, showing your proposal in relation to the property boundaries and, if possible, to the AusNet Services easement boundary. The plans should clearly indicate the dimensions (length, width and height) of any proposed structures;
- > location plans of the property, showing main roads and the position of any towers on the property; and
- > a copy of the Certificate of Title.

AusNet Services receives many applications for proposed works on easements, so the processing of your application may take some time. Generally we are able to respond to your application within 30 days. Please ensure that you send your request well in advance of the start of your planned works (the address is on the back of this booklet).

What if you have already built something on the easement without AusNet Services' authorisation?

If you have built something on an easement and you are not sure if it conforms to our guidelines, please give us a call and we would be happy to look into your enquiry.



What other kinds of activities can be carried out on easements?

AusNet Services requires the following restrictions and conditions be adhered to, thereby ensuring that public safety is not compromised by inappropriate activities within easements and to ensure that the reliability of the line is maintained. Prior AusNet Services approval is also required for any proposed alterations to approved developments on the easement to maintain the initial high safety standards.

Please take some time to read over the following guidelines carefully.

Permitted uses of transmission line easements

- > Grazing and agriculture.
- > Market gardens, orchards and horticultural nurseries, excluding buildings.
- > Water storage dams, subject to sufficient clearances from conductors and towers. Please consider the effects on water tables.
- > Trees and shrubs with a mature growth height not exceeding three metres.
- > Vegetation density is generally restricted to scattered trees or limited area clumps and shelter belts to control the total quantity of burnable materials on the easement.
- > A tree clear area of 20 metres radius is generally required at tower sites for line maintenance purposes. Closer trees may be permitted in some locations where the interference caused to access and essential line maintenance is acceptable. However, a greater clearance area is required at future tower sites to provide for construction of new transmission lines.
- > Landscaping and paving, subject to sufficient clearances to the conductors and towers if changes to the natural surface levels are proposed.
- > Non-metallic fences up to three metres in height. Metallic fences, or fences incorporating metallic materials, must be suitably earthed and sectionalised and are subject to AusNet Services' approval.
- > Sewerage, drainage and water pipes constructed of earthenware or plastic materials, but no closer than 20 metres to towers.
- > Parking of sedan and utility types of vehicles. Barriers of an approved design may be required to protect towers from damage by vehicles.
- > Tennis courts on 500 kV and 330 kV easements subject to certain specific requirements. Please contact AusNet Services for fencing requirements and further information.
- > Tennis courts on 220 kV line easements, provided that earthed metal net posts are used. An elevated earthed umpire's chair is also permitted, provided that it is earthed, of all-metal construction, with a metal screen above the seating position. Perimeter fences should also be earthed. Please contact AusNet Services for earthing requirements and further information.
- > Ground level sporting activities, such as football, cricket, golf, basketball and netball, subject to special requirements regarding the design of fences, goals and lights.
- > Lighting poles, subject to sufficient clearance to the conductors and towers. The power supply must be underground and the lighting poles must lower to the ground for servicing.
- > Playground equipment, subject to a 1 metre maximum height limit.
- > For 220 kV line easements only – car, boat and trailer sales yards, excluding buildings.

Prohibited uses of transmission line easements

- > Houses, other buildings and structures, including eaves, awnings, canopies, shelters and the like. For 220 kV line easements only, domestic garages (non-habitable), carports and garden sheds **MAY** be permitted a limited distance onto the easement subject to a number of requirements being met. These include sufficient safety clearance to towers and overhead conductors; three metre maximum height; construction made largely of non-flammable materials and not attached to a dwelling.
- > Erection of scaffolding.
- > Swimming pools, both above and below the ground, including filtration equipment.
- > Storage of materials in industrial type waste bins and skips.
- > Stockpiling of excavated materials.
- > Storage or handling of flammable liquids or gases. For 500 kV easements only, the storage or handling of such liquids or gases from bulk delivery vehicles is not permitted within 60 metres of the centreline of the transmission line.
- > Fuelling of and repairs to vehicles, plant and equipment.
- > Use of vehicles and equipment such as cranes, excavators, elevated working platforms and the like exceeding three metres in operating height. A higher operating height limit is subject to sufficient clearances to the conductors and requires the issue of a 'Permit to Work Adjacent to Exposed High Voltage Electrical Apparatus'. To arrange a Permit contact AusNet Services by email on img@ausnetservices.com.au.
- > Parking of large trucks and caravans (traversing or crossing easements is permitted).
- > Loading, unloading and load adjustment of large trucks.
- > Operation of large water spray irrigators of the gun type.
- > Metal pipes (including reinforced concrete), power cables and other electrically conductive materials within 30 metres of any tower steelwork.
- > For 220 kV easements only, this minimum distance reduces to 20 metres.
- > Electrical detonation or storage of explosives including fireworks.



Application for approval of (or general enquiry regarding) structures, buildings, or other use or activity on an electricity transmission easement

Property details

Street No. Street

Suburb/Locality

Applicant details

Name

Address (if different to above)

Street No. Street

Suburb/Locality

Telephone

Email

What do you want to do on the easement?

(Provide a detailed description of the building, use or activity that you wish to carry out on or near the easement).

.....

.....

.....

.....

.....

.....

.....

IMPORTANT: A plan (or plans) MUST be submitted with this application detailing the location on site of the proposed use or activity. The plan(s) must include distance from the property boundaries to the proposed use, and if possible should indicate the easement boundary. The dimensions of the proposed use, including length, width and height of any structures must also be shown. Provision of a copy of your title plan will assist us to process your application promptly.

Send completed application and plan(s) to:

AusNet Services
Asset Management
Survey and Easements
Locked Bag 14051
Melbourne City Mail Centre VIC 8001

Or email to img@ausnetservices.com.au





Other important considerations

Explosives

You must not use explosives on AusNet Services' easements. If you need to detonate explosives in the vicinity of the easement you must exercise care and not use an electrical detonation device. Please inform AusNet Services before you carry out any explosions in the vicinity of an easement.

Damage

AusNet Services shall not be responsible for any damage to any development you are carrying out on the easement caused by the operation and maintenance of the lines.

Electric and Magnetic Fields (EMF)

These fields are present whenever electricity is transmitted, distributed and used, and are therefore found in most places in modern society. Their effects can sometimes become evident through interference to electrical appliances or metallic objects. The health effects of EMF have also been the subject of public debate.

Health authorities appropriately determine the assessment of possible health effects and the Victorian Human Services Department and the National Health and Medical Research Council guide AusNet Services in these matters. Assessment of research results by the health authorities establishes interim guidelines on limits of public and occupational exposure to EMF and AusNet Services presently operates the transmission network within these guidelines.

Discharges, micro-shocks or a tingling sensation under or near transmission lines

Sometimes an electric field can be present under a high voltage transmission line. When you touch nearby metal objects such as long wire fences or metallic roofing or work with large metal objects, you may feel an acute shock or the hairs on your skin vibrate. Proper earthing methods or working procedures will eliminate these discharges.

Please contact AusNet Services for further information on discharges from wire fences, clotheslines or large metallic objects. EMF may cause some interference to electrical equipment and appliances in your home or workplace.

The type of interference you might experience includes television and radio interference and computer monitor or video display unit (VDU) interference.

Television and radio interference

Clear television and radio reception depends on many factors, including the receiving equipment, antenna, broadcast signal quality and atmospheric conditions.

Therefore, for good television and radio reception, you should install the receiver and antenna properly in an area with an adequate broadcasting signal.

However, the reception quality may also depend on whether there are interfering signals from other local sources such as electrical appliances, communication equipment or nearby faulty powerline hardware. You can report the interference to, and receive help from:

The Australian Communications and Media Authority (ACMA)

PO Box 13112

Law Courts Melbourne VIC 8010

Telephone: (03) 9963 6800 or 1300 850 115

Facsimile: (03) 9963 6899

Computer monitor or VDU interference

The screen display on common computer monitors or VDUs is driven by the unit's internal magnetic circuitry. Under certain conditions, external magnetic fields from a nearby source may interfere with the monitor and affect the quality of the display with a jitter or a slight screen distortion. Magnetic field sources in commercial and industrial buildings (and occasionally homes) often come from equipment such as internal substations, main electrical switchboards, heavy-current cables, and external power distribution and transmission lines. If this happens, check that the computer equipment and local magnetic field sources are properly installed. If you think that the magnetic field sources come from outside electrical installations, you can obtain further assistance from your local electricity distribution company. Refer to your electricity account for contact details. Please contact AusNet Services if you suspect the interference relates to high voltage transmission lines.

Vehicle access

AusNet Services and our contractors need vehicle access to existing and future tower sites at all times for line maintenance and construction purposes. In many cases, gates 4.6 metres in width are required in boundary fences to permit access along the easement. AusNet Services personnel and contractors entering properties will leave gates in the same open or closed position that they were found in.

Contact us

Customer enquiries

1300 360 795 8am–5pm Monday to Friday

Electricity transmission towers faults and emergencies

1800 111 164 24 hours a day, 7 days a week

Email: csc@ausnetservices.com.au

www.ausnetservices.com.au

Connect with us

 @AusNetServices

 AusNet Services

 13 14 50

