

PLAN
NOT TO SCALE

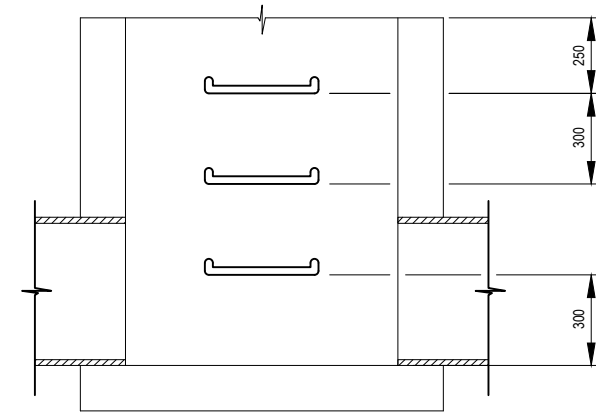

SECTION A - A
NOT TO SCALE

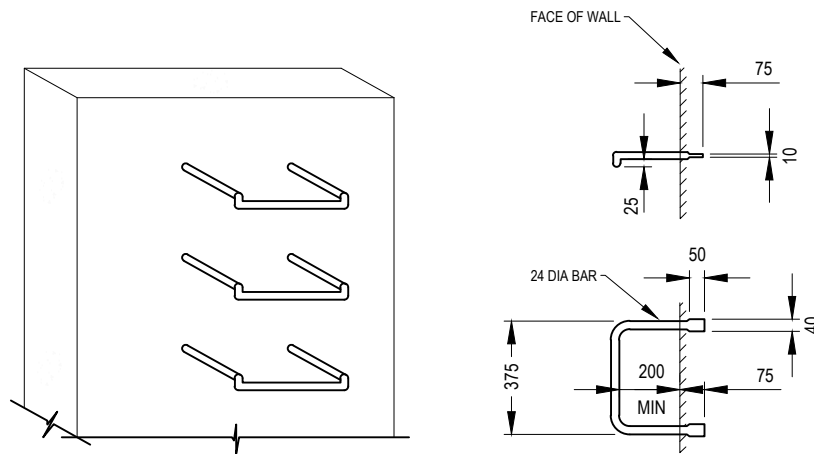

STEP IRON DETAILS
NOT TO SCALE

NOTES:

1. PITS DEEPER THAN 1000 TO BE FITTED WITH STEP IRONS.
2. STEP IRONS SHALL BE LOCATED DIRECTLY BELOW THE OPENING IN THE COVER AND DESIRABLY ON A WALL WITHOUT PIPE OPENINGS.
3. WHERE STEP IRON LADDER CHANGES FROM ONE WALL TO THE ADJACENT WALL, STEP IRON LADDERS TO OVERLAP BY 1200mm MINIMUM.
4. STEEL FOR STEP-IRONS SHALL BE STRUCTURAL GRADE 250 TO AS3679 PART 1.
5. STEP IRONS SHALL HAVE SHARP EDGES ROUNDED AND HOT DIP GALVANISED AFTER FABRICATION TO AS/NZS 4680.
6. PROPRIETARY POLYPROPYLENE STEP IRONS (OR APPROVED ALTERNATIVE) MAY BE USED. THESE SHALL BE INSTALLED ACCORDING TO THE MANUFACTURERS INSTRUCTIONS.
7. FOR PRECAST PITS, STEP IRONS SHALL BE LOAD TESTED TO AS4198/1994.
8. FOR REINFORCEMENT DETAILS REFER TO EDCM 605-608.

0	FINAL ISSUE	DG	MM	-	16.11.15
No	Revision	Note: * indicates signatures on original issue of drawing or last revision of drawing	Drawn	Checked	Approved
					Date



STANDARD DRAWINGS FOR
SUBDIVISIONS IN GROWTH AREAS
STEP IRONS

Revision | 0
Date | DEC 2015
EDCM 609