



# **Tract Consultants Pty Ltd**

## Rockbank Town Centre Utility Servicing Review

January 2018

# Executive summary

GHD has been engaged by Tract Consulting to conduct a peer review of the *Rockbank Precinct Structure Plan 1099 Services Report* prepared by Spiire dated 12 November 2013 (Appendix A) for the Rockbank Town Centre.

In preparing this report, GHD re-opened the lines of communication with utility providers to confirm if the recommendations and advice documented in the Spiire Report are still valid and what changes have occurred since 2013. This report outlines the key issues, constraints and opportunities within the existing utility infrastructure networks and provides an updated understanding as to the ability of this infrastructure to accommodate increased loads caused by development of the Rockbank Town Centre.

Key findings of the investigation were:

- A new sewer pump station with capacity to cater for up to 5,000 lots within the Rockbank Town Centre has been constructed recently and is located north east of the Troups Road North Railway Crossing. This station will be augmented to increase its overall capacity when required
- Additional sewer infrastructure has been installed to connect the new Troups Road sewer pump station to the wider sewerage network
- Detailed sewer design for planned developments has been completed by Western Water and will be constructed once development within the precinct commences
- A new water main along Leakes Road has been installed and currently terminates just south of the Melbourne to Ballarat Railway. Future developments within the precinct will obtain water supply from this main
- It is anticipated that the future water demand for the precinct will be supplied via a new tank at Mt Cottrell which will be constructed by Western Water once the Leakes Road main reaches capacity
- Western Water is no longer mandating recycled water to the Rockbank Town Centre. This decision has been discussed with the Victorian Planning Authority, Melton City Council and developers within the precinct
- Developers are now required to implement a water management plan in coordination with Western Water which focuses on reducing water consumption
- A new City Gate has been installed in the vicinity of the Mt Atkinson Road and Middle Road intersection however it is now anticipated that the supply for the Rockbank Town Centre will be via the existing City Gate located on Taylors Road
- A new high pressure gas main has been installed along Taylors Road which would ultimately service the Rockbank Town Centre
- NBN is responsible to service the Rockbank Town Centre with telecommunications. NBN have advised that the Government has changed the telecommunications infrastructure in new developments (TIND) policy to include infrastructure contributions which provides greater flexibility for developers
- Telecommunications supply to the Rockbank Town Centre would be via the extension of the existing distribution network if capacity permits

*This report is subject to, and must be read in conjunction with, the limitations set out in section 1.3 and the assumptions and qualifications contained throughout the Report.*

# Table of contents

1.	Introduction.....	1
1.1	Project Context .....	1
1.2	Purpose of this report.....	1
1.3	Limitations and Assumptions .....	2
2.	Sewer .....	3
2.1	2013 Spiire Sewer Summary .....	3
2.2	Current Sewer Status.....	3
3.	Potable Water .....	5
3.1	2013 Spiire Water Summary.....	5
3.2	Current Water Status .....	5
4.	Recycled Water .....	7
4.1	2013 Spiire Recycled Water Summary .....	7
4.2	Current Recycled Water Status .....	7
5.	Electrical Distribution Network .....	9
5.1	2013 Spiire Electrical Summary.....	9
5.2	Current Electrical Status .....	9
6.	Gas Distribution Network .....	11
6.1	2013 Spiire Gas Summary.....	11
6.2	Current Gas Status .....	11
7.	Telecommunications .....	12
7.1	2013 Spiire Communications Summary .....	12
7.2	Current Telecommunications Status.....	12
8.	Conclusion.....	14

## Table index

Table 1 Peer Review Findings .....	14
------------------------------------	----

## Figure index

Figure 1 Rockbank Town Centre.....	1
Figure 2 NBN committed infrastructure .....	13

# Appendices

Appendix A – Rockbank Precinct Structure Plan 1099 – Services Report

# 1. Introduction

## 1.1 Project Context

In 2013, Spiire Australia (Spiire) were engaged by the Metropolitan Planning Authority to liaise with utility providers to get an understanding of requirements for the provision of infrastructure to service the Rockbank Precinct Structure Plan (PSP). Spiire prepared a final report dated 12 November 2013, which contained information relating to the existing and proposed utility infrastructure to support the Rockbank Town Centre.

Tract Consulting has been working in partnership with Melton City Council and developers to facilitate development in the Rockbank Town Centre.

Planning for the development of the Rockbank Town Centre requires a sound understanding of existing and required utility infrastructure to support proposed demands.

The project area defined as the Rockbank Town Centre is identified in red in the map below (Figure 1).

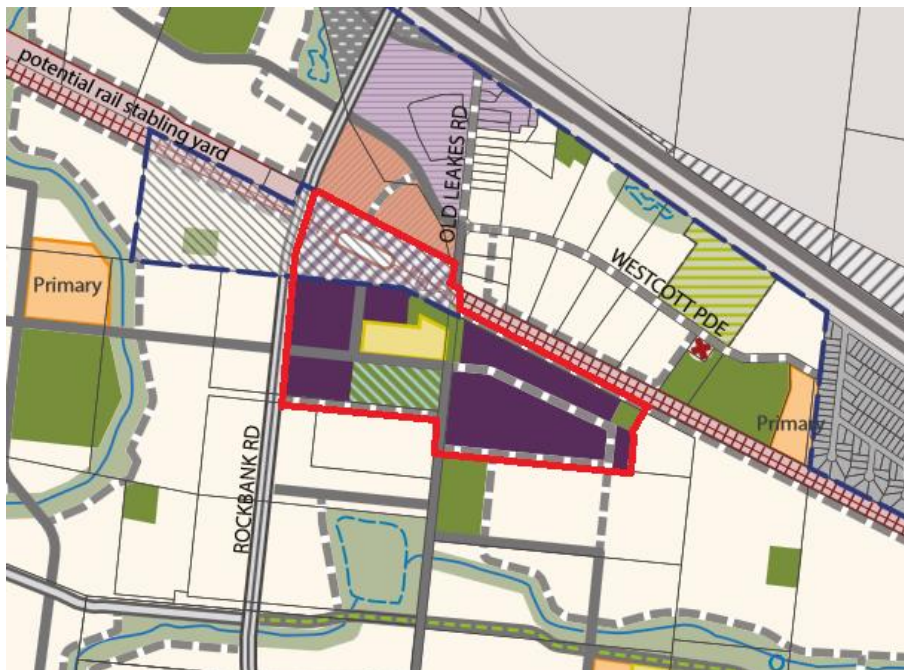

**Figure 1 Rockbank Town Centre**

## 1.2 Purpose of this report

GHD has undertaken a peer review of the *Rockbank Precinct Structure Plan 1099 Services Report* prepared by Spiire dated 12 November 2013 (Appendix A). The purpose of this peer review was to re-open the lines of communication with utility providers to confirm if the recommendations and advice documented in the Spiire Report are still valid and what changes have occurred since 2013. This report identifies the key issues, constraints and opportunities within the existing utility infrastructure network and outlines the ability of this infrastructure to accommodate the increased loads caused by development of the Rockbank Town Centre.

### **1.3 Limitations and Assumptions**

*GHD has assumed the anticipated staging and yield breakdowns contained in the Spiire Services Report are accurate and has considered/included any commercial components required as part of the Precinct Structure Plan. There would be impacts to the utility demands and potential constraints if these components were not previously considered.*

*Information provided by stakeholders is preliminary information only, is subject to change and to verification.*

*This report: has been prepared by GHD for Tract Consultants Pty Ltd and the City of Melton and may only be used and relied on by Tract Consultants Pty Ltd and the City of Melton for the purpose agreed between GHD and the Tract Consultants Pty Ltd as set out in Section 1.2 of this report.*

*GHD otherwise disclaims responsibility to any person other than Tract Consultants Pty Ltd arising in connection with this report. GHD also excludes implied warranties and conditions, to the extent legally permissible.*

*The services undertaken by GHD in connection with preparing this report were limited to those specifically detailed in the report and are subject to the scope limitations set out in the report.*

*The opinions, conclusions and any recommendations in this report are based on conditions encountered and information reviewed at the date of preparation of the report. GHD has no responsibility or obligation to update this report to account for events or changes occurring subsequent to the date that the report was prepared.*

*The opinions, conclusions and any recommendations in this report are based on assumptions made by GHD described in this report. GHD disclaims liability arising from any of the assumptions being incorrect.*

*GHD has prepared this report on the basis of information provided by Tract Consultants Pty Ltd and others who provided information to GHD (including Government authorities and utility service providers), which GHD has not independently verified or checked beyond the agreed scope of work. GHD does not accept liability in connection with such unverified information, including errors and omissions in the report which were caused by errors or omissions in that information.*

## 2. Sewer

The responsible authority for the sewerage network in the area is Western Water.

### 2.1 2013 Spiire Sewer Summary

The *Rockbank Precinct Structure Plan 1099 Services Report* prepared by Spiire dated 12 November 2013 (Appendix A) provided the following findings in relation to the sewerage network:

- The existing Rockbank Township has reticulated sewer to a small pump station located on the north western corner of the Troups Road North railway crossing. This existing pump station does not have capacity to service the Rockbank Major Town Centre
- The existing Rockbank Township will requiring connection to the new pump station as development commences throughout the PSP, at which time the existing pump station can be decommissioned
- Western Water proposed to construct a new sewer pump station north east of the Troups Road North railway crossing. This pump station will be sized to cater for a large catchment including both the Rockbank and Rockbank North PSP's with a predicted development of 40,000 new dwellings. The sewer pump station will initially be design with a capacity of 120 l/s and to cater for approximately 8,000 new dwellings. It is anticipated this infrastructure will be delivered in 2013/2014
- The new Troups Road North pump station will discharge to the Surbiton Park Recycled Water Treatment Plant via a new 375mm diameter rising main located south east of the Rockbank PSP area (totally approximately 5.1km in length). It is anticipated this infrastructure will be delivered in 2013/2014
- Branch sewers will be required throughout the Rockbank PSP which will gravitate east towards the Troups Road North pump station
- Once the new Troups Road North pump station has reach its initial capacity, the station will be augmented to increases its capacity to deliver 700 l/s and a new 700mm diameter rising main installed to discharge to the Surbiton Park Recycled Water Treatment Plant. It is anticipated these works will not occur within the first 10 years of the Troups Road North pump station becoming operational
- Western Water proposed four (4) sewer services to cross the Melbourne to Ballarat Railway and the specific locations of these crossings is subject to detailed design and approval.
- The sewer network and associated infrastructure up to and including 225mm in diameter would be developer funded. This includes but is not limited to:
  - Sewer pump stations, emergency storage and rising mains where the gravity sewer inlet to the sewer pump station is 225mm or less
  - Freehold land, reserves and or easements required to accommodate the sewer network and associated infrastructure
- Sewer infrastructure greater than 225mm in diameter will be authority funded in accordance with the adopted strategy for sequential extension of assets

### 2.2 Current Sewer Status

Western Water have advised that the information contained within the Spiire Services Report is still accurate with some changes to the existing conditions.

The Spiire Services Report indicated that Western Water intended to construct a new sewer pump station north east of the Troups Road North railway crossing. Western Water have advised that this pump station has been constructed and is called the Rockbank Sewer Pump Station. This pump station can cater for up to 5,000 lots and has capacity of 150 l/s for the Rockbank Town Centre. Once this initial capacity has been reached, the station will be augmented to increase its overall capacity.

Western Water have installed a new rising main from the Rockbank Sewer Pump Station to the Melton Recycled Water Treatment Plant. A new sewer main between Troups Road and the Rockbank Sewer Pump Station has also been installed.

Western Water have advised that no other sewerage infrastructure has commenced construction within the Rockbank Town Centre. Detailed designs have been completed to service both the Bridgefield and Hillgrove Estates, and works will commence once construction of these developments commences.



## 3. Potable Water

The responsible authority for the potable water network in the area is Western Water.

### 3.1 2013 Spiire Water Summary

The *Rockbank Precinct Structure Plan 1099 Services Report* prepared by Spiire dated 12 November 2013 (Appendix A) provided the following findings in relation to the potable water network:

- The existing Rockbank Township reticulated water system is not designed for further large scale development. Any capacity within the existing network will be depleted after the initial stages of the Rockbank North PSP are developed
- Proposed water supply for the Rockbank PSP area will be provided from the north
- A 450mm diameter water main will be installed along Leakes Road which will be used to supply the Rockbank PSP boundary. This main will travel south down Leakes Road from the Melton Highway crossing the Western Freeway. The Rockbank North PSP is the catalyst for this construction, however, it was tentatively planned for construction in 2013/2014. It is anticipated that this main will be constructed and commissioned prior to development commencing in the Rockbank PSP
- Extension of the 450mm diameter water main (as a 600mm diameter main) south down Leakes Road was not planned within the next 10 years. If the demand generated by the Rockbank PSP required the extension of this water main, Western Water would consider the benefits of bring forward the planned construction of this main
- Western Water had not accurately identified routes, alignments and constraints for the potable water network to the Rockbank PSP with the exception of the proposed 450mm diameter water main along Leakes Road. Benefits of this approach would be the locations of the water network would be flexible to suit the precinct road structure
- The potable water network and associated infrastructure up to and including 150mm in diameter would be developer funded. This includes but is not limited to:
  - Water pump stations where discharge is into a 150mm (or less) diameter water main
  - Pressure reducing valves where connected to a 150mm (or less) diameter water main
  - Water tanks with an outlet main of 150mm (or less) diameter
  - Freehold land, reserves and or easements required to accommodate the potable water network and associated infrastructure
- Western water would supply water infrastructure for assets greater than 150mm in diameter in sequence as the demand increases.

### 3.2 Current Water Status

Western Water have advised that the information contained within the Spiire Services Report is still accurate with some changes to the existing conditions and servicing strategy for the Rockbank Town Centre.

The Spiire Services Report indicated that Western Water intended to install a new water main along Leakes Road. Western Water have advised that this 450mm diameter water main has been installed and currently ends just south of the Melbourne to Ballarat Railway. It is expected that future developments within the Rockbank Town Centre would obtain supply from this water

main. Western Water have indicated that no other potable water infrastructure has been installed within the vicinity of the Town Centre.

The future water supply for the Rockbank Town Centre will be via a tank located in Mt Cottrell. The infrastructure required as part of this new supply will be constructed/installed by Western Water once the demand on the Leakes Road water main is reaching capacity.

Western Water have advised that the alignment for the future water main within the Rockbank Town Centre has been revised and is now proposed along Rockbank Road. This realignment is due to Rockbank Road being identified as the main north/south connector road. Western Water has indicated that this water main will either be a 450mm or 525mm diameter water main. This information differs from the previous Spiire Services Report as originally this water main was identified to be installed along Leakes Road, however, has now shifted further west into Rockbank Road.

## 4. Recycled Water

The responsible authority for the recycled water network in the area was previously Western Water.

### 4.1 2013 Spiire Recycled Water Summary

The *Rockbank Precinct Structure Plan 1099 Services Report* prepared by Spiire dated 12 November 2013 (Appendix A) provided the following findings in relation to the recycled water network:

- Western Water does not have ownership of any recycled water infrastructure within the Rockbank PSP
- Recycled water supply for the Rockbank PSP is from the Surbuton Recycled Water Treatment Plan located south west of the precinct
- Recycled water infrastructure will be installed along Greigs Road and Leakes Road which will supply both the Rockbank PSP and the Rockbank North PSP. Given the timing of the Rockbank North PSP, it is expected that the recycled water infrastructure will be installed in advance of development within the Rockbank PSP. This services has been designed and planned for construction in Leakes Road in 2013-2017
- The recycled water network will branch off the recycled water mains along Greigs Road and Leakes Road as required
- The recycled water network and associated infrastructure up to and including 150mm in diameter would be developer funded. This includes but is not limited to:
  - Recycled water pump stations where discharge is into a 150mm (or less) diameter recycled water main
  - Pressure reducing valves where connected to a 150mm (or less) diameter recycled water main
  - Recycled water tanks with an outlet main of 150mm (or less) diameter
  - Freehold land, reserves and or easements required to accommodate the recycled water network and associated infrastructure
- Western water would supply recycled water infrastructure for assets greater than 150mm in diameter in sequence as the demand increases.

### 4.2 Current Recycled Water Status

Western Water have advised that the information contained within the Spiire Services Report is outdated as they are no longer mandating a recycled water supply in the Rockbank PSP.

Since the Spiire Services Report was issued, Western Water have established that providing recycled water to development such as the Rockbank Town Centre is not feasible. Western Water advised that a recycled water network is an expensive way to use Class A water and they would never recover the costs that would be incurred to set up the network.

Given this information, Western Water now require developers to implement a water management plan that focuses on reducing water consumption and identifies suitable infrastructure to capture, treat and reuse water. This provides greater flexibility for developers and allows them to develop a suitable strategy..

Western Water indicated the decision to no longer mandate a recycled water network in the Rockbank PSP has been discussed with the Victoria Planning Authority (VPA) and coordinated with both Melton City Council and developers.

## 5. Electrical Distribution Network

The responsible authority for the electrical distribution network in the area is Powercor.

### 5.1 2013 Spiire Electrical Summary

The *Rockbank Precinct Structure Plan 1099 Services Report* prepared by Spiire dated 12 November 2013 (Appendix A) provided the following findings in relation to the electrical distribution network:

- Powercor advised there are no zoned substations within the Rockbank PSP. The closest zoned substation is in Melton which currently has two (2) feeders with capacity for a third. The installation of an additional feeder at the Melton zoned substation is planned to be completed within the next five (5) years
- Each 22kV feeder line can support approximately 5,000 dwellings. Given Rockbank PSP's anticipated yielding of 9,000 dwellings, supply would be via two (2) new feeder lines which are in addition to the existing feeder lines. The lead time for a new feeder line is approximately three (3) years
- The Melton zoned substation currently supplies high voltage electricity to Rockbank via a feeder line known as Melton 21. This existing supply has capacity for an additional 1,000 dwellings (approximately) after 2014. After this capacity is utilised, additional feeder lines into the Rockbank PSP will be required
- In addition to Melton 21, another high voltage service known as Melton 11 provides supply to rural customers within Rockbank. This infrastructure is insufficient to adequately support residential growth without augmentation. It is anticipated that this service will be decommissioned once the surrounding urban footprint takes in the rural properties
- Powercor are planning on constructing a new zone substation between the existing Sunshine and Melton zone substations to assist in servicing the western growth corridor. A new zone substation requires a site approximately one (1) hectare in size which has yet to be identified. Powercor do not anticipate requiring this new zone substation within the next 10 years.
- Based on current policy, Powercor is responsible to fund network development (i.e. new feeder lines, sequential extension of high voltage network etc.). Developers will be required to fund high voltage extensions if development results in out of sequence infrastructure requirements
- Powercor's policy for network development is based on a Least Cost Technically Acceptable (LCTA) solution to supply new lots. That means in most cases network development would be via overhead assets. Underground assets to suit Council or developer requirements would need to be funded by the developer

### 5.2 Current Electrical Status

Powercor have provided some preliminary feedback on the information contained within the Spiire Services Report and advised that a full internal review is still underway.

Since the Spiire Services Report was issued, Powercor have amended the funding policy where developers are responsible to fund any works required to provide additional capacity on a sole use basis. Shared use arrangements between developments are generally funded by Powercor.

Powercor advised that the standard kiosk substation reserve required for new projects has increased. The minimum land size was previously 20-30m<sup>2</sup> and has increased to 35m<sup>2</sup>. The reserves required for kiosks substations and switching cabinets must be located on either private or reserve land.

## 6. Gas Distribution Network

The responsible authority for the gas distribution network in the area is AusNet Services (AusNet).

### 6.1 2013 Spiire Gas Summary

The *Rockbank Precinct Structure Plan 1099 Services Report* prepared by Spiire dated 12 November 2013 (Appendix A) provided the following findings in relation to the gas distribution network:

- There are no transmission pipelines within the Rockbank PSP. The closest transmission pipeline is running north south along Hopkins Road located approximately 3km east of the subject site.
- AusNet advised there are no plans to extend the network to the Rockbank PSP area unless customer initiated
- The gas point of supply for the Rockbank PSP will be from either:
  - An existing City Gate located on Taylors Road approximately 6km north east of the Leakes Road interchange
  - A new City Gate located at the intersection of Mt Atkinson Road and Middle Road approximately 6.5km south east of the intersection of Troups Road North and Greigs Road (tentatively planned for construction in 2015)

### 6.2 Current Gas Status

AusNet have advised that the information contained within the Spiire Services Report is still accurate with some changes to the existing conditions and servicing strategy for the Rockbank Town Centre.

The Spiire Services Report indicated that AusNet intended to install a new City Gate near Mt Atkinson Road and Middle Road which would potentially be utilised to service the Rockbank Town Centre. AusNet have advised that this new City Gate has been installed; however, supply for the new town centre is likely to be from the existing City Gate on Taylors Road.

The installation of infrastructure to service the new Town Centre has already commenced with a new 200mm high pressure gas main installed along Taylors Road west towards Leakes Road, then south down Leakes Road to the Western Highway. It is likely that this main will extend to the Rockbank Town Centre once development commences.

# 7. Telecommunications

The responsible authority for the telecommunications in the area is NBN Co (NBN).

## 7.1 2013 Spiire Communications Summary

The *Rockbank Precinct Structure Plan 1099 Services Report* prepared by Spiire dated 12 November 2013 (Appendix A) provided the following findings in relation to the telecommunications:

- NBN is responsible to facilitate telecommunications supply to new residential estates greater than 100 lots that will be developed within three (3) years and within the NBN fibre footprint
- Developers will apply to NBN for the provision of telecommunications. The developer will then be required to design and construct a suitable pit and pipe network for NBN to utilise for the installation of telecommunications infrastructure
- Telstra is responsible to facilitate telecommunications supply to new residential estates with less than 100 lots
- There are current Telstra infrastructure/assets within the Rockbank PSP area which are currently servicing rural allotments
- NBN has not developed a strategy on how they intend to services the Rockbank PSP, however, NBN intend on using existing Telstra conduits subject to availability, location and condition
- NBN have advised there are no obstacles to the provision of telecommunications for the Rockbank PSP

## 7.2 Current Telecommunications Status

NBN have advised that this information contained within the Spiire Services Report is outdated due to Government policy changes and development applications resulting in the provision of infrastructure within the Rockbank Town Centre.

### 7.2.1 Government Policy Changes

In March 2015, the Minister for Communications released the Telecommunications infrastructure in new developments (TIND) policy, which guides how telecommunications will be delivered in new developments.

The key policy change was the introduction of infrastructure contributions to promote fairer and more effective competition, creating greater efficiency, innovation and choice.

In order to meet these requirements, NBN has introduced a number of new processes and charges to bring them in line with the policy changes, while ensuring minimal disruption to the delivery of infrastructure.

The key elements of the government policy

- Developers will continue to be able to choose carriers, including NBN, to service their developments.
- Developers will continue to meet the cost of pit and pipe.
- Developers will be required to contribute to the cost of providing telecommunications infrastructure.



- Developers will be required to provide 'fibre-ready facilities' in all new buildings, units or lots in a new real estate development
- Consistent with the NBN multi-technology mix model, NBN will be able to select the technology it will deliver to a development(s).
- NBN will work with stakeholders to simplify pit and pipe specifications (where appropriate).
- NBN can now accept applications that are less than 100 lots.

### 7.2.2 Existing Network

NBN have advised that there is a Fibre Access Node (FAN) site co-located within the Telstra Exchange in Rockbank on Old Leakes Road. Additional temporary FAN's are currently being rolled out in order to meet the high customer demand in the area.

To service new estates, supply would be via the extension of the existing distribution network if capacity exists. The blue highlighted sections in Figure 2 below indicates the existing residential areas proposed to be services by NBN in April 2018.

### 7.2.3 Proposed Network

NBN have advised that the installation of infrastructure within the Rockbank Town Centre has been committed, but is yet to be deployed. The NBN Distribution Network exists in the immediate vicinity of the town centre therefore reducing potential issues regarding servicing of the site. The green highlighted sections in Figure 2 below indicates the areas where NBN has committed to the installation of infrastructure for locations containing registered developments. These developments/estates include Bridgefield, Rockbank, 22-102 Troups Rd, and Serenity.



**Figure 2 NBN committed infrastructure**

NBN has not indicated when the network will be extended to the remainder of the Rockbank Town Centre and have advised it would have to be customer initiated and assessed on a case by case basis. New infrastructure would be deployed using a combination of NBN build, developer supplied and shared trenching arrangements.

## 8. Conclusion

This peer review of the *Rockbank Precinct Structure Plan 1099 Services Report* prepared by Spiire dated 12 November 2013 (Appendix A) provides an updated understanding as to the ability of utility infrastructure to support the projected development in the Rockbank Town Centre.

**Table 1 Peer Review Findings**

Asset	Findings
<b>Sewer</b>	<p>Western Water is the responsible authority for the sewerage network and they have advised the information in the previous services report is still accurate, with a couple of updates.</p> <p>A new sewer pump station has been constructed north east of the Troups Road North railway crossing called the Rockbank Sewer Pump Station. This new pump station can cater for up to 5,000 lots within the Rockbank Town Centre.</p> <p>New sewer infrastructure (i.e. rising mains) have been installed to connect the Rockbank Sewer Pump Station to the wider sewerage network.</p>
<b>Water</b>	<p>Western Water is the responsible authority for the potable water network and they have advised the information in the previous services report is still accurate.</p> <p>A new water main along Leakes Road has been installed which ends just south of the Melbourne to Ballarat Railway. Future developments will obtain water supply from this main.</p> <p>Once the Leakes Road water main reaches capacity, a new tank will be installed at Mt Cottrell to service the precinct.</p>
<b>Recycled Water</b>	<p>Western Water is the responsible authority for the future recycled water network, however, have advised that they will no longer mandate recycled water to the Rockbank Town Centre.</p> <p>Western Water will now require developers to implement a water management plan that focuses on reducing water consumption. This provides greater flexibility for developers.</p>
<b>Electrical</b>	<p>Powercor is the responsible authority for the electrical distribution network and have advised the previous services report is no longer accurate due to policy changes.</p> <p>Since the previous report, Powercor has changed the funding policy which requires developers to fund works for additional infrastructure for sole use. Shared use arrangements will be funded by Powercor.</p> <p>The minimum land size for a kiosk substation has increased to 35m<sup>2</sup> and is to be located on either private or reserve land.</p>
<b>Gas</b>	<p>AusNet Services is the responsible authority for the gas distribution network and have advised the previous services report is still accurate.</p> <p>A new City Gate has been installed in the vicinity of Mt Atkinson Road and Middle Road.</p> <p>Supply for the Rockbank Town Centre will be from the previously existing City Gate located on Taylors Road.</p> <p>A new high pressure gas main has been installed along Taylors Road west towards Leakes Road which will ultimately bring supply into the Rockbank Town Centre.</p>
<b>Telecommunications</b>	<p>NBN is the responsibly authority for telecommunications and have advised the previous services report is no longer accurate due to policy changes and developer applications.</p>

Since the previous report, the Government has changed the telecommunications infrastructure in new developments (TIND) policy to include infrastructure contributions.

To service the Rockbank Town Centre supply would be via the extension of an existing distribution network if capacity exists.

NBN have committed (but not deployed) telecommunications infrastructure to both existing and future residential developments within the Rockbank Town Centre. The remainder of the precinct will be rolled out once developer/customer initiated.

# Appendices

# **Appendix A** – Rockbank Precinct Structure Plan 1099 – Services Report

Prepare by Spiire Australia Pty Ltd dated 12 November 2013



**Rockbank Precinct Structure Plan 1099**  
Services Report

Prepared by **Spiire** Australia Pty Ltd  
31 May 2013

Version 4, issued 12 November 2013

Final Report

**Rockbank PSP 1099**  
Draft Services Report

**This report has been prepared by the office of Spiire**

445 Townsend Street PO Box 3400 **Albury** New South Wales 2640 Australia

**Acknowledgements and Recognition**

**Western Water**

**MWH Global for technical rail crossing advice supplied to Western Water**

**Powercor**

**SP AusNet**

**NBN Co**

Issue Date	Revision No.	Author	Checked	Approved
31 May 2013	1	Stuart Neave	Simon Eakin	Stuart Neave
5 July 2013	2	Stuart Neave		Stuart Neave
23 October 2013	3	Stuart Neave		Stuart Neave
12 November 2013	4	Stuart Neave		Stuart Neave

© Spiire

The information contained in this document is intended solely for the use of the client named for the purpose for which it has been prepared and no representation is made or is to be implied as being made to any third party. Other than for the exclusive use of the named client, no part of this report may be reproduced, stored in a retrieval system or transmitted in any form or by any means, electronic, mechanical, photocopying or otherwise, without the prior written permission of Spiire.

## Contents

1.	Introduction .....	1
1.1	Anticipated Staging and Yield .....	1
1.2	Authority Consultation .....	1
2.	Sewer .....	3
2.1	Existing infrastructure .....	3
2.2	Proposed infrastructure.....	3
2.3	Staging of infrastructure.....	4
2.4	Proposed service locations and routes .....	4
2.5	Sequential extension of services .....	6
2.6	Railway crossings .....	7
2.7	Western Water service extensions – general note .....	8
2.8	Funding arrangements.....	8
3.	Potable Water .....	9
3.1	Existing infrastructure .....	9
3.2	Proposed infrastructure.....	9
3.3	Staging of infrastructure.....	9
3.4	Proposed service locations and routes.....	9
3.5	Funding arrangements.....	10
4.	Recycled Water.....	11
4.1	Existing infrastructure .....	11
4.2	Proposed infrastructure.....	11
4.3	Staging of infrastructure.....	11
4.4	Proposed service locations and routes.....	11
4.5	Funding arrangements.....	12
5.	Electrical distribution network .....	13
5.1	Network hierarchy .....	13
5.2	Melton network.....	13
5.3	Network upgrades.....	13
5.4	Servicing the Rockbank PSP area.....	14
5.5	Funding policy .....	15
5.6	Limitations .....	15
5.7	Developer works .....	15
6.	Gas Distribution Network .....	16
6.1	Network hierarchy .....	16



6.2	Transmission Pipelines .....	16
6.3	Existing network .....	16
6.4	Proposed network upgrades .....	16
6.5	Servicing the Rockbank PSP area .....	16
6.6	Funding .....	16
<hr/>		
7.	Telecommunications .....	18
8.	Conclusion .....	19
8.1	Sewer .....	19
8.2	Potable Water .....	19
8.3	Recycled Water .....	20
8.4	Electricity .....	20
8.5	Gas .....	20
8.6	Telecommunications .....	21
<b>Appendix 1</b>	Rockbank PSP Site Plan	
<b>Appendix 2</b>	Rockbank PSP Sewer	
<b>Appendix 3</b>	Rockbank PSP Potable Water	
<b>Appendix 4</b>	Rockbank PSP Recycled Water	
<b>Appendix 5</b>	Rockbank PSP Electricity	
<b>Appendix 6</b>	Rockbank PSP Gas	
<b>Appendix 7</b>	Conceptual Section	
	MRWA W-210 Underground Crossings	

---

## 1. Introduction

Spiire Australia has been engaged by the Metropolitan Planning Authority to research and report on the provision of utility services for the Rockbank Precinct Structure Plan area (PSP).

Known as PSP 1099 in the Metropolitan Planning Authority framework, Rockbank sits within the Western Growth Corridor in the City of Melton. Rockbank is bounded by:

- The Western Freeway to the north
- Greigs Road to the south
- Paynes Road the west
- The Outer Metropolitan Ring Road transport corridor to the east
- The existing Rockbank Township adjoins the new precinct

See Appendix 1 for The Rockbank Precinct Structure Plan – site plan.

This 739 Ha PSP is identified for future urban development. The PSP is of a scale in which local and higher level facilities can be delivered to service both the existing and new communities. The PSP is expected to include a major activity area planned around the Rockbank Railway Station precinct.

The intensity of development in the PSP will be guided by the capacity of existing infrastructure, including roads and railway crossings. The report does not include commentary on road and rail capacity.

This report is limited to research on utility services including sewer, potable water, recycled water, electricity, gas and telecommunications. The report will identify the existing services within and in close proximity to the PSP and the proposed servicing arrangements for future urban development of the PSP. Integrated water management including drainage will be addressed under separate consultancy briefs.

### 1.1 Anticipated Staging and Yield

It is likely that development will be initiated on the eastern side of Leakes Road as it currently exists. It is anticipated that Leakes Road will be ultimately realigned to the west of the existing Rockbank Railway Station as an arterial road in future. The realignment is not expected for quite some time and the existing Leakes Road freeway interchange provided good road access for early development. Speculatively, “Stage 1” would occur east of Leakes Road and south of the railway expanding in an easterly direction linking with Troups Road North.

Early estimates suggest a dwelling yield of 8,500 (8,000 to 9,000) with a population of 24,000. High and medium densities are anticipated in proximity to the major town centre on near Leakes Road and Rockbank Railway Station.

This report considers servicing the entire PSP while being mindful of the anticipated need for services in this area first.

### 1.2 Authority Consultation

The following Utility Service Authorities were consulted and this report reflects their advice on existing and proposed assets to service the Rockbank PSP area.

- Western Water

- Sewer Authority
- Water Authority
- Recycled Water Authority
- Powercor
  - Electricity Distribution Network Authority
- SP AusNet
  - Gas Distribution Network Authority
- NBN Co
  - Telecommunications Authority

NBN Co has been unable to provide updated information to date. The NBN Co section in this report is based on information supplied in 2012. The information is also general in nature and not specific to this PSP.

**It should be noted that sizing and alignment of proposed services described within this report is indicative only, subject to formal offers of supply from the relevant utilities servicing agencies and detailed subdivision design.**

## Western Water

Western Water is the responsible authority for providing sewerage, water and recycled water to the Rockbank PSP area. The authority has planned for development in the Rockbank area and has supplied information for use in this report. Strategies of this nature are continually updated by Western Water as necessary. The following section consolidates information for Rockbank from Western Water's strategic plans current at the date of issue. Western Water should however be consulted regularly for updates to servicing provisions.

Due to the scale of development proposed in the region, Western Water proposes to stage the delivery of the ultimate infrastructure required and consequently will be monitoring the rate of development occurring. As required, systems will be augmented to provide additional capacity.

---

## 2. Sewer

See also Appendix 2 – Rockbank PSP Sewer.

### 2.1 Existing infrastructure

The existing Township of Rockbank has reticulated sewer to a small pump station located in the south east corner. The reticulation system and the pump station north of the railway land are not intended to service the greater precinct. From the existing pump station an existing sewer rising main traverses the precinct however this rising main will not need be retained for perpetuity. The existing township will need to be connected to a new pump station as development commences in the PSP. Upon connection to the new pump station the existing pump station and rising main can be decommissioned and will not need to be planned around.

### 2.2 Proposed infrastructure

Western Water proposes to construct a new sewer pump station on a site north of the railway line and east of Troups Road North. This pump station will be constructed initially to meet the needs of the Rockbank North PSP, north of the Western Freeway. Branch sewers will gravitate from the Rockbank North PSP under the Western Freeway to the Troups Road North pump station.

The Troups Road North pump station will ultimately be sized to cater for a large catchment including multiple precincts with a predicted development in the order of 40,000 new dwellings. Initially however it's proposed the pump station cater for approximately 8,000 new dwellings. This includes commencement within the Rockbank PSP.

The Troups Road North pump station will pump via a new rising main to the Surbiton Park Recycled Water Treatment Plant, which is south east of the Rockbank PSP area.

Branch sewers will be required within the precinct gravitating east towards the Troups Road North pump station. Although subject to detailed site analysis and design, it is expected three main branches will gravitate east and a portion of the precinct will gravitate west to Toolern. This area of the precinct is reliant on development within Toolern for provision of longer term sewer servicing. Intermediate pumping strategies can be considered.

### 2.3 Staging of infrastructure

Initially the Troups Road North pump station will have a capacity for 120 l/s and requires 5.1 km of 375mm diameter rising main to discharge effluent to the Surbiton Park Recycled Water Treatment Plant. This infrastructure is expected to be delivered in FY 2013/2014 as planned infrastructure in Water Plan 3, being the current 5 year water plan. This has been instigated by planned development in the Rockbank North PSP, accordingly this infrastructure is expected to be in place and commissioned prior to commencement of any development within the Rockbank PSP area.

Despite the Rockbank North PSP being the catalyst for planning this pump station, its construction will be demand driven. This can be from either the Rockbank North PSP or from Rockbank if it proceeds first.

Once the initial capacity of the pump station is taken up, the Troups Road North pump station will be augmented to increase its capacity to ultimately deliver 700 l/s. An additional 700mm rising main will be required to convey the additional effluent to the Surbiton Park Recycled Water Treatment Plant. The projected need for these upgrades is beyond Water Plan 4, (beyond 10 years).

The proposed gravity branch sewers within the precinct have not been prioritised in Water Plan 3. This perceived inconsistency with the proposed timing of the pump station can be explained by Rockbank North being an active PSP when Water Plan 3 was prepared versus the Rockbank PSP not being advanced at that time. Construction of branch sewers within the PSP during water plan 3 is not prohibited, however bring forward costs to assist finance these branch sewers might apply. Details of these funding arrangements are detailed further into this report.

Western Water have advised "the proposed branch sewers are outside Water Plan 3 and the timing and funding of these assets will need to be considered further".

Western Water have currently allocated the first branch sewers to Water Plan 4, i.e. beyond 5 years. Branch sewers would be extended sequentially by Western Water. Branch sewers would commence at the Troups Road North pump station and extend up the catchment as required by demand.

### 2.4 Proposed service locations and routes

The level of investigation required to accurately identify routes, alignments and constraints has not been undertaken with the exception of those pipelines proposed in Water Plan 3.

#### 2.4.1 Sewer pump station

The proposed Troups Road North sewer pump station is to be constructed on land to be commercially acquired by Western Water. The site where the proposed pump station is currently marked is approximately 4.5Ha. This is larger than necessary for Western Waters purposes. Although plans are not advanced for the facility, Western Water anticipate that an area of approximately two hectares will require a zoning PUZ1 through the PSP process. As precinct plans are developed, further consultation with Western Water is recommended to define the boundary of the proposed zoning.

#### 2.4.2 Sewer rising mains

The first of the rising mains, 375mm diameter, planned for Water Plan 3, will be constructed in existing road reserves. The rising main will exit the Wester Water site

north of the railway then head south down Troups Road North after crossing the railway. The main will then proceed west along Greigs Road along the southern boundary of the PSP.

No additional easements are required within the PSP to deal with the construction of this asset, however if the existing road reserves are removed, service corridors/easements will be necessary in their place.

The second rising main, 700mm diameter, proposed beyond Water Plan 4 may require an alternate route to Greigs Road. There will already be multiple services in Greigs Road. Greigs Road is reported to contain sensitive vegetation and also historical dry stone walls. Without the necessary detailed environmental investigations of Greigs Road, it is difficult to know how many services can be accommodated.

This main will not be constructed concurrent with earlier major services, accordingly it will require a dedicated corridor free of other services, structures, vegetation etc. A main of this size would need to be one metre clear of other services therefor requiring a dedicated 2.8m corridor. Greigs Road is a wide road reserve approximately 60m. If environmental assessments prove a 2.8m service corridor can be identified in Greigs Road, the future 700mm main could be planned for Greigs Road. This will not be known until detailed investigation are undertaken.

Alternatively, and as shown by Western Water in the attached mapping, a route through the site north of Greigs Road could be considered. This route is flexible to suit the urban framework. It is intended the future 700mm main would follow a future road reserve.

If placed in a road reserve, clearance needs to be maintained to other services. As with Greigs Road a dedicated 2.8m corridor clear of services, trees and structures in the verge would be required for its future construction. If constructed in a local street this would increase the minimum road reserve width by a similar amount. The underlying assumption in all cases is the road can be used if maintenance of the asset is required.

Final road reserve widths are dependent on detailed design, the presence of other services, drainage, landscaping, carriageway widths etc. A concept cross section for Troups Road North is attached. This has been provided to prompt discussion regarding service offsets in a tight space. This section does not consider the presence of significant vegetation or heritage items. All road cross sections are subject to detailed investigation.

An alternative to Greigs Road or a future road would be to place the future rising main in the edge of a drainage reserve. This alternative would be subject to Melbourne Water approval.

Rising mains will not be permitted in private property.

#### 2.4.3 Branch sewers

Final alignments of branch sewers are not fixed and will be influenced by the urban design. Branch sewers often follow natural depressions but would be constructed clear of any watercourse in a depression. Typically branch sewers would be at the edge of a drainage reserve within a registered easement. Alignments are flexible within the limits of gravity and cost. Typically sensitive areas can be avoided by realigning or under boring. Branch sewers may also follow streets. It is undesirable to construct branch sewers within private property.

## 2.5 Sequential extension of services

The sewer strategies outlined above rely on a logical or sequential extension of services (in this case sewer). Land ownership or other factors will influence which landholdings are development ready. There will be instances where a development is ready to commence in advance of the sequential extension of services to the boundary of the development site.

Sequential extension of services is the responsibility of Western Water under the Essential Services Commission (ESC) guidelines. Should a developer want to commence in advance of the planned infrastructure or “leap frog” another development, a request can be made for Western Water to bring forward construction. Part of the cost for these extension works would need to be funded by the developer.

The ESC is in the process of developing a new customer contributions framework for the next regulatory period. The commission have flagged this intent and has commenced consultation with industry groups but no final decision has been adopted.

The following is an extract from ESC guidance paper “New Customer Contributions” August 2012:

*Financing costs relating to bring forward connections should be calculated as financing costs on the connection capital expenditure for the number of years that the expenditure is brought forward. That is, the product of capital expenditure, the post tax nominal weighted average cost of capital and the number of years. This is a change from Water Plan 2 whereby bring forward charges were determined as 40% and 70% of construction costs depending on the bring forward category.*

*The commission requires the water corporation intending to levy the bring forward charges will have prepared up to date Development Servicing Plans that show the timing of when assets were otherwise expected to be constructed. This is because it is necessary that the water corporation be able to provide evidence that the expenditure was not otherwise planned for in the current water plan period.*

As stated above, this policy is undergoing change. Western Water has advised they are working towards posting infrastructure plans on their web site nominating the expected timing of infrastructure in accordance with the ESC guidance paper.

If bringing forward the construction of the outfall is not considered viable by either Western Water or the developer, an alternative can be temporary facilities such as pump stations and rising mains.

In the case of temporary facilities, the developer is liable for the capital cost of the temporary facility plus fees to cover operational costs over a number of years to be determined by Western Water.

Temporary pump stations are an alternative but not a given. If approved, the developer must design and construct these facilities to Western Water standards at their own expense. Temporary pumping options are also subject to lowest community cost analysis. Western Water will not support multiple temporary pump stations as might be desired from a land ownership perspective. Temporary pump stations should be designed to service a logical catchment based on topography.

## 2.6 Railway crossings

Proposed sewer services will need to cross the rail corridor. A regular V-Line service operates on this line. There are four sewer service crossings proposed, two rising mains and two gravity mains. The specific location of these crossings is subject to detailed design and approval however this section of the report will discuss requirements for rail crossings in general and will also apply to water main crossings and generally other utility crossings.

The following commentary has been provided to Western Water by their consulting Engineers MWH global for Western Water works.

*Technical requirements required to be addressed in order to obtain Victrack / Aurecon approval:*

- *Detailed Design of pipeline crossing to be undertaken in accordance with AS4799-2000 (Installation of underground utility services and pipelines within railway boundaries).*
- *WSA WAT-1213 and WAT-1214 (WSA 2002) also sets out requirements with regard to rail crossings for water mains. WSAA 2002 requires a minimum cover of 1.6m from top of railway (different to AS4799, 1.2m). Two meter clearance is generally adopted for the design. \*\**
- *Minimum horizontal clearance of 3m to any structure*
- *MSCL or PE continuously welded are acceptable carrier pipe materials under WSAA.*
- *Victrack provide an example railway crossing detailed design for guidance.*
- *Pressure pipes required to be encased.*
- *Pipeline routes, carrier pipes and encasing pipes shall be separated by a clear spacing of at least 600 mm in the horizontal plane from other pipelines*
- *Permanent pits and access chambers shall not be located within 6 m of the toe of banks or top of cuttings, nor within 10 m of the nearest rail. However, Vic Track usually require sleeving for the full length within the road reserve boundary, so valves are best placed outside this area if possible.*
- *Under WSA 2002, Class 4 RC, Mild Steel or GRP acceptable as encasing pipe material.*
- *Cathodic protection for steel pipes is an ambiguous one under the railway code and needs to be confirmed in consultation with Aurecon.*
- *WSA 2002 states "provide stray current protection as directed by railway authority". The retailer version of WSA 2002 requires cathodic protection generally for any steel pipeline longer than 10m. MRWA (WSA 03) drawings require cathodically protected steel pipelines.*
- *Standard Marker posts are required*
- *Unsupported boreholes are not Victracks preference (i.e. encasing pipe required to be progressively advanced during drilling), but I understand there are cases where they have accepted unsupported borehole installations.*

\*\*The Melbourne Retail Water Agency (MRWA) water supply standard drawings provide a visual description of Railway Service crossings. Western Water are not included in the MRWA so this drawing is provided as a guide only. As stated above designs are to be in accordance with AS 4799 and WSAA.



Service crossings should be planned to cross at 90 degrees to the railway line. It is recommended that proposed crossing points are planned with this in mind. In total there are six proposed railway crossings for major water authority assets. There are two sewer rising mains in the vicinity of Troups Road North, one branch sewer near Troups Road North and another at the western corner of the Rockbank Township. There is also a potable trunk main and recycled water trunk main crossing the railway in Leakes Road.

If the railway line is to remain in operation, these services should be designed to be under bored and sleeved in accordance with the technical requirements outlined above.

When development within the PSP commences four of the six trunk services will be required; two water mains in Leakes Road and a branch sewer and rising main in Troups Road North. If construction of all four services warranted a shutdown of the railway, consideration should be given to installing the further two crossings at this time. Furthermore the rail corridor is planned to expand, the proposed crossings should consider this future expansion and material selection for crossing under the railway should be extended for the full 40m corridor.

A construction feasibility of these major crossings would be required to determine the optimum construction method. Given the size of the initial pressure services three separate under bores would seem appropriate. The branch sewer will be quite deep and this could be bored or tunnelled depending on the ground conditions.

Other utility crossings will be required however the conduit size for these services is smaller than the water authority assets.

## **2.7 Western Water service extensions – general note**

Western Water will only extend services as development requires. Services will not be extended into new areas based on development speculation.

## **2.8 Funding arrangements**

Reticulation assets will be developer funded. In the case of sewer, a reticulation asset is defined as “a gravity sewerage main that is 225mm or less in diameter and all associated assets”. It is to be fully funded by the developer and vested to the water corporation, regardless of whether it is required to be sized or positioned to service other developments.

*Associated assets* are deemed to be reticulation assets including, but not limited to:

- Sewer pump stations, emergency storage and rising mains (where the gravity sewer inlet to the sewer pump station is less than or equal to 225mm diameter)
- Freehold land, reserves and or easements required to accommodate reticulation assets.

Assets larger than reticulation assets will be authority funded in accordance with the adopted strategy for sequential extension of assets.

---

### **3. Potable Water**

See also Appendix 3 – Rockbank PSP Potable Water.

#### **3.1 Existing infrastructure**

The existing Rockbank Township has reticulated water as do the surrounding rural allotments in the Rockbank Precinct. This reticulation system is not designed for further large scale development. As development progresses supply will need to be maintained to rural properties. As these rural properties are taken in by the expanding urban footprint the existing services will be replaced by a suitable network to service urban development.

Although shown indicatively as “existing” on Attachment 3, there is no existing water infrastructure that needs to be planned around within the precinct.

#### **3.2 Proposed infrastructure**

Any capacity in the existing network that supplies the Rockbank Township from Melton is expected to be depleted after servicing the initial stages of the Rockbank North PSP.

The proposed permanent water supply for the Rockbank PSP area has been designed and will be provided from the north. A 450mm diameter pipeline is proposed for Leakes Road. This main will travel from the Melton Highway south down Leakes Road crossing the Western Freeway. The proposed main is currently designed to terminate north of the railway line however Western Water are considering extending this service under the rail corridor.

This 450mm service is planned for 2013/2014 as part of Water Plan 3. Proposed development in the Rockbank North PSP is the catalyst for this service. It is predicted that this service will be constructed and commissioned prior to development within the Rockbank PSP area.

In the event that the Rockbank North PSP does not develop within Water Plan 3, the service could still be constructed if there was development demand in Rockbank.

#### **3.3 Staging of infrastructure**

The 450mm diameter service in Leakes Road will bring suitable supply to the precinct boundary. Extension of this main south down Leakes Road is not included in Water Plan 3 or Water Plan 4, the current or successive Water Plans. Western Water are not programming for this extension (600mm diameter) in the next 10 years. Given there is good freeway access to Leakes Road via the interchange, it is expected early development within the precinct could occur in Leakes Road. If there is demand in this area, Western Water will consider the benefits of bringing forward the planned construction of this extension.

#### **3.4 Proposed service locations and routes**

The level of investigation required to accurately identify routes, alignments and constraints has not been undertaken with the exception of those pipelines proposed in Water Plan 3.

With the exception of major pipe tracks, water mains will generally follow road reserves. There is flexibility in the location of mains to accommodate urban design. Utilising the closest available roads to the strategic route would be desirable for larger mains to minimise cost.

As the trunk water main south of the Western Freeway mooted for Leakes Road is not in a current Water Plan, the location for this service is flexible to suit the precinct road structure. If accommodated in a road reserve one metre clearance to adjoining services either side of the main should be allocated. This may need to be increased or a vertical separation to adjoining parallel services be introduced where offtakes from the main are required.

The design of services needs to consider minimum cover under proposed roads and clearances to gravity services. As a water system is pressurised, there is flexibility to manoeuvre pipes vertically to avoid underground clashes provided cover is maintained.

Pressure services will not be permitted through easements in private property. However during development there might be cause to consider constructing services in advance of roads. This is not preferred by Western Water but will be considered if there is appropriate detail on future road levels and position. Planning controls would also be required such as a Public Acquisition Overlay (PAO) over the route. There has been some discussion around realigning Leakes Road to the west. It would be possible to plan trunk water services in this route however they would be best built when the road is realigned which will most likely not coincide with the need for the services. If the services are constructed in isolation through a PAO they may become landlocked. The cleaner approach is to use Leakes Road.

It's predicted that the early stages to be constructed are east of Leakes Road as it currently exists. It's reasonable to assume that a major water service will be required in the existing Leakes Road road reserve. Western Water will assess if the ultimate trunk service is warranted or a smaller main to facilitate early development.

### **3.5 Funding arrangements**

Reticulation services up to and including 150mm in diameter and associated assets will be developer funded.

Associated assets are deemed to be reticulation assets including, but not limited to:

- Water pump stations where the pump discharges into water mains of 150mm diameter or less
- Pressure reducing valves where connected to water mains of 150mm diameter or less
- Water tanks where the outlet main is 150mm diameter or less
- Freehold land, reserves and or easements required to accommodate reticulation assets.

Water services greater than 150mm will be supplied by Western Water in sequence as demand increases. Bring forward costs for out of sequence works will apply. Tariffs or headworks charges as determined by Western Water and or the Essential Services Commission will be applicable for development in the precinct.

---

#### **4. Recycled Water**

See also Appendix 4 – Rockbank PSP Recycled Water.

##### **4.1 Existing infrastructure**

There is no existing recycled water within the precinct in the control of Western Water.

##### **4.2 Proposed infrastructure**

Recycled water is proposed and will be supplied from the Surbiton Park Recycled Water Treatment Plant, south west of the precinct. Recycled water will be supplied via a pipeline in Greigs Road and Leakes Road. This service is also required to supply recycled water to the Rockbank North PSP. Accordingly it is expected this pipeline will be constructed in advance of any works within the Rockbank PSP area.

This service has already been designed and is planned for construction in Leakes Road in Water Plan 3. Construction of this main in Leakes Road will introduce a constraint to be planned around in the urban design.

As with the potable service, alternate routes have been considered, i.e. future Leakes Road. In this case, the pipeline is expected to be required before the necessary planning controls could be introduced. A route along an existing road reserves is desirable.

##### **4.3 Staging of infrastructure**

The recycled water network branching off the main trunk will be planned as required. Western Water have indicated that should there be any delays in providing trunk recycled water, reticulation services will need to be constructed with temporary cross connections to the potable supply network.

##### **4.4 Proposed service locations and routes**

With the exception of major pipe tracks, water mains will generally follow road reserves. There is flexibility in the location of mains to accommodate urban design. Utilising the closest available roads to the strategic route would be desirable for larger mains to minimise cost.

The proposed Leakes Road supply main is already designed. Future services will need to be designed clear of this main. One metre clearance to adjoining services either side of the main should be allocated. This may need to be increased or a vertical separation to adjoining parallel services be introduced where offtakes from the main are required.

The recycled water main is the only service proposed for delivery in Leakes Road in Water Plan 3. It is therefore the only service designed. Design investigations have taken place for this service but not for future services which might wish to occupy space within the same road reserve. Detailed investigations including environmental and heritage assessments together with engineering design for offtakes will need to be undertaken to determine final service alignments in Leakes Road.

The design of services needs to consider minimum cover under proposed roads and clearances to gravity services. As a water system is pressurised, there is flexibility to manoeuvre pipes vertically to avoid underground clashes provided cover is maintained.

Pressure services will not be permitted through easements in private property.

#### **4.5 Funding arrangements**

Reticulation services up to and including 150mm in diameter and associated assets will be developer funded.

Associated assets are deemed to be reticulation assets including, but not limited to:

- Waste water pump stations where the pump discharges into waste water mains of 150mm diameter or less
- Pressure reducing valves where connected to waste water mains of 150mm diameter or less
- Waste water tanks where the outlet main is 150mm diameter or less
- Freehold land, reserves and or easements required to accommodate reticulation assets.

Recycled Water Services greater than 150mm will be supplied by Western Water in sequence as demand increases. Tariffs or headworks charges as determined by Western Water and or the essential services commission will be applicable for development in the precinct.

Bring forward costs for out of sequence works would not be applicable to extend waste water infrastructure if temporary cross connections to the potable system are available.

## Powercor

Electricity conductors (power lines) are often categorised into two groups, the electricity transmission network and the electricity distribution network. The transmission network is regarded as 220+ kilovolt (kV), usually identified by large steel trussed towers supporting the conductors. The distribution network is 66kV and below. Usually these conductors are supported on conventional poles or installed underground. Powercor is the responsible authority for the distribution network within the region encompassing the Rockbank PSP.

---

## 5. Electrical distribution network

See also Appendix 5 – Rockbank PSP Electrical Network.

### 5.1 Network hierarchy

The following is the hierarchy of the electrical network:

- Power generation
- Transmission lines 220+ kilo volt (kV)
- Terminal Substation, 220kV - 66kV
- Distribution lines, 66kV
- Zoned Substation, 66kV – 22kV
- HV lines – 22kV
- Kiosk or pole mounted substation 22kV – 415/240V low voltage

For the purpose of this report, we need only be interested in the distribution network and in particular the 22kV high voltage feeder lines from zoned substations. Supply for residential estates is obtained from these lines and is then transformed to low voltage at kiosks throughout the developments.

### 5.2 Melton network

There is a zoned substation in Melton which currently has two transformers with the ability to house a third. Each transformer supplies four 22kV feeder lines each with a conducting capacity of 12 mega volt ampere (MVA). MVA is a measure of power, more specifically voltage multiplied by current. One 22kV feeder line can support approximately 5000 customers.

*“A dwelling yield of 9000 lots equates to approximately 21MVA of new load. This would need to be supplied by 2 new 22kV feeders”* in addition to existing feeders outlined below.

### 5.3 Network upgrades

There are plans to include a third transformer at Melton in the next 5 years. Powercor are also planning to construct a new zone substation between the existing zones of Sunshine and Melton to assist in servicing the western growth corridor. A site for the new zoned substation has not been selected. An acquisition will be required in time but Powercor do not anticipate requiring the new zoned substation inside 10 years.

When required, the new zoned substation will require a site one hectare in size. This would be acquired by Powercor under commercial arrangements.

*“Timing for a third transformer at zone substation Melton and for the eventuality of a new zone substation between Sunshine and Melton depends on load, load at risk, load growth, hours at risk of overload, budgetary, labour and plant/material constraints etc. These two project timelines are not locked in.”*

The zoned substations are connected by 66kV distribution lines. Preliminary proposals are to route this 66kV line along the Western Freeway. It is not proposed to traverse development land at this stage so setting aside corridors or easements is premature.

*“Whether or not there are easements or corridors to be provisioned, is unknown at this stage”.*

The Melton zoned substation currently supplies 22kV high voltage electricity to Rockbank. A 22kV feeder line known as Melton 21 runs in the central median of the Western Freeway. Predictions suggest Melton 21 will only have capacity for approximately 1000 new customers after 2014. Plans for additional 22kV feeder lines need to be made as the approximate lead time to bring a new line of this type into service is approximately three years.

*“All forecast loads provided are just that, and subject to change without any prior notice”.*

In addition to Melton 21, the Rockbank PSP area is serviced by Melton 11. Melton 11 is a high voltage service in Greigs Road but is not adequate to supply development without augmentation. Melton 11 is structured to service rural customers. The conductors are not adequate to support residential growth. Augmentation of this system would in part be the responsibility of Powercor, however should a development front commence in the south west corner of the PSP, the developer would need to fund 2.2 km of overhead high voltage upgrades from the corner of Mt Cottrell Road and Harrison Road to the corner of Paynes Road and Greigs Road. Subject to the customer contributions policy.

*“Should a development front commence in the South-West corner of the attached PSP, the developer may need to fund:*

- a) *5 km of new line and upgrades from steel*

Powercor have been queried on this point. The last 2.2 km (approx.) will need to be developer funded as its single phase and upgrades are required to service developer needs. The first 2.8 km (approx.) is three phase and Powercor have previously advised this upgrade would be their responsibility.

- b) *A protection study/implementation of HV fusing / Automatic Circuit Recloser (ACRs)”.*

#### **5.4 Servicing the Rockbank PSP area**

There is existing High Voltage overhead supply in Leakes Road. This system has capacity to initially develop approximately 130 lots. Following this, Powercor will need to upgrade this service back to the Western Freeway.

*“The existing HV Overhead supply in Leakes Rd comprises of a combination of single-phase and three-phase Steel conductor.*

*Additional load cannot be connected onto this network without prior augmentation works. This includes a protection study / implementation of HV fusing / ACRs. The developer must fund this.”*

## 5.5 Funding policy

Under Powercor's current policy, they are responsible for network development, i.e. new feeders and sequential extension of high voltage networks. Developers would only fund high voltage extensions if out of sequence. The developer is responsible for internal network constructions, including underground high and low voltage works with rebates for works as relevant at the time of extension agreements with Powercor.

Network extensions that are the responsibility of Powercor are provided on the basis of least cost technically acceptable solutions. That means in most cases extensions would be overhead, while undergrounding to suit Council or developer requirements would need to be funded by the developer.

Powercor's policy is to determine the Least Cost Technically Acceptable (LCTA) solution for supply to the new lots. Tapping a new underground line off an existing overhead line for supply into a development is LCTA. Converting the adjacent existing overhead line to underground is additional work over and above. The developer requiring the underground conversion is responsible for the full cost of this additional work.

New underground HV assets installed within a residential development, expressly for provision of supply to the development lots, are considered LCTA. Conversion of any existing overhead assets to underground is generally charged at direct cost to the developer, as this work is not required for supply to the new load.

Installation of underground HV cable as part of the supply reticulation for new load is considered part of the LCTA and is modelled as per our usual customer contribution calculations. Powercor would not install overhead HV for supply to new lots.

## 5.6 Limitations

No supply limitations have been identified provided network upgrades are programmed and undertaken as described above. Existing overhead supply to rural properties is expected to be decommissioned as the urban footprint takes in rural properties. Any existing minor easements will be extinguished in this process.

## 5.7 Developer works

All new networks 22kV and below will need to be underground networks.

No additional buffers over and above easements or road reserves will be required for existing lines. Kiosk substations will be required throughout the precinct. Land allocations for these would not be made until planning permit stage based on a reasonably detailed electrical network design. Kiosk substations require very little land, 20 – 30 m<sup>2</sup> and are usually accommodated in open space adjoining roads. There is no need quarantine specific parcels of land to accommodate Kiosks substations in planning the PSP.



## SP AusNet

SP AusNet is the responsible authority for gas distribution networks in this region.

---

### 6. Gas Distribution Network

See also Appendix 6 – Rockbank PSP Gas

#### 6.1 Network hierarchy

The overall gas network includes transmission pipelines and the distribution network. Transmission pipelines run at high pressure, 10,000 KPa and move large volumes of gas around the state and beyond. The transmission network does not directly supply consumers. The distribution network operates at a lower pressure of 550 KPa. The distribution network is connected to the transmission network at strategic locations and ultimately serves consumers. Connecting the distribution network to transmission pipelines requires a pressure reducing facility known as a City Gate.

#### 6.2 Transmission Pipelines

There are no transmission pipelines within the PSP. The closest transmission pipeline is approximately three kilometres away running north south along Hopkins Road.

#### 6.3 Existing network

Typically supply to new estates would be via the extension of an existing distribution network if capacity exists. SP AusNet has advised no network exists in the immediate vicinity of the PSP. The closest point of supply for Rockbank is the existing City Gate in Taylors Road approximately 6km north east of the Leakes Road interchange.

#### 6.4 Proposed network upgrades

SP AusNet has advised there are no plans to extend the network to the Rockbank PSP area unless customer initiated.

There is a proposal for SP AusNet to install a new City Gate in the vicinity of Mt Atkinson Road and Middle Road. This is approximately 6.5km south east of the intersection of Troups Road North and Greigs Road. Tentatively planned for 2015 this could be an alternate point of supply for the Rockbank PSP area.

The existing transmission line in Hopkins Road presents potential opportunity for alternate sites for a City Gate closer to the Rockbank PSP. Alternate sites along Hopkins Road have not been considered or reviewed by SP AusNet at present.

#### 6.5 Servicing the Rockbank PSP area

Both points of supply nominated by SP AusNet require significant pipelines to service the PSP. SP AusNet have identified that there are no plans for extension of the existing network unless customer initiated.

The Rockbank North PSP has been approved however no agreement has been reached with SP AusNet to extend services along Taylors Road to service the Rockbank North PSP.

#### 6.6 Funding

Gas is not considered an essential service and supply of gas to an estate needs to be commercially viable or otherwise subsidised. Typically the distribution network operator would forecast revenue from a growth area and undertake a cost benefit analysis to

establish the commercial viability of providing the service. If the return does not warrant the expense, the service would only be provided if subsidised by the customer, in this case part or wholly developer funded main extensions. Subject to ongoing cost benefit analysis the distribution network operator would usually provide internal gas reticulation in new estates if the distribution network is sequentially extended as development progresses.

---

## 7. Telecommunications

NBN Co is the responsible agency for the delivery of the National Broadband Network (NBN). Telecommunication design and installation in all new residential estates greater than 100 lots that will be developed within three years and within the NBNCo fibre footprint, will be administered through the NBN Co system. Developers will need to make application to NBN Co for the provision of telecommunications. The developer will then need to design and construct a suitable pit and pipe network for NBN to utilise.

NBN Co has advised there are no obstacles to the provision of telecommunications for the precinct.

For development less than 100 lots, developers will be directed to make application through Telstra. Developers will be required to construct a pit and pipe network for Telstra and future fibre requirements.

Telstra are no longer responsible for the supply of new networks although their existing infrastructure will continue to be utilised while required. There are current Telstra assets within the Rockbank PSP area. These are generally services to rural allotments.

NBN Co has not planned how the network will roll out across the Rockbank Precinct. NBN Co will use existing Telstra conduits subject to availability, location and condition.

Should development require removal of existing road reservations containing Telstra assets, further enquiries with Telstra will be required regarding relocation of existing assets. Furthermore developers should also undertake a dial before you dig enquiry before commencing any works on their property.

For further information visit:

<http://www.nbnco.com.au/industry/new-developments/new-developments-policy-information.html>

---

## **8. Conclusion**

### **8.1 Sewer**

Western Water is the responsible authority for sewer.

There is not sewer currently available at the PSP boundary.

The PSP predominantly gravitates to the north east. Sewer will be provided by Western Water via the construction of a new pump station east of Troups Road North. This pump station is planned for 2013 – 2014 and is expected to be commissioned prior to development in the PSP.

The pump station will be staged to accommodate increasing development. Stage 1 of the pump station will include pumps and a rising main suitable to cater for 8000 new dwellings.

The Stage 1 rising main (375mm in diameter) will discharge to the Surbiton Park Recycled Water Treatment Plant and will be constructed in Troups Road North and Greigs Road.

Subsequent upgrades to the Troups Road North pump station will require an additional 700mm diameter rising main. It is expected this rising main will need to traverse the PSP and should be contained in a road reserve, pipe track or public reserve. If accommodated in a road reserve an additional 2.8 metres will be required in the nature strip dedicated to this service. If a dedicated pipe track is reserved this should be 10 metres wide.

The Troups Road North pump station will require PUZ1 zoning and will be approximately 2 hectares in size. Western Water should be contacted for specifics as the precinct plans develop.

Branch sewers will need to be constructed from the Troups Road North pump station west into the PSP area.

A small section in the north west corner of the PSP falls within a different catchment. This area will be ultimately served with sewer from the Toolern PSP when available.

Final alignments of the branch sewers are not fixed and will be influenced by the urban design.

Reticulation services 225mm and below shall be developer designed, constructed, funded and vested with Western Water. Services larger than 225mm diameter are funded by Western Water.

Out of sequence developments may need to be serviced by temporary sewer options in the first instance and may attract “bring forward” charges for developers.

### **8.2 Potable Water**

Western Water is the responsible authority for potable water.

Reticulated water exists in the PSP area however this network is suitable only to service the farms and Rockbank Township. A new potable water trunk main needs to be delivered to the PSP boundary to service future development.

Western Water propose to service the PSP with a 450mm diameter water main to be constructed in Leakes Road north of the Western Freeway terminating south of the

Western Freeway. This main is currently designed to terminate just north of the railway line, however Western Water will consider the merits of extending the main under the railway. No commitments have been made at this stage as this would be a departure from Water Plan 3.

The 450mm potable water main is proposed to be constructed in 2013 – 2014 and is expected to be commissioned prior to development within the PSP.

Forward plans are to extend this service further south in the vicinity of Leakes Road. The alignment is flexible to match the precinct design.

Assuming the service will be constructed in a road reserve, one metre clearance to other services should be allocated either side of the main.

Reticulation services 150mm and below shall be developer designed, constructed, funded and vested with Western Water. Services larger than 150mm diameter are funded by Western Water.

Out of sequence developments may need to be serviced by extending infrastructure and will attract “bring forward” charges for developers.

### **8.3 Recycled Water**

Western Water is the responsible authority for recycled water.

Western Water intends to supply the Rockbank PSP with recycled water.

The PSP is expected to be serviced from the Surbiton Park Recycled Water Treatment Plant via a pipeline to be constructed in Greigs Road and Leakes Road.

The recycled water pipeline is expected to be constructed to service the Rockbank North PSP in advance of the Rockbank PSP developing. Should this service be constructed in Leakes Road this will provide a constraint to plan around.

Western Water may allow temporary cross connection to the potable water network in the event the trunk service is not available for connection.

### **8.4 Electricity**

Powercor are the responsible authority for power distribution.

There are existing High Voltage 22kV feeder lines in the Western Freeway capable of providing supply to the PSP.

Powercor propose to augment the high voltage network as required to service the PSP. Upgrades specific for development that are not considered network upgrades will need to be developer funded

Developers will need to fund internal works.

Developers would need to pay for undergrounding existing overhead lines if desired. Developers would also need to pay additional costs to underground new high voltage works if the least cost technically acceptable solution is over head.

There are no electricity supply limitations relating to the future development of the Rockbank PSP area.

### **8.5 Gas**

SP AusNet is the responsible authority for gas distribution.

The point of supply for the Rockbank PSP is approximately 6km north west at the Taylors Road City Gate. A City Gate is a facility to reduce the pressure at off take from the gas transmission network.

SP AusNet has advised there are no plans to extend the network to the Rockbank PSP area unless customer initiated.

There is a proposal for SP AusNet to install a new City Gate in the vicinity of Mt Atkinson Road and Middle Road. This is approximately 6.5km south east of the intersection of Troups Road North and Greigs Road. Tentatively planned for 2015 this could be an alternate point of supply for the Rockbank PSP area.

## **8.6 Telecommunications**

There are no obstacles to the provision of telecommunications for the precinct.

**Rockbank PSP 1099**  
Draft Services Report



**Appendix 1**  
Rockbank PSP Site Plan

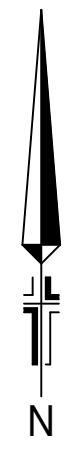

Legend

 Precinct boundary

Precinct Plan  
Rockbank  
Site Plan

Co-ordinate Datum  
MGA55

Scale A3  
1 : 40000

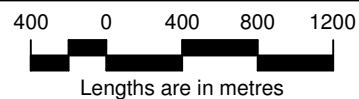

Date	4/6/2013	Sheet	1 of 1
Drawing No.	139029P00 SITE	Version	1
CAD Ref.	E:\JOBS\1009 ROCKBANK PSP\CAD FILES\ACAD		
Drawn By	ES	Checked By	SN
REV	AMENDMENT	APPROVED	DATE



445 Townsend Street  
PO Box 3400  
Albury NSW 2640  
T 61 2 6051 1300  
spiire.com.au



**Rockbank PSP 1099**  
Draft Services Report



**Appendix 2**  
Rockbank PSP Sewer

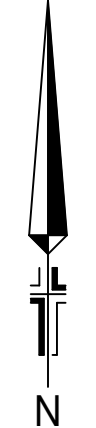
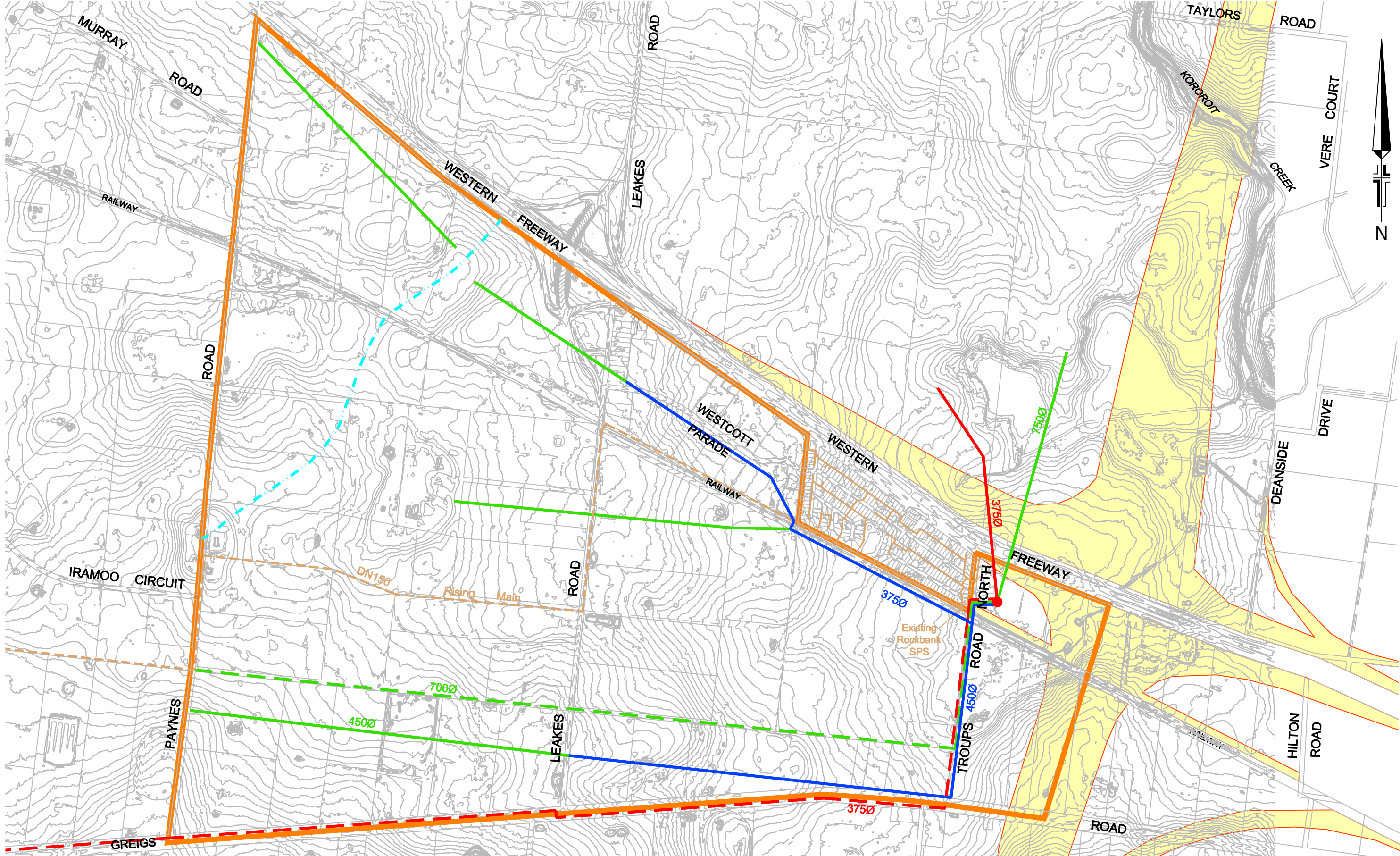

- Legend**
- Precinct boundary
  - Existing Sewer / Rising Main / Pump Station
  - WP3 Sewer / Rising Main / Pump Station
  - WP4 Sewer / Rising Main
  - Future Sewer / Rising Main
  - Approximate Catchment Boundary

Note : Contour Interval 0.5m

**Precinct Plan  
Rockbank  
Indicative Sewer Layout**

Co-ordinate Datum MGA55	Scale A3 1 : 15000	<p>Lengths are in metres</p>
----------------------------	-----------------------	------------------------------

Date	30/4/2013	Sheet	1 of 1
Drawing No.	139029P00 SEWER	Version	2
CAD Ref.	E:\JOBS\1009 ROCKBANK PSPICAD FILES\ACAD		
Drawn By	ES	Checked By	SN
2	Indicative alignment amendments	S.N.	15-09-2013
REV	AMENDMENT	APPROVED	DATE



445 Townsend Street  
PO Box 3400  
Albury NSW 2640  
T 61 2 6051 1300  
spiire.com.au

**Rockbank PSP 1099**  
Draft Services Report



**Appendix 3**  
Rockbank PSP Potable Water

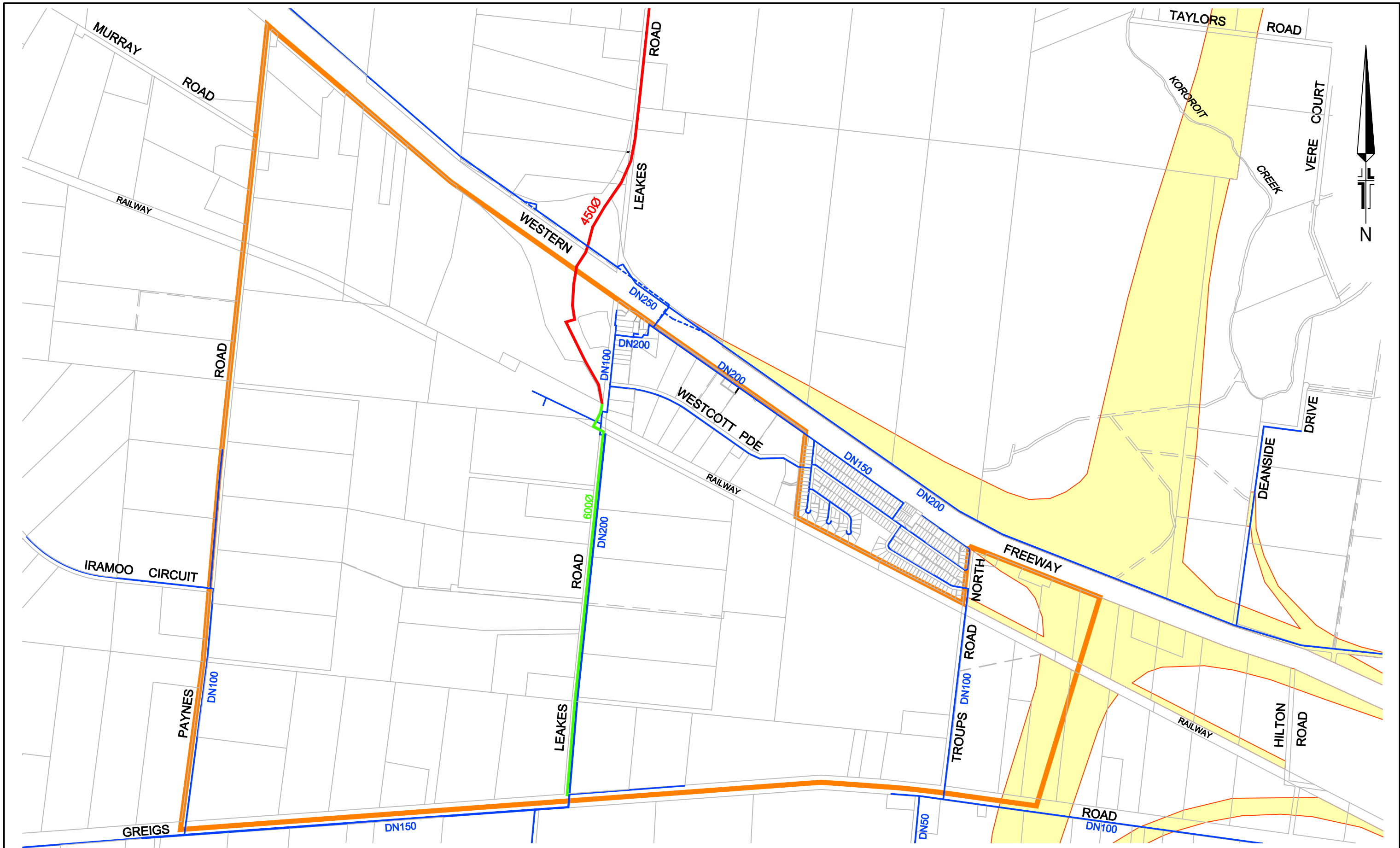

**Legend**

- Precinct boundary
- Existing Water Main
- Proposed Trunk Water (WP3 2013-2017)
- Proposed Trunk Water (WP5 2023-2027 or beyond)

**Precinct Plan  
Rockbank  
Indicative Potable Water Layout**

Co-ordinate Datum  
MGA55

Scale A3  
1 : 15000

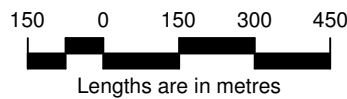

Date	30/4/2013	Sheet	1 of 1
Drawing No.	139029P00 WATER	Version	2
CAD Ref.	E:\JOBS\1009 ROCKBANK PSP\CAD FILES\ACAD		
Drawn By	ES	Checked By	SN
2	Update legend and extent of WP3 works	S.N.	16-09-2013
REV	AMENDMENT	APPROVED	DATE



445 Townsend Street  
PO Box 3400  
Albury NSW 2640  
T 61 2 6051 1300  
spiire.com.au

**Rockbank PSP 1099**  
Draft Services Report



**Appendix 4**  
Rockbank PSP Recycled Water

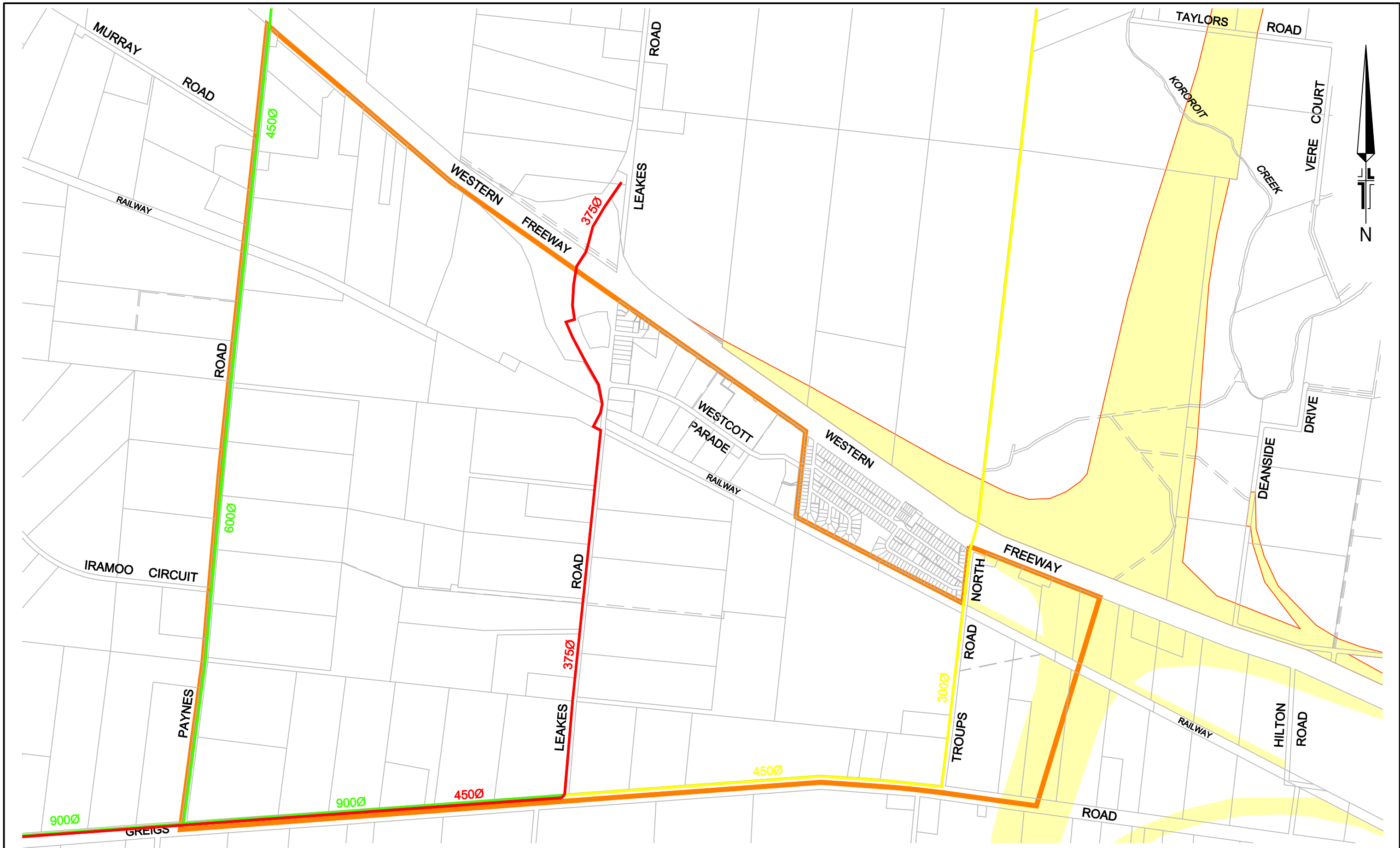

- Legend
- Precinct boundary
  - Proposed Trunk Recycled Water (WP3 2013-2017)
  - Proposed Trunk Recycled Water (WP4 2018-2023)
  - Proposed Trunk Recycled Water (Beyond WP4)

**Precinct Plan  
Rockbank  
Indicative Recycled Water Layout**

Co-ordinate Datum: MGA55  
Scale: A3  
1 : 15000

Lengths are in metres

Date	30/4/2013	Sheet	1 of 1
Drawing No.	139029P00 RECYCLED WATER	Version	2
CAD Ref.	E:\JOBS\1009 ROCKBANK PSPICAD FILES\ACAD		
Drawn By	ES	Checked By	SN
2	Legend updated future services added	S.N.	15-09-2013
REV	AMENDMENT	APPROVED	DATE

445 Townsend Street  
PO Box 3400  
Albury NSW 2640  
T 61 2 6051 1300  
spiire.com.au

**Rockbank PSP 1099**  
Draft Services Report



**Appendix 5**  
Rockbank PSP Electricity

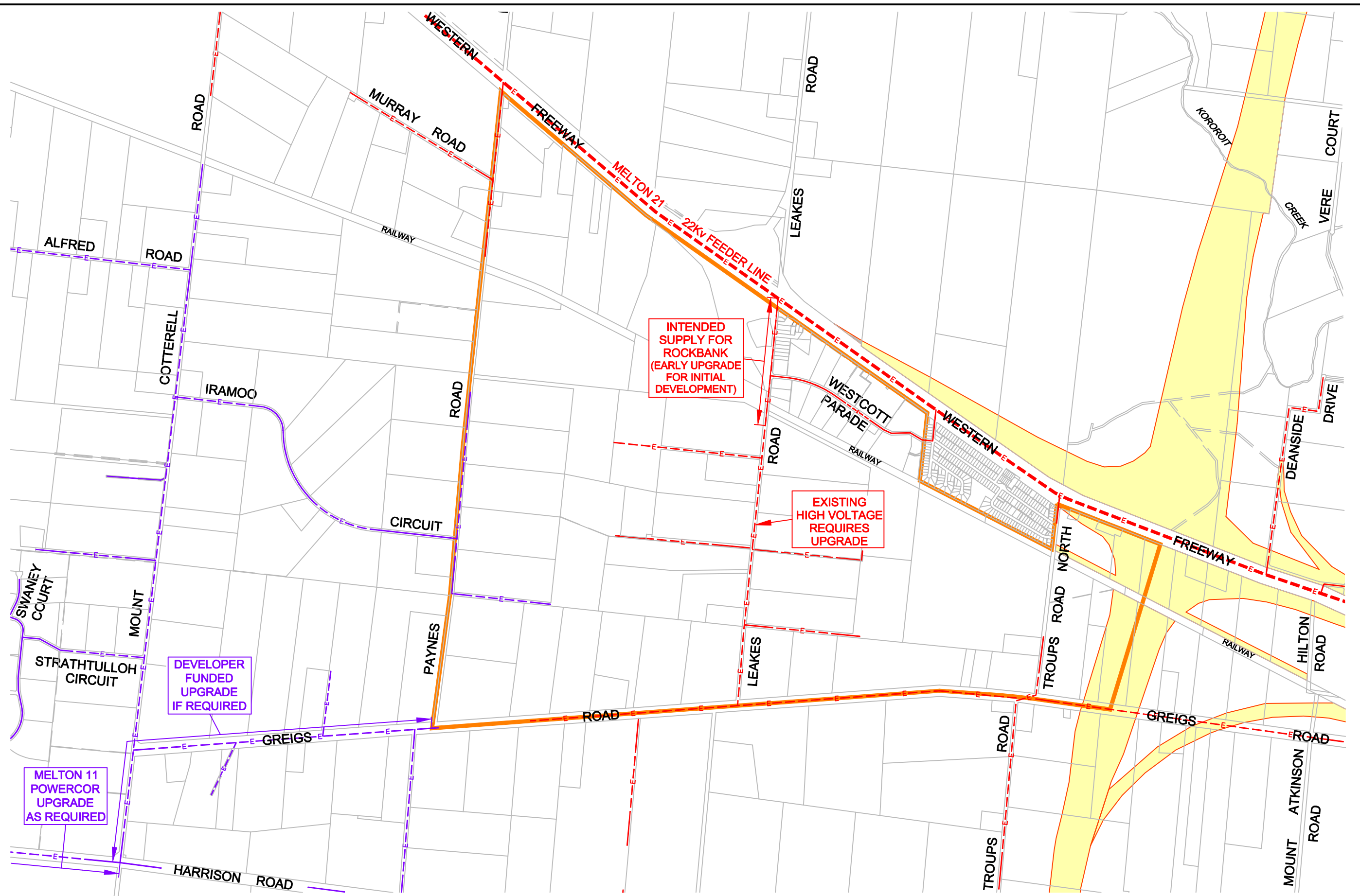

- Legend**
- Precinct boundary
  - Melton 11 System
  - Melton 21 System

**Precinct Plan  
Rockbank  
Indicative Electrical Layout**

Co-ordinate Datum MGA55	Scale A3 1 : 20000	<p>200 0 200 400 600 Lengths are in metres</p>
----------------------------	--------------------------	--

Date	15/5/2013	Sheet	1 of 1
Drawing No.	139029P00 ELECTRICITY	Version	1
CAD Ref.	E:\JOBS\1009 ROCKBANK PSP\CAD FILES\ACAD		
Drawn By	ES	Checked By	SN
REV	AMENDMENT	APPROVED	DATE



445 Townsend Street  
PO Box 3400  
Albury NSW 2640  
T 61 2 6051 1300  
spiire.com.au



**Rockbank PSP 1099**  
Draft Services Report



**Appendix 6**  
Rockbank PSP Gas

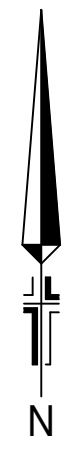
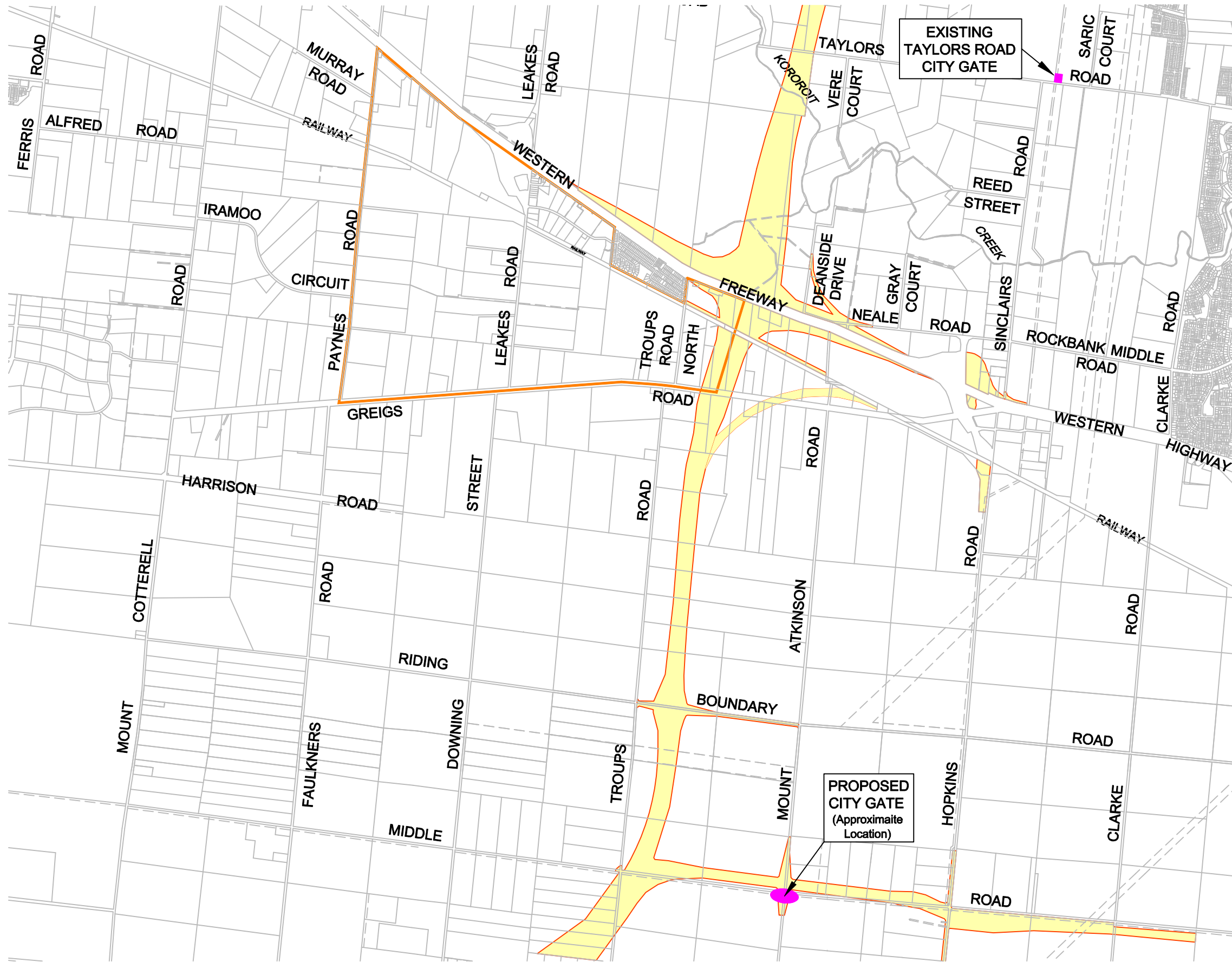

Legend

 Precinct boundary

Precinct Plan  
Rockbank  
Gas Supply

Co-ordinate Datum  
MGA55

Scale A3  
1 : #####

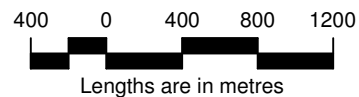

Date	3/4/2013	Sheet	1 of 1
Drawing No.	139029P00 GAS	Version	1
CAD Ref.	E:\JOBS\1009 ROCKBANK PSP\CAD FILES\ACAD		
Drawn By	ES	Checked By	SN
REV	AMENDMENT	APPROVED	DATE



445 Townsend Street  
PO Box 3400  
Albury NSW 2640  
T 61 2 6051 1300  
spiire.com.au



**Appendix 7**

Conceptual Cross Section

MRWA W-210 Underground Crossings

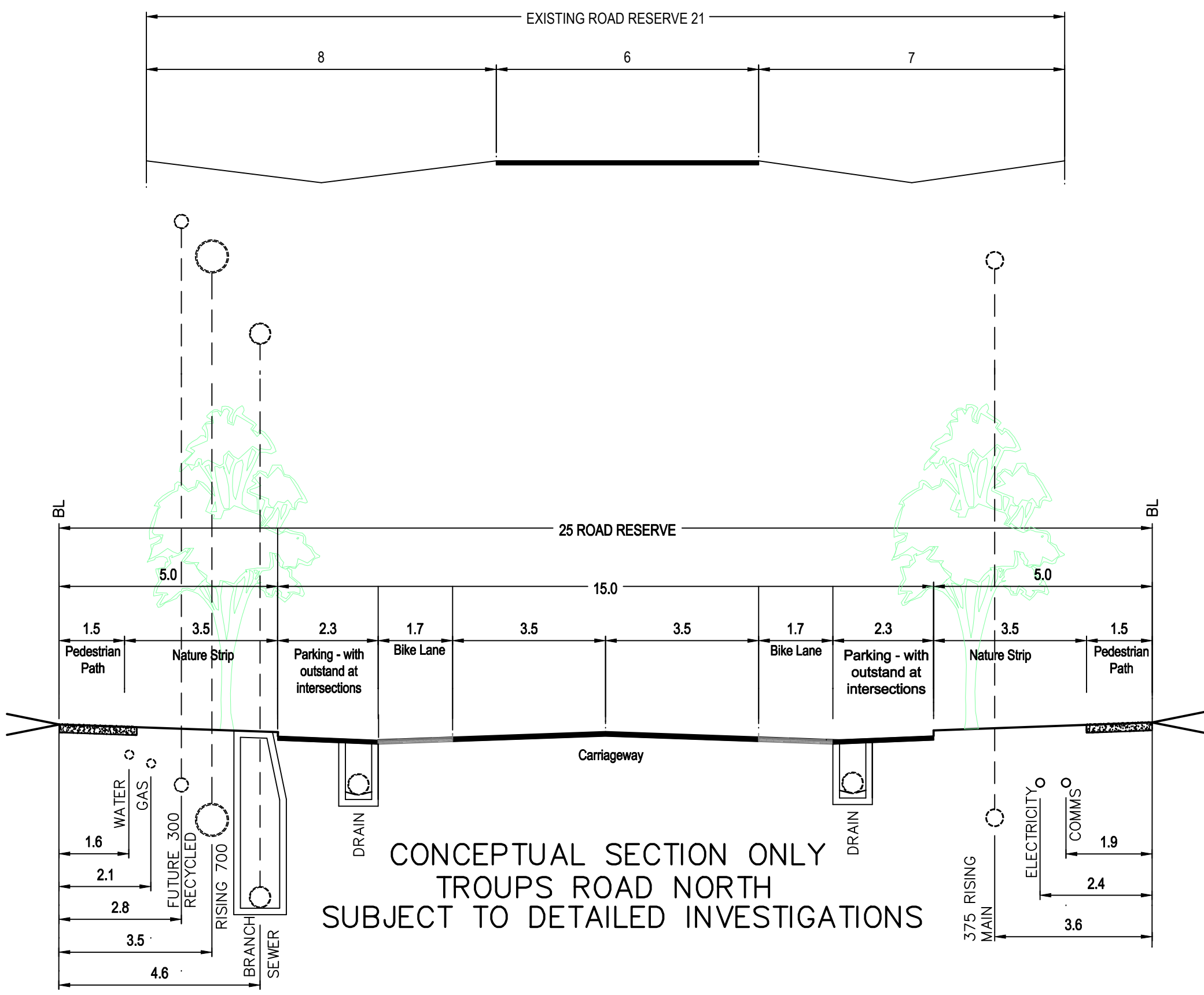
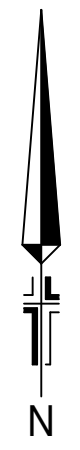

CONCEPTUAL SECTION ONLY  
 TROUPS ROAD NORTH  
 SUBJECT TO DETAILED INVESTIGATIONS

Precinct Plan Rockbank Connector Street - Residential	
Co-ordinate Datum MGA55	Scale A3 1 : 100

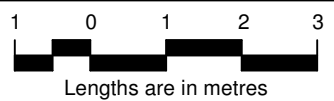

Date	18/10/2013	Sheet	1 of 1
Drawing No.	139029P00 TYPICAL	Version	1
CAD Ref.	E:\JOBS\1009 ROCKBANK PSPICAD FILES\ACAD		
Drawn By	ES	Checked By	SN
REV	AMENDMENT	APPROVED	DATE



445 Townsend Street  
 PO Box 3400  
 Albury NSW 2640  
 T 61 2 6051 1300  
 spiire.com.au

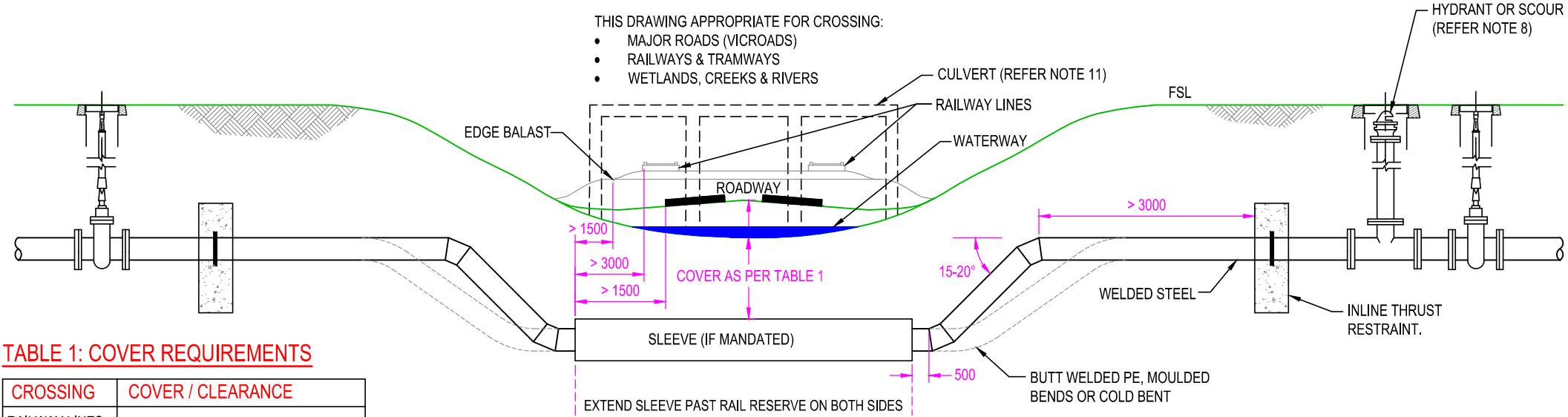

THIS DRAWING APPROPRIATE FOR CROSSING:

- MAJOR ROADS (VICROADS)
- RAILWAYS & TRAMWAYS
- WETLANDS, CREEKS & RIVERS

**TABLE 1: COVER REQUIREMENTS**

CROSSING	COVER / CLEARANCE
RAILWAY LINES	> 1600 BELOW RAIL LEVEL, > 600 BELOW FORMATION LEVEL (GROUND LEVEL IMMEDIATELY BELOW BALLAST), > 2000 BETWEEN RAIL LEVEL AND TOP OF TUNNELS
WATERWAYS	600
TRAMWAYS	1200 (TOP OF RAIL TO TOP OF PIPE)
MAJOR ROADS	1200

**DETAIL A: SECTION VIEW, MAJOR ROAD / RAILWAY / TRAM / WATERWAY CROSSING**

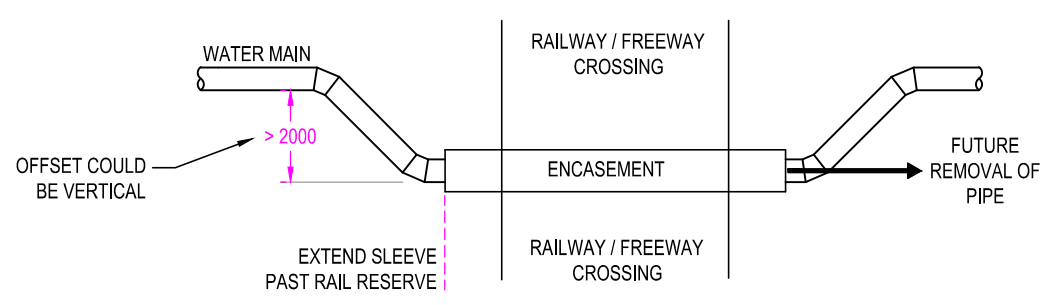

**DETAIL D: PLAN VIEW: RAILWAY / FREEWAY CROSSING**

SLEEVE REQUIRED TO ENABLE THE PIPE WITHIN TO BE REMOVED IN FUTURE

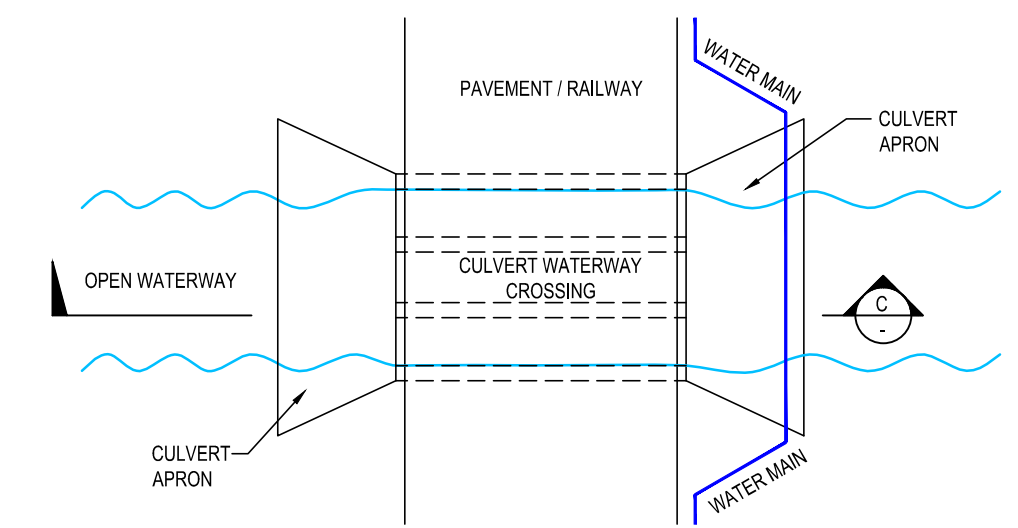

**DETAIL B: PLAN VIEW, WATERWAY CROSSING**

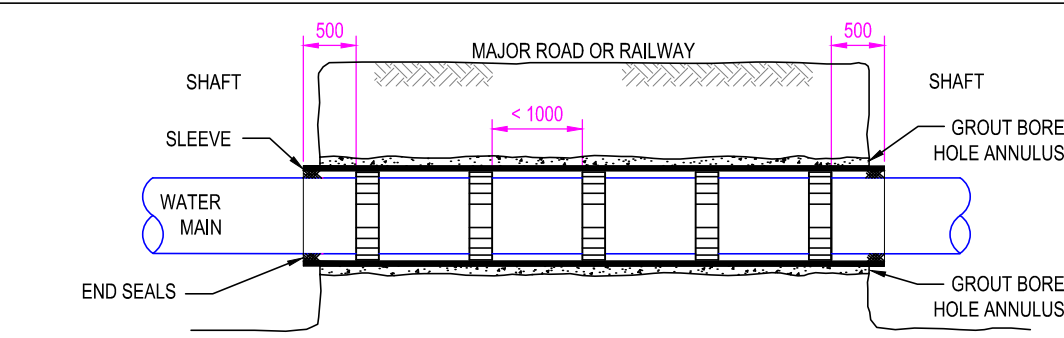

**DETAIL E: TYPICAL SLEEVE INSTALLATION**

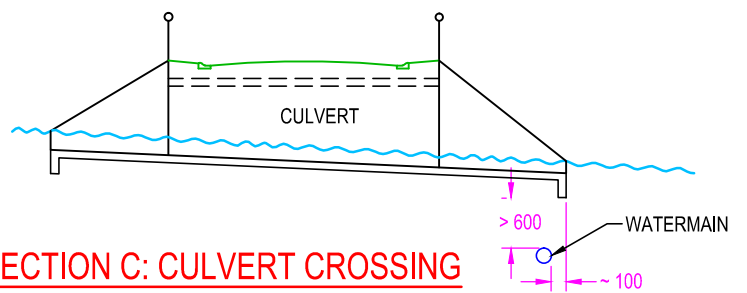

**SECTION C: CULVERT CROSSING**

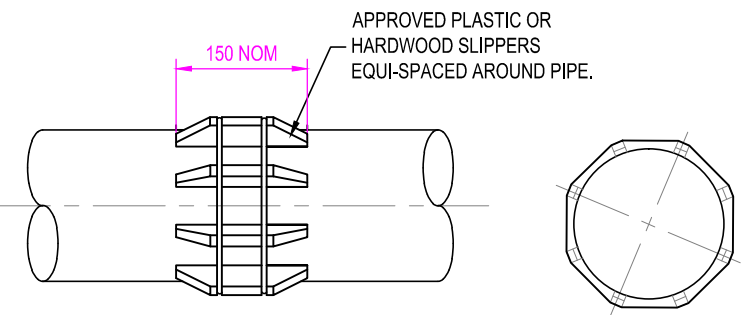

**DETAIL F: WATER MAIN SUPPORTS DETAIL**

**TABLE 2: OTHER CROSSING REQUIREMENTS**

CROSSING	REQUIREMENT
REGIONAL DRAINS (ie: MELBOURNE WATER)	AS PER DETAIL A, EXCEPT VALVES AT SIDES OF CROSSING & HYDRANT / SCOUR ARE NOT REQUIRED.
<ul style="list-style-type: none"> <li>LOCAL DRAINS (ie: COUNCIL),</li> <li>OTHER SERVICES,</li> <li>LOCAL STREETS.</li> </ul>	ANY APPROVED PIPELINE SYSTEM WHICH SATISFIES STRUCTURAL, CLEARANCE, COVER AND MRWA-W-212 REQUIREMENTS. JOINTS UNDER CROSSING TO BE MINIMISED, TYPICALLY ONLY 2 ALLOWED. THE JOINT(S) MUST BE HORIZONTALLY OFFSET FROM ANY PIPE OR SERVICE BEING CROSSED.

**MAJOR CROSSING NOTES:**

- ALL > DN250 MAJOR CROSSINGS TO BE CONSTRUCTED FROM FULLY WELDED MSCL OR BUTT WELDED PE. ON APPROVAL OF THE WA, ≤DN250 RRJ OR FLANGED MAINS MAY BE PERMITTED, PROVIDED THERE IS A MAXIMUM OF ONE SUCH JOINT UNDER THE STRUCTURE BEING CROSSED.
- LAND OWNER REQUIREMENTS (EG: VICRAIL) TAKE PRECEDENCE OVER THESE REQUIREMENTS.
- CONCRETE ENCASED PIPEWORK IS NOT PREFERRED.
- STEEL PIPE JOINTS TO BE EITHER PLAIN ENDS WITH WELDED COLLAR, BALL AND SOCKET OR SLIP IN WELDED JOINTS.
- ALL STEEL PIPEWORK IS TO BE FABRICATED AND PROTECTED AS PER MRWA-W-400 SERIES DRAWINGS, THE WATER AGENCY SPECIFICATION AND AS2832 (CATHODIC PROTECTION).
- ALL BEND LENGTHS AND ANGLES TO BE SPECIFIED IN THE DESIGN DRAWINGS.
- LOCATE A HYDRANT OR SCOUR (DEPENDING IN TOPOGRAPHY AND SIZE OF MAIN) ON THE LOW SIDE OF THE CROSSING (BETWEEN THE 2 DIVIDE VALVES) TO FACILITATE DEWATERING OF THE MAIN. HYDRANTS PREFERRED FOR SMALLER MAINS (<DN375) OR WHERE THE MAIN HAS A STEEP (> 1 IN 50) RISE ON BOTH SIDES OF THE CROSSING. WHERE A SCOUR IS TO BE USED, A HYDRANT OR AIR VALVE SHALL IN ADDITION BE LOCATED ON THE HIGH SIDE OF THE CROSSING TO FACILITATE AIR REMOVAL FROM THE MAIN.
- FOR SCOUR DESIGN, REFER TO DRAWING MRWA-W-308.
- MINIMUM COVER TO BE SPECIFIED WITHIN THE DESIGN DRAWING.
- WATER MAINS MAY CROSS WATERWAYS ABOVE CULVERTS, PROVIDED THAT MINIMUM COVER AND EMBEDMENT REQUIREMENTS ARE MET.

**SLEEVING NOTES:**

- SLEEVES AND END SEALS SHALL BE SPECIFICALLY DESIGNED BY A SENIOR CORROSION CONSULTANT AND DESIGNED FOR A SERVICE LIFE OF 100 YEARS.
- PIPES ONLY TO BE SLEEVED ONLY WHERE MANDATED BY THE LANDOWNER.
- SLEEVE FOR CATHODICALLY PROTECTED MSCL MAIN MUST BE CONDUCTIVE (ie: STEEL OR CONCRETE) AND UNCONNECTED TO THE MSCL MAIN.
- SLEEVE FOR OTHER MAINS TO BE GRP, BUTT WELDED PE OR CATHODICALLY PROTECTED WELDED STEEL, OF A PN RATING APPROPRIATE TO THE GROUND CONDITIONS.
- WATER MAIN SUPPORTS (AS SHOWN IN DETAIL F) MUST BE FIRMLY FASTENED AND NOT MOVE OR DAMAGE THE WATER MAIN ONCE ATTACHED.
- ONCE A MSCL WATER MAIN IS INSERTED INTO THE SLEEVE, A COATING INTEGRITY CHECK OF THE WATER MAIN MUST BE COMPLETED VIA A CAMERA INSPECTION. FOOTAGE MUST BE PROVIDED TO THE WATER AGENCY AND ANY DAMAGE REPORTED.
- WHEN BORE HOLE ANNULUS > 50, GROUT AS PER WSA03 MRWA EDITION. SLEEVE TO BE GROUTED IN PLACE WITH A FLOWABLE GROUT, eg: LIQUAFILL OR BENTONITE.
- ENSURE GROUTING PRESSURES DO NOT EXCEED THE BUCKLING CAPABILITY OF THE PIPE WHEN EMPTY.
- WATER MAINS TO BE SUPPORTED USING SLIPPERS WITHIN ENCASEMENT. SLIPPERS MAYBE OMITTED IN THE CASE OF WELDED PE MAINS WITH APPROVAL OF THE WA.

DESIGNED:	R. JAGGER	DATE:	15/06/2011
DRAWN:	D. TOLENTINO	DATE:	15/06/2011
CHECKED:	NAME	DATE	APPROVED: NAME
	☒ CWW	C. RIVETTE	23/03/12
	☒ SEWL	C.PAXMAN	23/03/12
	☒ YVW	K.DAWSON	23/03/12
			☒ CWW
			R.CARRUTHERS
			23/03/12
			☒ SEWL
			G.REYNOLDS
			23/03/12
			☒ YVW
			A.COSHAM
			23/03/12

MELBOURNE RETAIL WATER AGENCIES

**MRWA WATER SUPPLY STANDARD DRAWINGS**

**UNDERGROUND CROSSINGS**

**NOT TO SCALE**

**MRWA-W-210**

ISSUED 2012 | VERSION 2



GHD

Level 8

180 Lonsdale Street

T: 61 3 8687 8000 F: 61 3 8687 8111 E: melmail@ghd.com

© GHD 2018

This document is and shall remain the property of GHD. The document may only be used for the purpose for which it was commissioned and in accordance with the Terms of Engagement for the commission. Unauthorised use of this document in any form whatsoever is prohibited.

3135577-

92293/<https://projects.ghd.com/oc/Victoria/rockbanktowncentre/Delivery/Documents/3135577> - REP - Rockbank Town Centre Utility Servicing Review - 24 October 2017.docx

Document Status

Revision	Author	Reviewer		Approved for Issue		
		Name	Signature	Name	Signature	Date
0	M.Snaize	M.George	M.George*	M.George	M.George*	25/01/18

\*Denotes signature on original

[www.ghd.com](http://www.ghd.com)

